

Aluminum Electrolytic Capacitors

Products Catalog

Radial Lead Type



Aluminum Electrolytic Capacitors (Radial lead type) INDEX

Item		Page
Guideline		1
Selection guide	Diagram	8
	Explanation of part numbers	9
	Lead taping radial lead type	10
	Packaging specifications	12
Series	FR-A : 105 °C 3000 to 5000 h	13
	FS-A : 105 °C 5000 to 10000 h	18
	FP-A : 105 °C 4000 to 5000 h	23
	ED-A : 105 °C 8000 to 10000 h	25
	GA-A : 105 °C 1000 h	28
	KA-A : 85 °C 1000 h	30
	KA-A (Bi-polar) : 85 °C 1000 h	32
	KS-A : 85 °C 1000 h	34
	KS-A (Bi-polar) : 85 °C 1000 h	36
This Series is no longer available for purchase in the country of Japan.		
Series	FC-A : 105 °C 1000 to 5000 h	38
	FK-A : 105 °C 3000 to 5000 h	48
	FM-A : 105 °C 2000 to 7000 h	53
	EB-A : 105 °C 5000 to 10000 h	57
	EE-A : 105 °C 8000 to 10000 h	60
	TA-A : 125 °C 2000 h	64
	TP-A : 125 °C 2000 to 5000 h	67
	HD-A : 105 °C 1000 to 2000 h	69
	NHG-A : 105 °C 1000 to 2000 h	72
	GA-A (Bi-polar) : 105 °C 1000 to 2000 h	77
	M-A : 85 °C 2000 h	79
	SU-A (Bi-polar) : 85 °C 2000 h	84

Guidelines and precautions regarding the technical information and use of our products described in this online catalog.

- If you want to use our products described in this online catalog for applications requiring special qualities or reliability, or for applications where the failure or malfunction of the products may directly jeopardize human life or potentially cause personal injury (e.g. aircraft and aerospace equipment, traffic and transportation equipment, combustion equipment, medical equipment, accident prevention, anti-crime equipment, and/or safety equipment), it is necessary to verify whether the specifications of our products fit to such applications. Please ensure that you will ask and check with our inquiry desk as to whether the specifications of our products fit to such applications use before you use our products.
- The quality and performance of our products as described in this online catalog only apply to our products when used in isolation. Therefore, please ensure you evaluate and verify our products under the specific circumstances in which our products are assembled in your own products and in which our products will actually be used.
- If you use our products in equipment that requires a high degree of reliability, regardless of the application, it is recommended that you set up protection circuits and redundancy circuits in order to ensure safety of your equipment.
- The products and product specifications described in this online catalog are subject to change for improvement without prior notice. Therefore, please be sure to request and confirm the latest product specifications which explain the specifications of our products in detail, before you finalize the design of your applications, purchase, or use our products.
- The technical information in this online catalog provides examples of our products' typical operations and application circuits. We do not guarantee the non-infringement of third party's intellectual property rights and we do not grant any license, right, or interest in our intellectual property.
- If any of our products, product specifications and/or technical information in this online catalog is to be exported or provided to non-residents, the laws and regulations of the exporting country, especially with regard to security and export control, shall be observed.

<Regarding the Certificate of Compliance with the EU RoHS Directive/REACH Regulations>

- The switchover date for compliance with the RoHS Directive/REACH Regulations varies depending on the part number or series of our products.
- When you use the inventory of our products for which it is unclear whether those products are compliant with the RoHS Directive/REACH Regulation, please select "Sales Inquiry" in the website inquiry form and contact us.

We do not take any responsibility for the use of our products outside the scope of the specifications, descriptions, guidelines and precautions described in this online catalog.

Notices

■ Applicable laws and regulations

- This product complies with the RoHS Directive (Restriction of the use of certain hazardous substances in electrical and electronic equipment (DIRECTIVE 2011/65/EU and (EU)2015/863)).
- No Ozone Depleting Chemicals(ODC's), controlled under the Montreal Protocol Agreement, are used in producing this product.
We do not use PBBs or PBDEs as brominated flame retardants.
- Export procedure which followed export related regulations, such as foreign exchange and a foreign trade method, on the occasion of export of this product.
- These products are not dangerous goods on the transportation as identified by UN(United Nations) numbers or UN classification.

■ Limited applications

- This capacitor is designed to be used for electronics circuits such as audio/visual equipment, home appliances, computers and other office equipment, optical equipment, measuring equipment.
- High reliability and safety are required [be / a possibility that incorrect operation of this product may do harm to a human life or property] more. When use is considered by the use, the delivery specifications which suited the use separately need to be exchanged.

■ Intellectual property rights and licenses

- The technical information in this specification provides examples of our products' typical operations and application circuits. We do not guarantee the non-infringement of third party's intellectual property rights and we do not grant any license, right, or interest in our intellectual property.

Items to be observed

■ For specification

- This specification guarantees the quality and performance of the product as individual components. The durability differs depending on the environment and the conditions of usage. Before use, check and evaluate their compatibility with actual conditions when installed in the products. When safety requirements cannot be satisfied in your technical examination, inform us immediately.
- Do not use the products beyond the specifications described in this document.

■ Upon application to products where safety is regarded as important

Install the following systems for a failsafe design to ensure safety if these products are to be used in equipment where a defect in these products may cause the loss of human life or other signification damage, such as damage to vehicles (automobile, train, vessel), traffic lights, medical equipment, aerospace equipment, electric heating appliances, combustion/ gas equipment, rotating rotating equipment, and disaster/crime prevention equipment.

- (1) The system is equipped with a protection circuit and protection device.
- (2) The system is equipped with a redundant circuit or other system to prevent an unsafe status in the event of a single fault.

■ Conditions of use

- Before using the products, carefully check the effects on their quality and performance, and determined whether or not they can be used. These products are designed and manufactured for general-purpose and standard use in general electronic equipment. These products are not intended for use in the following special conditions.
 - (1) In liquid, such as Water, Oil, Chemicals, or Organic solvent.
 - (2) In direct sunlight, outdoors, or in dust.
 - (3) In vapor, such as dew condensation water of resistive element, or water leakage, salty air, or air with a high concentration corrosive gas, such as Cl₂, H₂S, NH₃, SO₂, or NO_x.
 - (4) In an environment where strong static electricity or electromagnetic waves exist.
 - (5) Mounting or placing heat-generating components or inflammables, such as vinyl-coated wires, near these products.
 - (6) Sealing or coating of these products or a printed circuit board on which these products are mounted, with resin and other material.
 - (7) Using solvent, water or water-soluble cleaner for flux cleaning agent after soldering. (In particular, when using water or a water-soluble cleaning agent, be careful not to leave water residues)
 - (8) Using in the atmosphere where strays acid or alkaline.
 - (9) Using in the atmosphere where there are excessive vibration and shock.
- Please arrange circuit design for preventing impulse or transitional voltage.
Do not apply voltage, which exceeds the full rated voltage when the capacitors receive impulse voltage, instantaneous high voltage, high pulse voltage etc.
- Our products there is a product are using an electrolyte solution. Therefore, misuse can result in rapid deterioration of characteristics and functions of each product. Electrolyte leakage damages printed circuit and affects performance, characteristics, and functions of customer system.

⚠ Application guidelines (Radial lead Type)

1. Circuit design

1.1 Operating temperature and frequency

Electrical characteristics of the capacitor are likely to change due to variation in temperature and/or frequency. Circuit designers should take these changes into consideration.

(1) Effects of operating temperature on electrical parameters

At higher temperatures : leakage current and capacitance increase while equivalent series resistance (ESR) decreases.

At lower temperatures : leakage current and capacitance decrease while equivalent series resistance (ESR) increases.

(2) Effects of frequency on electrical parameters

At higher frequencies : capacitance and impedance decrease while tan d increases.

At lower frequencies : heat generated by ripple current will rise due to an increase in equivalent series resistance (ESR).

1.2 Operating temperature and life expectancy

(1) Expected life is affected by operating temperature. Generally, each 10 °C reduction in temperature will double the expected life. Use capacitors at the lowest possible temperature below the upper category temperature.

(2) If operating temperatures exceed the upper category limit, rapid deterioration of electrical parameter will occur and irreversible damage will result.

Check for the maximum capacitor operating temperatures including ambient temperature, internal capacitor temperature rise due to ripple current, and the effects of radiated heat from power transistors, IC's or resistors.

Avoid placing components, which could conduct heat to the capacitor from the back side of the circuit board.

(3) The formula for calculating expected life at lower operating temperatures is as follows ;

$$L_2 = L_1 \times 2^{\frac{T_1 - T_2}{10}}$$

L₁ : Guaranteed life (h) at temperature, T₁ °C

L₂ : Expected life (h) at temperature, T₂ °C

T₁ : Upper category temperature + temperature rise due to rated ripple current (°C)

T₂ : Actual operating temperature, ambient temperature + temperature rise due to ripple current (°C)

(4) Using the capacitor beyond the estimated lifetime will result in short circuit, electrolyte leak, vent open, and large deterioration of characteristics. The lifetime cannot go above 15 years due to aging of sealing rubber.

1.3 Common application conditions to avoid

The following misapplication load conditions will cause rapid deterioration of a capacitor's electrical parameters. In addition, rapid heating and gas generation within the capacitor can occur, causing the pressure relief vent to operate and resultant leakage of electrolyte. Under extreme conditions, explosion and fire ignition could result. The leaked electrolyte is combustible and electrically conductive.

(1) Reverse voltage

DC capacitors have polarity. Therefore, please do not apply the reverse voltage. Verify correct polarity before insertion.

For circuits with changing or uncertain polarity, use DC bipolar capacitors. DC bipolar capacitors are not suitable for use in AC circuits.

(2) Charge / Discharge applications

Standard capacitors are not suitable for use in repeating charge/discharge applications. For charge/discharge applications, consult us with your actual application condition.

For rush current, please do not exceed 100 A.

(3) ON-OFF circuit

Do not use capacitors in circuit where ON-OFF switching is repeated more than 10000 times/per day.

In case of applying to the these ON-OFF circuit, consult with us about circuit condition and so on.

(4) Over voltage

Do not apply voltages exceeding the maximum specified rated voltage. Voltages up to the surge voltage rating are acceptable for short periods of time.

Ensure that the sum of the DC voltage and the superimposed AC ripple voltage does not exceed the rated voltage.

(5) Ripple current

Do not apply ripple currents exceeding the maximum specified value. For high ripple current applications, use a capacitor designed for high ripple currents. In addition, consult us if the applied ripple current is to be higher than the maximum specified value. Ensure that rated ripple currents that superimposed on low DC bias voltages do not cause reverse voltage conditions.

Even if it is within a rated ripple current, in case the practical use is over the pre described endurance lifetime, it causes the increase of deterioration of ESR characteristic and the internal generation heat by ripple current. Due to this, there is some possibility of vent open, bulging of sleeve and rubber, electrolyte leakage, and short circuit, explosion and ignition in the worst case.

1.4 Using two or more capacitors in parallel

(1) Capacitors connected in parallel

The circuit resistance can closely approximate the series resistance of the capacitor, causing an imbalance of ripple current loads within the capacitors. Careful wiring methods can minimize the possible application of an excessive ripple current to a capacitor.

(2) Capacitors connected in series

Differences in normal DC leakage current among capacitors can cause voltage imbalances.

The use of voltage divider shunt resistors with consideration to leakage currents can prevent capacitor voltage imbalances.

NOTE : Please do not use in the series in the case of conductive polymer hybrid aluminum electrolytic capacitor.

1.5 Capacitor mounting considerations

(1) Double-sided circuit boards

Avoid wiring pattern runs, which pass between the mounted capacitor and the circuit board.

When dipping into a solder bath, an excess solder may deposit under the capacitor by capillary action, causing short circuit between anode and cathode terminals.

(2) Circuit Board Hole Positioning

The vinyl sleeve of the capacitor can be damaged if solder passes through a lead hole into the subsequently processed parts.

Special care when locating hole positions in proximity to capacitors is recommended.

(3) Circuit Board Hole Spacing

The spacing of circuit board holes should match the lead wire spacing of capacitors within the specified tolerances. Incorrect spacing can cause an excessive lead wire stress during the insertion process.

This may result in premature capacitor failure due to the short or open circuit, increased leakage current, or electrolyte leakage.

(4) Clearance for case mounted pressure relief

Capacitors with case mounted pressure relief require sufficient clearance to allow for proper pressure relief operation.

The minimum clearance are dependent on capacitor diameters as follows.

(\varnothing 10 mm to \varnothing 16 mm : 2 mm minimum, \varnothing 18 mm : 3 mm minimum)

(5) Wiring near the pressure relief

Avoid locating high voltage or high current wiring or circuit board paths above the pressure relief.

Flammable, high temperature gas that exceeds 100 °C may be released which could dissolve the wire insulation and ignite.

(6) Circuit board patterns under the capacitor

Avoid circuit board runs under the capacitor, as an electrical short can occur due to an electrolyte leakage.

(7) Please note the resonant after product implementation

The vicinity of the resonant point will take a heavy load on the capacitor.

Capacitors can cause rapid change in characteristics and dropout by this load.

1.6 Electrical isolation of the capacitor

Completely isolate the capacitor as follows.

Between the cathode and the case and between the anode terminal and other circuit paths.

1.7 Capacitor Sleeve

The vinyl sleeve or laminate coating is intended for marking and identification purposes and is not meant to electrically insulate the capacitor.

The sleeve may split or crack if immersed into solvents such as toluene or xylene and then subsequently exposed to high temperatures.

2. Capacitor handling techniques

2.1 Considerations before using

- (1) Capacitors have a finite life. Do not reuse or recycle capacitors from used equipment.
- (2) Transient recovery voltage may be generated in the capacitor due to dielectric absorption.
If required, this voltage can be discharged with a resistor with a value of about 1 k Ω .
- (3) Capacitors stored for a long period of time may exhibit an increase in leakage current.
This can be corrected by gradually applying rated voltage in series with a resistor of approximately 1 k Ω .
- (4) If capacitors are dropped, they can be damaged mechanically or electrically. Avoid using dropped capacitors.
- (5) Dented or crushed capacitors should not be used.
The seal integrity can be damaged and loss of electrolyte/ shortened life can result.

2.2 Capacitor insertion

- (1) Verify the correct capacitance and rated voltage of the capacitor.
- (2) Verify the correct polarity of the capacitor before insertion.
- (3) Verify the correct terminal dimension and land pattern size before mount to avoid stress on the terminals.
- (4) Ensure that the lead clinching operation done by auto insertion equipments does not stress the capacitor leads where they enter the seal of the capacitor.

2.3 Flow Soldering

- (1) Do not immerse the capacitor body into the solder bath as excessive internal pressure could result.
- (2) Apply proper soldering conditions (temperature, time, etc.). Do not exceed the specified limits.
- (3) Do not allow other parts or components to touch the capacitor during soldering.
- (4) Radial lead type capacitors are not allowed for the reflow soldering.

2.4 Manual soldering

- (1) Apply soldering conditions (temperature and time) based on the specification, or do not exceed temperature of 350 °C for 3 seconds or less.
- (2) If lead wires must be modified to meet terminal board hole spacing, avoid stress on the lead wire where it enters the capacitor seal.
- (3) If a soldered capacitor must be removed and reinserted, avoid excessive stress on the capacitor leads.
- (4) Avoid physical contacts between the tip of the soldering iron and capacitors to prevent melting of the vinyl sleeve.

2.5 Other Soldering Considerations

Rapid temperature rise during the preheat operation and resin bonding operation can cause cracking of the capacitor's vinyl sleeve.

For heat curing, do not exceed 150 °C for the maximum time of 2 minutes.

2.6 Capacitor handling after soldering

- (1) Avoid moving the capacitor after soldering to prevent excessive stress on the lead wires where they enter the seal. The capacitor may break from element portion due to a torque at outer rim, causing a large stress to terminals.
- (2) Do not use the capacitor as a handle when moving the circuit board assembly. The total weight of the board would apply to element portion through terminals, and the capacitor may break.
- (3) Avoid striking the capacitor after assembly to prevent failure due to excessive shock. The capacitor may break due to excessive shock or load above specified range.

2.7 Circuit board cleaning

- (1) Circuit boards can be immersed or ultrasonically cleaned using suitable cleaning solvents for up to 5 minutes and up to 60 °C maximum temperatures. The boards should be thoroughly rinsed and dried. The use of ozone depleting cleaning agents is not recommended for the purpose of protecting our environment.

【Target solvent】

Pine Alpha ST-100S, Aqua Cleaner 210SEP, Clean-thru 750H / 750L / 710M, Sunelec B-12, Sunelec B-12, Cold Cleaner P3-375, Techno Cleaner 219, DK Be-clear CW-5790, Telpene Cleaner EC-7R, Technocare FRW-17 / FRW-1 / FRV-1

- (2) Avoid using the following solvent groups unless specifically allowed in the specification ;
 - (a) Halogenated cleaning solvents : except for solvent resistant capacitor types, halogenated solvents can permeate the seal and cause internal capacitor corrosion and failure.
For solvent resistant capacitors, carefully follow the temperature and time requirements based on the specification. 1,1,1-trichloroethane should never be used on any aluminum electrolytic capacitor.
 - (b) Alkaline solvents : could react and dissolve the aluminum case.
 - (c) Petroleum based solvents : deterioration of the rubber seal could result.
 - (d) Xylene : deterioration of the rubber seal could result.
 - (e) Acetone : removal of the ink markings on the vinyl sleeve could result.
 - (3) A thorough drying after cleaning is required to remove residual cleaning solvents that may be trapped between the capacitor and the circuit board. Avoid drying temperatures, which exceed the upper category temperature of the capacitor.
 - (4) Monitor the contamination levels of the cleaning solvents during use in terms of electrical conductivity, pH, specific gravity, or water content.
Chlorine levels can rise with contamination and adversely affect the performance of the capacitor.
Control the flux density in the cleaning agent to be less than 2 mass%.
 - (5) Depending on the cleaning method, the marking on a capacitor may be erased or blurred.
- ※ Please consult us if you are not certain about acceptable cleaning solvents or cleaning methods.

2.8 Mounting adhesives and coating agents

When using mounting adhesives or coating agents to control humidity, avoid using materials containing halogenated solvents.

Also, avoid the use of chloroprene based polymers.

Harden on dry adhesive or coating agents well lest the solvent should be left.

After applying adhesives or coatings, dry thoroughly to prevent residual solvents from being trapped between the capacitor and the circuit board.

2.9 Fumigation

In exporting electronic appliances with aluminum electrolytic capacitors, in some cases fumigation treatment using such halogen compound as methyl bromide is conducted for wooden boxes.

If such boxes are not dried well, the halogen left in the box is dispersed while transported and enters in the capacitors inside.

This possibly causes electrical corrosion of the capacitors. Therefore, after performing fumigation and drying make sure that no halogen is left.

Don't perform fumigation treatment to the whole electronic appliances packed in a box.

Leave more than 1/3 of the sealing portion open, and do not cover that portion with any adhesives or coating.

2.10 Flux

If you use a halogen type (Chlorine type, Bromine type, etc.) high-activity flux, please use it after confirmation in advance, as it may have an impact on performance and reliability of this product due to the residue of the flux.

3. Precautions for using capacitors

3.1 Environmental conditions

Capacitors should not be stored or used in the following environments.

- (1) Exposure to temperatures above the upper category or below the lower category temperature of the capacitor.
- (2) Direct contact with water, salt water, or oil.
- (3) High humidity conditions where water could condense on the capacitor.
- (4) Exposure to toxic gases such as hydrogen sulfide, sulfuric acid, nitric acid, chlorine, chlorine compound, bromine, bromine compound or ammonia.
- (5) Exposure to ozone, radiation, or ultraviolet rays.
- (6) Vibration and shock conditions exceeding specified requirements.

Even within the specified requirements, a large vibration acceleration may be applied due to resonance, so be sure to evaluate and confirm with the actual product.

3.2 Electrical precautions

- (1) Avoid touching the terminals of a capacitor as a possible electric shock could result. The exposed aluminum case is not insulated and could also cause electric shock if touched.
- (2) Avoid short circuiting the area between the capacitor terminals with conductive materials including liquids such as acids or alkaline solutions.
- (3) A low-molecular-weight-shiroxane which is included in a silicon material shall causes abnormal electrical characteristics.

4. Emergency procedures

- (1) If the pressure relief of the capacitor operates, immediately turn off the equipment and disconnect from the power source.
This will minimize an additional damage caused by the vaporizing electrolyte.
- (2) Avoid contact with the escaping electrolyte gas, which can exceed 100 °C temperatures.
If electrolyte or gas enters the eye, immediately flush the eye with large amounts of water.
If electrolyte or gas is ingested by mouth, gargle with water.
If electrolyte contacts the skin, wash with soap and water.

5. Long term storage

- (1) Leakage current of a capacitor increases with long storage times. The aluminum oxide film deteriorates as a function of temperature and time.
If used without reconditioning, an abnormally high current will be required to restore the oxide film.
This surge current could cause the circuit or the capacitor to fail.
Expiration date is 42 months from outgoing inspection date.
However, expiration date for series which are not listed below is 12 months from outgoing inspection date.

Series	Expiration date
FC, FK, FP, HD, TA, TP	42 months from outgoing inspection date

For storage condition, keep room temperature (5 °C to 35 °C) and humidity (45 % to 85 %) where direct sunshine doesn't reach.

- (2) Environmental Conditions
Do not store under condition outside the area described in the specification, and also under conditions listed below.
 - (a) Exposure to temperatures above the upper category or below the lower category temperature of the capacitor.
 - (b) Direct contact with water, salt water, or oil.
 - (c) High humidity conditions where water could condense on the capacitor.
 - (d) Exposure to toxic gases such as hydrogen sulfide, sulfuric acid, nitric acid, chlorine, Chlorine compound, Bromine, Bromine compound or ammonia.
 - (e) Exposure to ozone, radiation, or ultraviolet rays.
 - (f) Vibration and shock conditions exceeding specified requirements.

6. Capacitor disposal

When disposing capacitors, use one of the following methods.

- (1) Incinerate after crushing the capacitor or puncturing the can wall (to prevent explosion due to internal pressure rise).
- (2) Dispose as solid waste.

NOTE : Local laws may have specific disposal requirements which must be followed.

The precautions in using aluminum electrolytic capacitors follow the "Safety application guide for the use in fixed aluminum electrolytic capacitors for electronic equipment", RCR-2367D issued by JEITA in October 2017.

Please refer to the above application guide for details.

■ AEC-Q200 compliant

The products are tested based on all or part of the test conditions and methods defined in AEC-Q200. Please consult with Panasonic for the details of the product specification and specific evaluation test results, etc., and please review and approve Panasonic's product specification before ordering.

Diagram

 This Series is no longer available for purchase in the country of Japan.

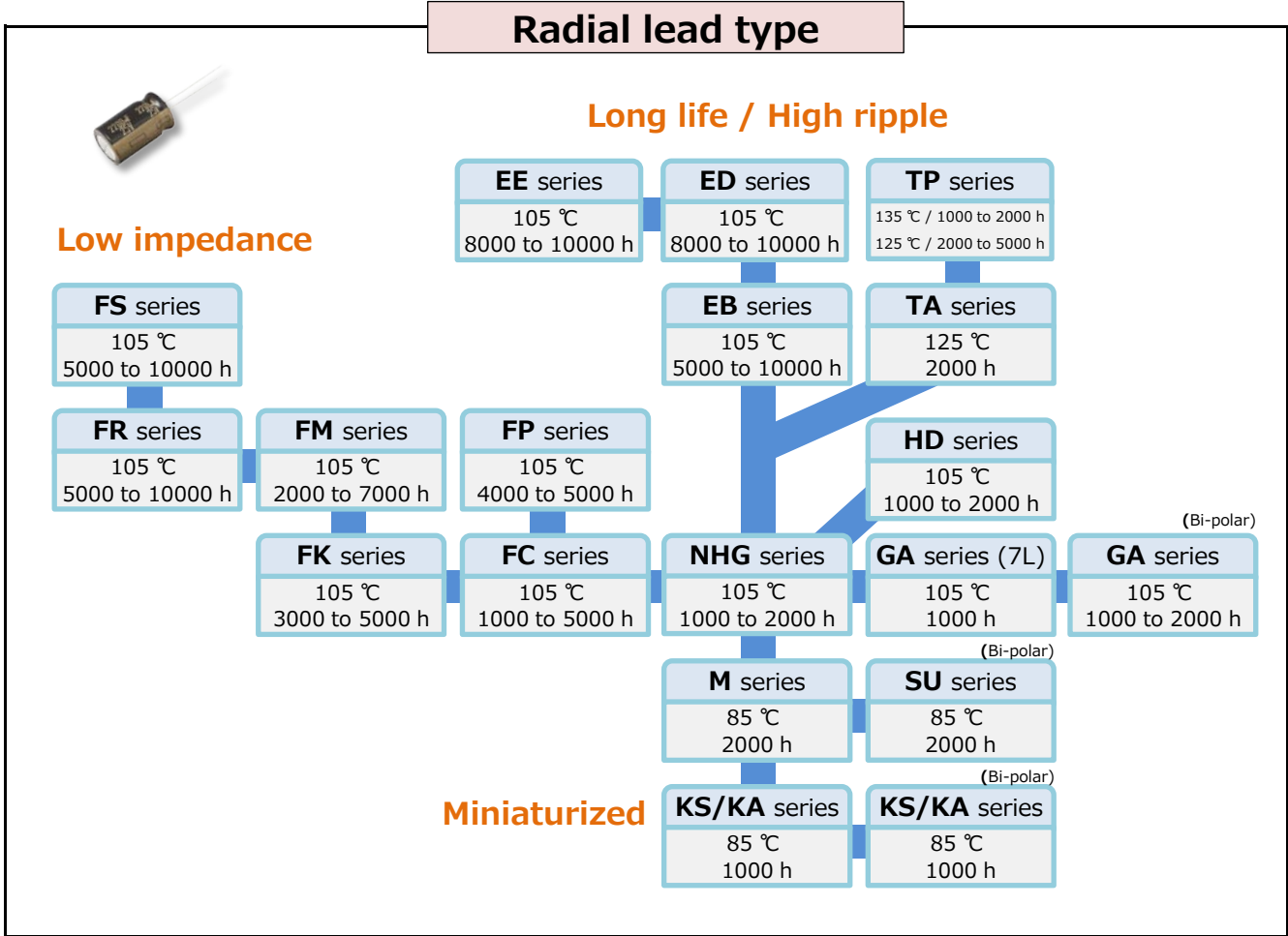

Explanation of part numbers

Part number system

◇ **Type 1 (Series : FC, FK, FM, FR, FS, FP, EB, ED, EE, TA, TP, HD, GA)**

EEU Product classification 3 figures	FC Series code 2 figures	0J Voltage code 2 figures	272 Capacitance code 3 figures	□+B Suffix+Taping of forming of terminal code 0 to 2 figures
---	---------------------------------------	--	---	---

Series	Code	R.voltage (V)	Code	Cap. (μF)	Code	Cap. (μF)	Code
FC (105 °C 1000 h to 5000 h)	FC	6.3	0J	1.5	1R5	390	391
FK (105 °C 4000 h to 5000 h)	FK	10	1A	2.2	2R2	470	471
FM (105 °C 4000 h to 7000 h)	FM	16	1C	3.3	3R3	510	511
FR (105 °C 5000 h to 10000 h)	FR	25	1E	4.7	4R7	560	561
FP (105 °C 4000 h to 5000 h)	FP	35	1V	5.6	5R6	680	681
EB (105 °C 5000 h to 10000 h)	EB	50	1H	6.8	6R8	820	821
ED (105 °C 8000 h to 10000 h)	ED	63	1J	10	100	1000	102
EE (105 °C 8000 h to 10000 h)	EE	100	2A	12	120	1200	122
TA (125 °C 2000 h)	TA	160	2C	15	150	1500	152
TP (125 °C 3000 h to 5000 h)	TP	200	2D	18	180	1600	162
HD (105 °C 2000 h)	HD	250	2E	22	220	1800	182
GA (105 °C 1000 h)	GA	350	2V	27	270	2000	202
		400	2G	33	330	2200	222
		450	2W	39	390	2700	272
				47	470	3300	332
				56	560	3900	392
				68	680	4700	472
				82	820	5100	512
				100	101	5600	562
				120	121	6800	682
				150	151	8200	822
				180	181	10000	103
				220	221	12000	123
				270	271	15000	153
				330	331	22000	223

Taping of forming of terminal code	
* Blank	: Straight
* E	: Lead forming
* B	: Taping (Pitch 5.0, 7.5 mm)
* H	: Taping (Pitch 2.5 mm)

◇ **Type 2 (Series : NHG, GA-Bipolar, M)**

ECA Product classification 3 figures	0J Voltage code 2 figures	HG Series code 1 to 2 figures	101 Capacitance code 3 figures	□+B Suffix+Taping of forming of terminal code 0 to 3 figures
---	--	--	---	---

R.voltage (V)	Code	Series	Code	Cap. (μF)	Code	Cap. (μF)	Code
6.3	0J	NHG (105°C 1000 h to 2000 h)	HG	1.5	1R5	330	331
10	1A	GA-Bipolar (105°C 1000 h to 2000 h)	EN	2.2	2R2	470	471
16	1C	M (85°C 2000 h)	M	3.3	3R3	1000	102
25	1E			4.7	4R7	2200	222
35	1V			10	100	3300	332
50	1H			22	220	4700	472
63	1J			33	330	6800	682
100	2A			47	470	12000	123
160	2C			100	101	15000	153
200	2D			220	221	22000	223
250	2E						
350	2V						
400	2G						
450	2W						

Taping of forming of terminal code	
* Blank	: Straight
* E	: Lead forming
* B	: Taping (Pitch 5.0, 7.5 mm)
* i	: Taping (Pitch 2.5 mm)

◇ **Type 3 (Series : KA, KA-Bipolar, KS, KS-Bipolar, SU-Bipolar)**

ECEA Product classification 4 figures	0J Voltage code 2 figures	N Series code 1 to 2 figures	472 Capacitance code 3 figures	□+B Suffix+Taping of forming of terminal code 0 to 1 figures
--	--	---	---	---

R.voltage (V)	Code	Series	Code	Cap. (μF)	Code	Cap. (μF)	Code
4	0D	KA (85°C 1000 h)	KA	2.2	2R2	220	221
6.3	0J	KA-Bipolar (85°C 1000 h)	KN	3.3	3R3	330	331
10	1A	KS (85°C 1000 h)	KS	4.7	4R7	470	471
16	1C	KS-Bipolar (85°C 1000 h)	SN	10	100	1000	102
25	1E	SU-Bipolar (85°C 2000 h)	N	22	220	2200	222
35	1V			33	330	3300	332
50	1H			47	470	4700	472
				100	101	6800	682

Taping of forming of terminal code	
* Blank	: Straight
* E	: Lead forming
* B	: Taping (Pitch 5.0, 7.5 mm)
* i	: Taping (Pitch 2.5 mm)

Lead taping radial lead type

● Dimensions

Case size(mm) $\phi D \times L$	Lead space		
	2.5 mm	5.0 mm	7.5 mm
	Figure	Figure	Figure
4 × 5, 7	B	A	—
5 × 5, 7	B	A	—
6.3 × 5, 7	C	A	—
8 × 5, 7	C	E	—
5 × 11	C	D	—
6.3 × 11.2, 15	C	D	—

Case size(mm) $\phi D \times L$	Lead space		
	2.5 mm	5.0 mm	7.5 mm
	Figure	Figure	Figure
8 × 11.5, 15, 20	—	E	—
10 × 12.5, 16, 20, 25	—	F	—
12.5 × 15, 20, 25	—	G	—
16 × 15, 20, 25	—	—	H
18 × 15, 20, 25	—	—	H

Figure A (Lead space : 5.0 mm / $\phi D \times L$: $\phi 4 \times 5, 7, \phi 5 \times 5, 7, \phi 6.3 \times 5, 7$)

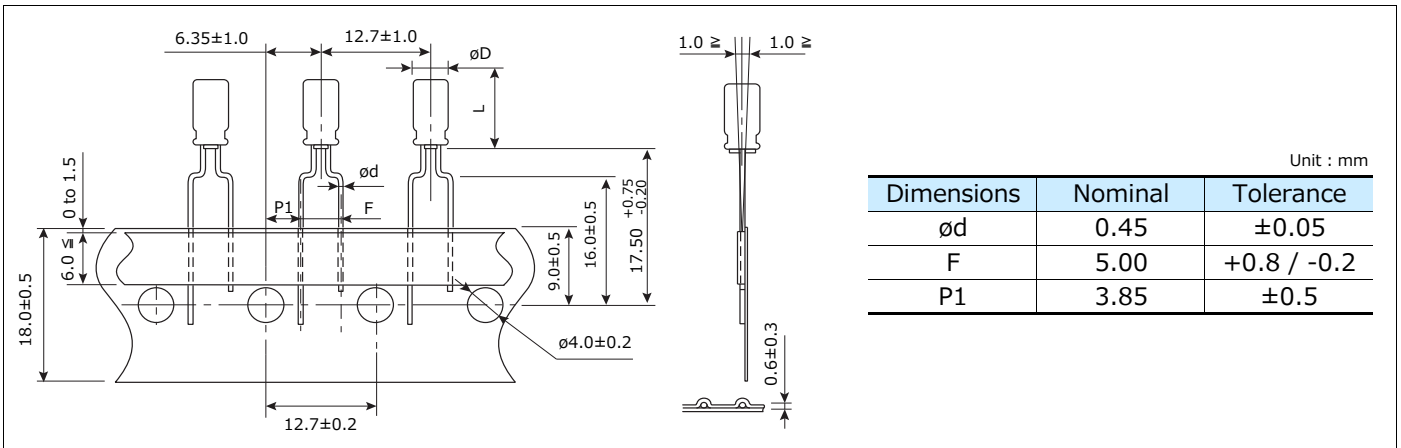

Figure B (Lead space : 2.5 mm / $\phi D \times L$: $\phi 4 \times 5, 7, \phi 5 \times 5, 7$)

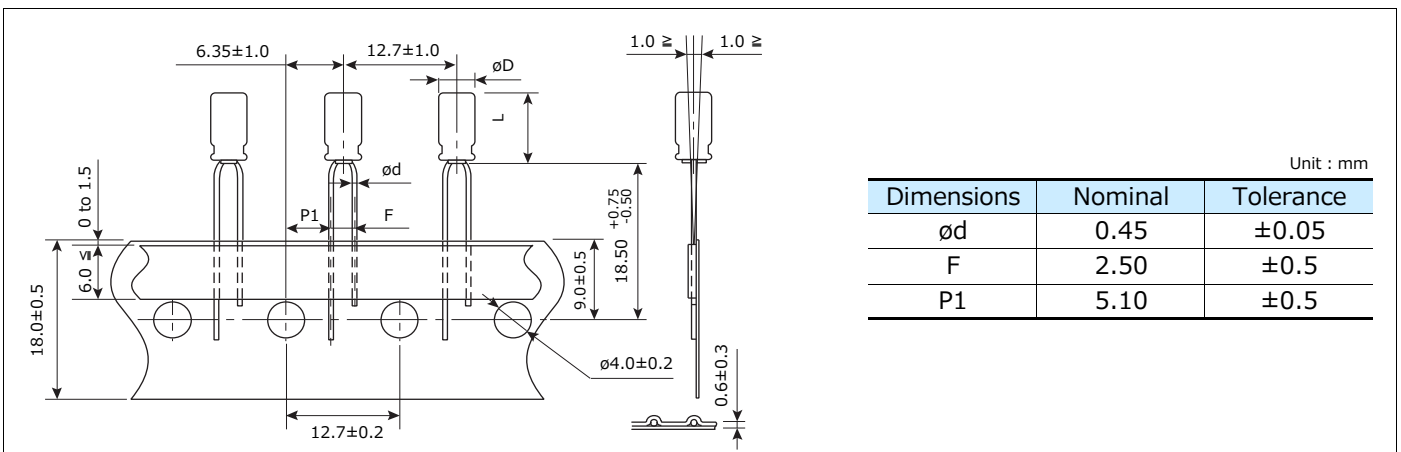

Figure C (Lead space : 2.5 mm / $\phi D \times L$: $\phi 5 \times 11, \phi 6.3 \times 5, 7, 11.2, 15, \phi 8 \times 5, 7$)

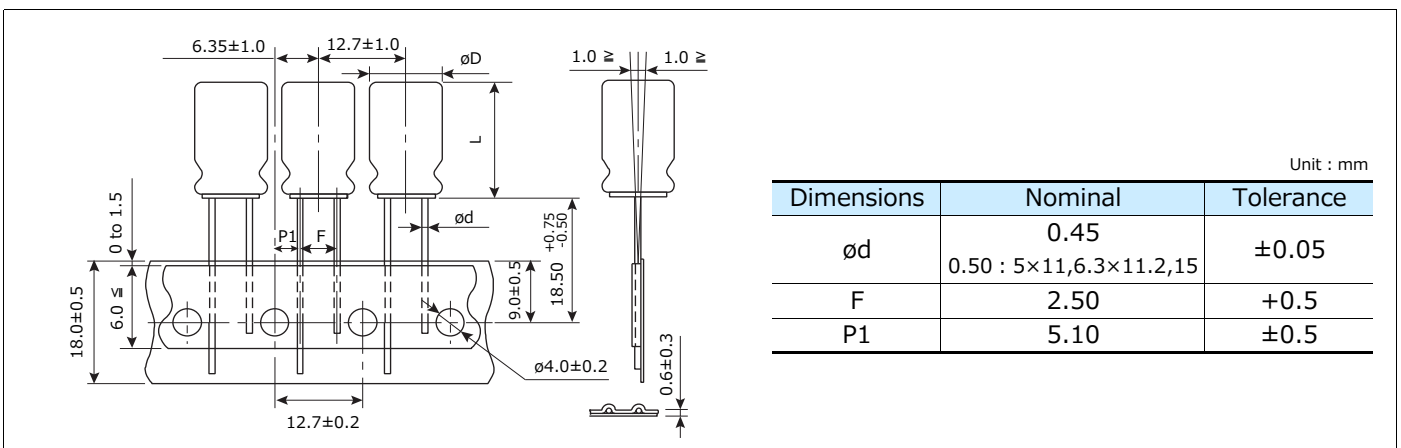

Figure D (Lead space : 5.0 mm / $\phi D \times L$: $\phi 5 \times 11, \phi 6.3 \times 11.2, 15$)

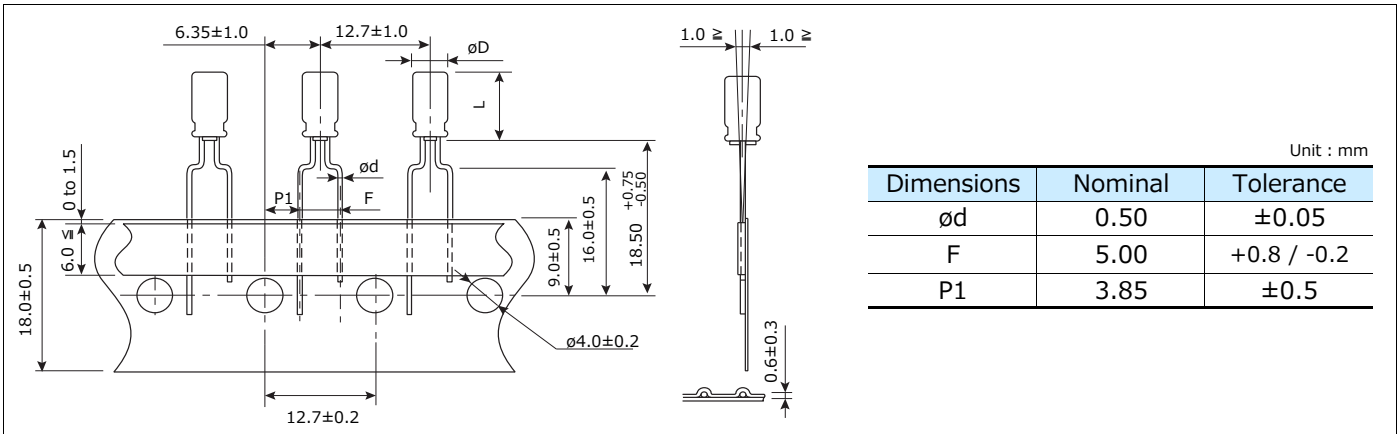

Figure E (Lead space : 5 mm / $\phi D \times L$: $\phi 8 \times 5, 7, 11.5, 15, 20$)

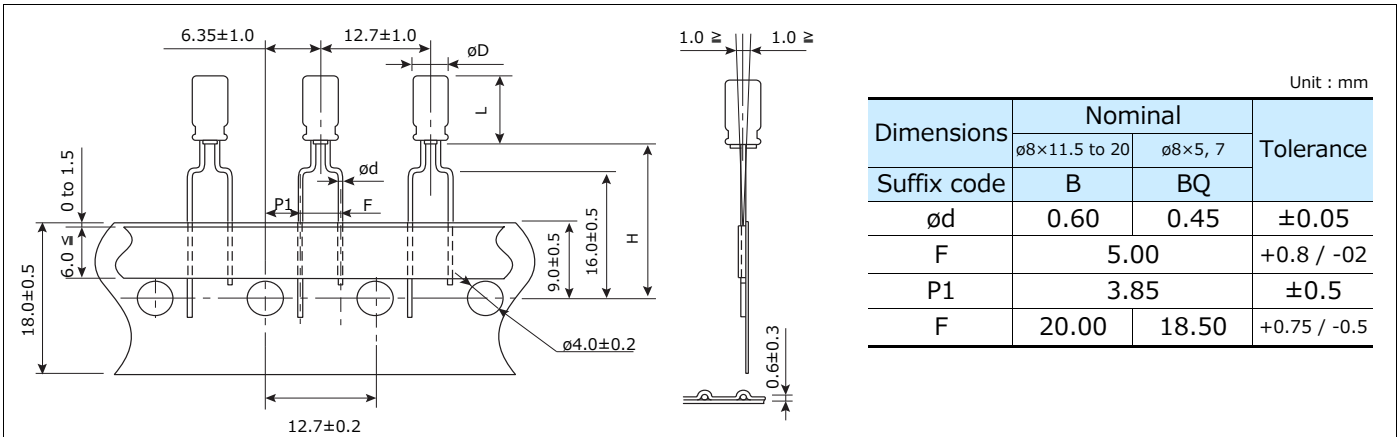

Figure F (Lead space : 5 mm / $\phi D \times L$: $\phi 10 \times 12.5, 16, 20, 25$)

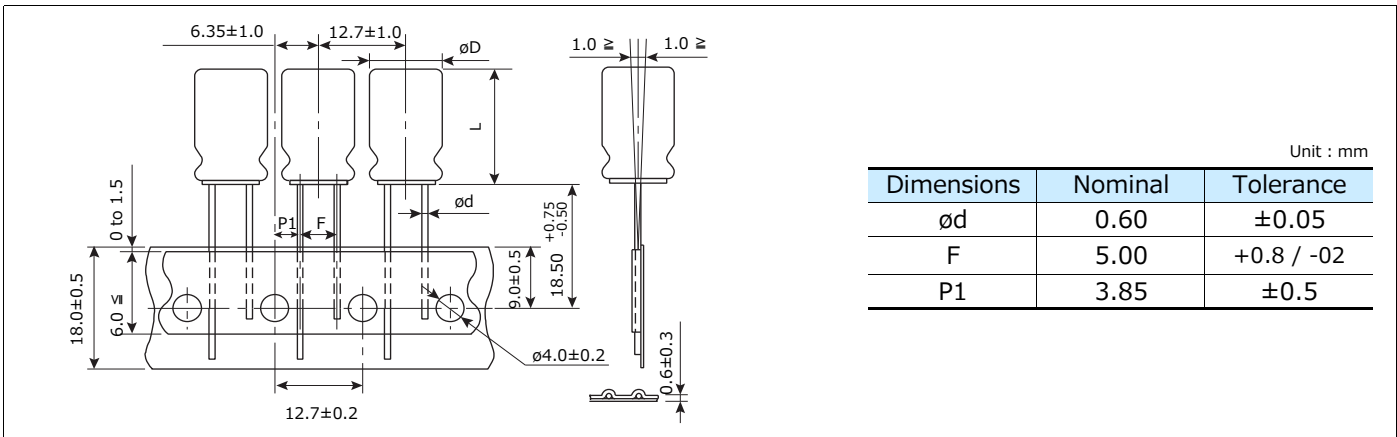

Figure G (Lead space : 5 mm / $\phi D \times L$: $\phi 12.5 \times 15, 20, 25$)

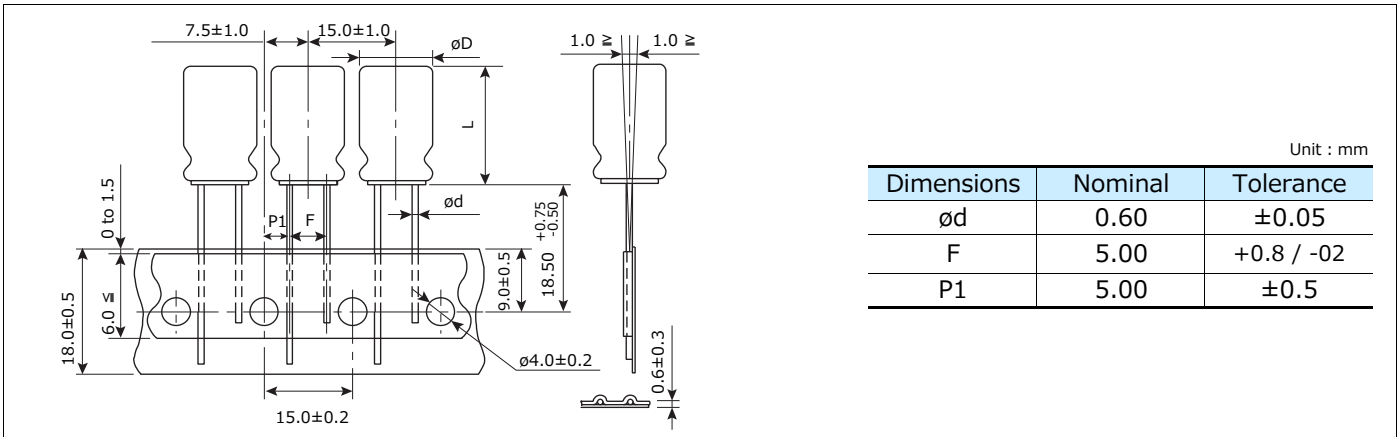
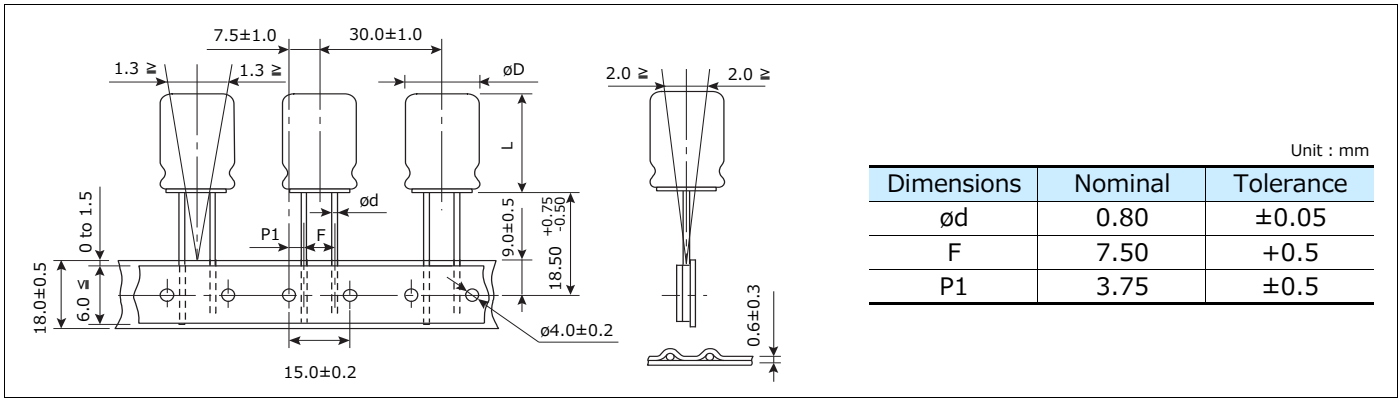

Figure H (Lead space : 7.5 mm / $\phi D \times L$: $\phi 16 \times 15, 20, 25, \phi 18 \times 15, 20, 25$)



Packaging Specifications

Dimensions of outer carton box		Dimensions				
		$\phi 4$ to $\phi 5$	$\phi 6.3$	$\phi 8$	$\phi 10, \phi 12.5$	$\phi 16, \phi 18$
	a	340 max.	340 max.	340 max.	340 max.	340 max.
	b	to 55 max.	to 55 max.	to 55 max.	55 to 66 max.	62 to 75 max.
	c	170 to 210 max.	270 max.	230 max.	170 to 270 max.	225 to 310 max.
	Packaging Qty.	2000 pcs.	2000 pcs.	1000 pcs.	500 pcs.	250 pcs.

Unit : mm

● Lead forming type (Snap-in)

Lead formed Aluminium Electrolytic Capacitor for self mounting, for rationalization and upgrade of soldering process.

Shape of lead wire

ϕD	Dimensions
4, 5, 6.3, 8	
10, 12.5, 16, 18	

Dimensions

ϕD	$H1 \pm 0.5$	H2	H3	$F \pm 0.5$	P	E max.	ϕd	for PWB	
								hole dia. ϕ	thick ness
5.0	4.5	2.7	2.5	5.0	1.0	1.0	0.5	0.9	1.6
6.3	4.5	2.7	2.5	5.0	1.0	1.0	0.5	1.0	1.6
8.0	4.5	2.7	2.5	5.0	1.0	1.0	0.6	1.0	1.6
10.0	4.5	2.7	—	5.0	1.0	1.0	0.6	1.0	1.6
12.5	4.5	2.7	—	5.0	1.0 / 0.9	1.0	0.6 / 0.8	1.0 / 1.1	1.6
16.0	4.5	2.7	—	7.5	0.9	1.0	0.8	1.1	1.6
18.0	4.5	2.7	—	7.5	0.9	1.0	0.8	1.1	1.6

Unit : mm

Series KA/KS Dimensions

ϕD	$H1 \pm 0.5$	H2	$H3 \pm 0.3$	$F \pm 0.5$	P	E max.	ϕd	for PWB	
								hole dia. ϕ	thick ness
4.0	4.5	2.7	1.5	5.0	0.95	1.0	0.45	0.9	1.6
5.0	4.5	2.7	1.5	5.0	0.95	1.0	0.45	0.9	1.6
6.3	4.5	2.7	1.5	5.0	0.95	1.0	0.45	0.9	1.6
8.0	4.5	2.7	1.5	5.0	0.95	1.0	0.45	0.9	1.6

Unit : mm

Radial Lead Type

FR-A series



Features

- Endurance : 105 °C 5000 h to 10000 h
- Low ESR (Same as FM Series)
- RoHS compliant

Country of origin

- Malaysia

Specifications

Category temp. range	-40 °C to +105 °C									
Rated voltage range	6.3 V to 100 V									
Capacitance range	4.7 μF to 8200 μF									
Capacitance tolerance	±20 % (120 Hz / +20°C)									
Leakage current	$I \leq 0.01 CV (\mu A)$ After 2 minutes									
Dissipation factor (tan δ)	Rated voltage (V)	6.3	10	16	25	35	50	63	100	(120 Hz / +20°C)
	Dissipation factor (tan δ)	0.22	0.19	0.16	0.14	0.12	0.10	0.09	0.08	
Endurance	For capacitance value $\geq 1000 \mu F$, add 0.02 per every 1000 μF.									
	After following life test with DC voltage and +105 °C±2 °C ripple current value applied (The sum of DC and ripple peak voltage shall not exceed the rated working voltage) when the capacitors are restored to 20 °C, the capacitors shall meet the limits specified bellow.									
	Duration									
	$\varnothing 5 \times 11, \varnothing 6.3 \times 11.2$: 5000 h $\varnothing 8 \times 11.5, \varnothing 10 \times 12.5$: 6000 h (* Only EEUFR1V331U ($\varnothing 10 \times 12.5$) 5000 h) $\varnothing 8 \times 15, \varnothing 10 \times 16$: 8000 h, $\varnothing 8 \times 20$: 9000 h $\varnothing 10 \times 20$ to $\varnothing 10 \times 25, \varnothing 12.5 \times 20$ to $\varnothing 12.5 \times 35, \varnothing 16 \times 20$ to $\varnothing 16 \times 25$: 10000 h									
Capacitance change	Within ±25 % of the initial value (6.3 V to 10 V : ±30 %)									
Dissipation factor (tan δ)	≤ 200 % of the initial limit									
DC leakage current	Within the initial limit									
Shelf life	After storage for 1000 h at +105 °C±2 °C with no voltage applied and then being stabilized at +20 °C, capacitors shall meet the limits specified in endurance. (With voltage treatment)									

Frequency correction factor for ripple current

Freq. (Hz)	60	120	1 k	10 k	100 k
4.7 to 33	0.45	0.55	0.75	0.90	1.00
47 to 330	0.60	0.70	0.85	0.95	1.00
390 to 1000	0.65	0.75	0.90	0.98	1.00
1200 to 8200	0.75	0.80	0.95	1.00	1.00

Dimensions

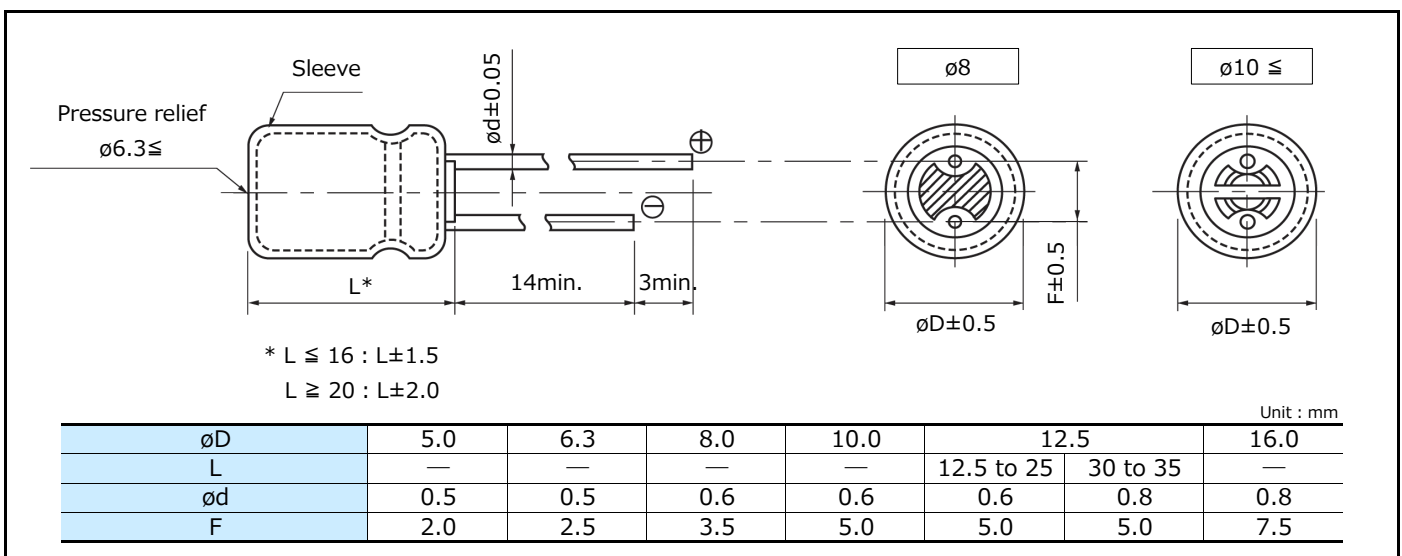

Case size/ Impedance/ Ripple current

R. voltage Case size (mm) (ϕ D×L)	6.3 V to 35 V			50 V		
	Impedance* ¹ (Ω)		Ripple current* ¹ (mA rms)	Impedance* ¹ (Ω)		Ripple current* ¹ (mA rms)
	+20 °C	-10 °C	+105 °C	+20 °C	-10 °C	+105 °C
5 × 11	0.300	1.000	280	0.340	1.130	250
6.3 × 11.2	0.130	0.430	455	0.140	0.460	405
8 × 11.5	0.056	0.168	950	0.061	0.183	870
8 × 15	0.041	0.123	1240	0.045	0.135	1140
8 × 20	0.030	0.090	1560	0.033	0.099	1430
10 × 12.5	0.043	0.114	1290	0.042	0.126	1170
10 × 16	0.028	0.078	1790	0.030	0.090	1650
10 × 20	0.020	0.057	2180	0.023	0.069	1890
10 × 25	0.018	0.054	2470	0.022	0.066	2150
12.5 × 20	0.018	0.045	2600	0.022	0.055	2260
12.5 × 25	0.015	0.038	3190	0.018	0.045	2660
12.5 × 30	0.013	0.033	3630	0.016	0.040	3160
12.5 × 35	0.012	0.030	3750	0.014	0.035	3270
16 × 20	0.017	0.043	3300	0.019	0.048	2870
16 × 25	0.014	0.035	3820	0.016	0.040	3320

R. voltage Case size (mm) (ϕ D×L)	63 V		
	Impedance* ¹ (Ω)		Ripple current* ¹ (mA rms)
	+20 °C	-10 °C	+105 °C
5 × 11	0.510	2.040	175
6.3 × 11.2	0.210	0.840	284
8 × 11.5	0.092	0.368	566
8 × 15	0.068	0.272	741
8 × 20	0.050	0.200	930
10 × 12.5	0.063	0.252	761
10 × 16	0.045	0.180	1073
10 × 20	0.035	0.140	1229
10 × 25	0.033	0.132	1500
12.5 × 20	0.033	0.125	1582
12.5 × 25	0.027	0.092	1995
12.5 × 30	0.024	0.082	2528
12.5 × 35	0.021	0.071	2780
16 × 20	0.029	0.093	2153
16 × 25	0.024	0.074	2988

R. voltage Case size (mm) (ϕ D×L)	100 V		
	Impedance* ¹ (Ω)		Ripple current* ¹ (mA rms)
	+20 °C	-10 °C	+105 °C
10 × 20	0.084	0.336	1500

*1: 100 kHz

Characteristics list

Rated voltage (V)	Capacitance (±20 %) (μF)	Case size (mm)		Specification			Lead length (mm)			Part No.	Min. Packaging Q'ty (PCS)		
		øD	L	Ripple current* ¹ (mA rms)	Impe-dance* ² (Ω)	Endu-rance (h)	Lead dia. (ød)	Lead space			Straight leads	Taping	
								Straight	Taping *B				Taping *H
6.3	150	5.0	11.0	280	0.300	5000	0.5	2.0	5.0	2.5	EEUFR0J151()	200	2000
	220	6.3	11.2	455	0.130	5000	0.5	2.5	5.0	2.5	EEUFR0J221()	200	2000
	330	6.3	11.2	455	0.130	5000	0.5	2.5	5.0	2.5	EEUFR0J331()	200	2000
	470	6.3	11.2	455	0.130	5000	0.5	2.5	5.0	2.5	EEUFR0J471()	200	2000
	820	8.0	11.5	950	0.056	6000	0.6	3.5	5.0	—	EEUFR0J821()	200	1000
	1000	8.0	11.5	950	0.056	6000	0.6	3.5	5.0	—	EEUFR0J102()	200	1000
	1200	8.0	15.0	1240	0.041	8000	0.6	3.5	5.0	—	EEUFR0J122L()	200	1000
		10.0	12.5	1290	0.043	6000	0.6	5.0	5.0	—	EEUFR0J122()	200	500
	1500	8.0	20.0	1560	0.030	9000	0.6	3.5	5.0	—	EEUFR0J152L()	200	1000
	1800	10.0	16.0	1790	0.028	8000	0.6	5.0	5.0	—	EEUFR0J182()	200	500
	2200	10.0	20.0	2180	0.020	10000	0.6	5.0	5.0	—	EEUFR0J222()	200	500
	2700	10.0	25.0	2470	0.018	10000	0.6	5.0	5.0	—	EEUFR0J272L()	200	500
	3300	10.0	25.0	2470	0.018	10000	0.6	5.0	5.0	—	EEUFR0J332L()	200	500
	3900	12.5	20.0	2600	0.018	10000	0.6	5.0	5.0	—	EEUFR0J392()	200	500
	4700	12.5	25.0	3190	0.015	10000	0.6	5.0	5.0	—	EEUFR0J472()	200	500
	5600	12.5	30.0	3630	0.013	10000	0.8	5.0	—	—	EEUFR0J562L	100	—
	6800	12.5	35.0	3750	0.012	10000	0.8	5.0	—	—	EEUFR0J682L	100	—
		16.0	20.0	3300	0.017	10000	0.8	7.5	7.5	—	EEUFR0J682S()	100	250
8200	16.0	25.0	3820	0.014	10000	0.8	7.5	7.5	—	EEUFR0J822()	100	250	
10	100	5.0	11.0	280	0.300	5000	0.5	2.0	5.0	2.5	EEUFR1A101()	200	2000
	150	5.0	11.0	280	0.300	5000	0.5	2.0	5.0	2.5	EEUFR1A151()	200	2000
	220	6.3	11.2	455	0.130	5000	0.5	2.5	5.0	2.5	EEUFR1A221()	200	2000
	270	6.3	11.2	455	0.130	5000	0.5	2.5	5.0	2.5	EEUFR1A271()	200	2000
	470	8.0	11.5	950	0.056	6000	0.6	3.5	5.0	—	EEUFR1A471()	200	1000
	680	8.0	11.5	950	0.056	6000	0.6	3.5	5.0	—	EEUFR1A681()	200	1000
	820	10.0	12.5	1290	0.043	6000	0.6	5.0	5.0	—	EEUFR1A821()	200	500
	1000	10.0	16.0	1790	0.028	8000	0.6	5.0	5.0	—	EEUFR1A102()	200	500
		8.0	15.0	1240	0.041	8000	0.6	3.5	5.0	—	EEUFR1A102L()	200	1000
	1500	8.0	20.0	1560	0.030	9000	0.6	3.5	5.0	—	EEUFR1A152L()	200	1000
		10.0	16.0	1790	0.028	8000	0.6	5.0	5.0	—	EEUFR1A152()	200	500
	1800	10.0	20.0	2180	0.020	10000	0.6	5.0	5.0	—	EEUFR1A182()	200	500
	2200	10.0	25.0	2470	0.018	10000	0.6	5.0	5.0	—	EEUFR1A222L()	200	500
	3300	12.5	20.0	2600	0.018	10000	0.6	5.0	5.0	—	EEUFR1A332()	200	500
	3900	12.5	25.0	3190	0.015	10000	0.6	5.0	5.0	—	EEUFR1A392()	200	500
	4700	12.5	30.0	3630	0.013	10000	0.8	5.0	—	—	EEUFR1A472L	100	—
		16.0	20.0	3300	0.017	10000	0.8	7.5	7.5	—	EEUFR1A472S()	100	250
	5600	12.5	35.0	3750	0.012	10000	0.8	5.0	—	—	EEUFR1A562L	100	—
6800	12.5	35.0	3750	0.012	10000	0.8	5.0	—	—	EEUFR1A682L	100	—	
	16.0	25.0	3820	0.014	10000	0.8	7.5	7.5	—	EEUFR1A682()	100	250	

*1: Ripple current (100 kHz / +105 °C)

*2: Impedance (100 kHz / +20 °C)

• When requesting taped product, please put the letter "B" or "H" between the "()".

Lead wire pitch *B=5 mm, 7.5 mm, H=2.5 mm.

• Please refer to the page of "Taping dimensions".

Characteristics list

Rated voltage (V)	Capacitance (±20 %) (μF)	Case size (mm)		Specification			Lead length (mm)				Part No.	Min. Packaging Q'ty (PCS)	
		øD	L	Ripple current* ¹ (mA rms)	Impe-dance* ² (Ω)	Endu-rance (h)	Lead dia. (ød)	Lead space				Straight leads	Taping
								Straight	Taping *B	Taping *H			
16	68	5.0	11.0	280	0.300	5000	0.5	2.0	5.0	2.5	EEUFR1C680()	200	2000
	100	5.0	11.0	280	0.300	5000	0.5	2.0	5.0	2.5	EEUFR1C101()	200	2000
	120	6.3	11.2	455	0.130	5000	0.5	2.5	5.0	2.5	EEUFR1C121()	200	2000
	220	6.3	11.2	455	0.130	5000	0.5	2.5	5.0	2.5	EEUFR1C221()	200	2000
	470	8.0	11.5	950	0.056	6000	0.6	3.5	5.0	—	EEUFR1C471()	200	1000
	680	8.0	15.0	1240	0.041	8000	0.6	3.5	5.0	—	EEUFR1C681L()	200	1000
		10.0	12.5	1290	0.043	6000	0.6	5.0	5.0	—	EEUFR1C681()	200	500
	1000	8.0	20.0	1560	0.030	9000	0.6	3.5	5.0	—	EEUFR1C102L()	200	1000
		10.0	16.0	1790	0.028	8000	0.6	5.0	5.0	—	EEUFR1C102()	200	500
	1500	10.0	20.0	2180	0.020	10000	0.6	5.0	5.0	—	EEUFR1C152()	200	500
		10.0	25.0	2470	0.018	10000	0.6	5.0	5.0	—	EEUFR1C152L()	200	500
	1800	10.0	25.0	2470	0.018	10000	0.6	5.0	5.0	—	EEUFR1C182L()	200	500
	2200	12.5	20.0	2600	0.018	10000	0.6	5.0	5.0	—	EEUFR1C222()	200	500
	2700	12.5	25.0	3190	0.015	10000	0.6	5.0	5.0	—	EEUFR1C272()	200	500
	3300	12.5	30.0	3630	0.013	10000	0.8	5.0	—	—	EEUFR1C332L	100	—
		16.0	20.0	3300	0.017	10000	0.8	7.5	7.5	—	EEUFR1C332S()	100	250
	3900	12.5	35.0	3750	0.012	10000	0.8	5.0	—	—	EEUFR1C392L	100	—
		16.0	20.0	3300	0.017	10000	0.8	7.5	7.5	—	EEUFR1C392S()	100	250
4700	12.5	35.0	3750	0.012	10000	0.8	5.0	—	—	EEUFR1C472L	100	—	
	16.0	25.0	3820	0.014	10000	0.8	7.5	7.5	—	EEUFR1C472()	100	250	
5600	16.0	25.0	3820	0.014	10000	0.8	7.5	7.5	—	EEUFR1C562()	100	250	
25	47	5.0	11.0	280	0.300	5000	0.5	2.0	5.0	2.5	EEUFR1E470()	200	2000
	68	5.0	11.0	280	0.300	5000	0.5	2.0	5.0	2.5	EEUFR1E680()	200	2000
	100	6.3	11.2	455	0.130	5000	0.5	2.5	5.0	2.5	EEUFR1E101()	200	2000
	150	6.3	11.2	455	0.130	5000	0.5	2.5	5.0	2.5	EEUFR1E151()	200	2000
	220	8.0	11.5	950	0.056	6000	0.6	3.5	5.0	—	EEUFR1E221()	200	1000
	330	8.0	11.5	950	0.056	6000	0.6	3.5	5.0	—	EEUFR1E331()	200	1000
	390	8.0	15.0	1240	0.041	8000	0.6	3.5	5.0	—	EEUFR1E391L()	200	1000
	470	8.0	15.0	1240	0.041	8000	0.6	3.5	5.0	—	EEUFR1E471Y()	200	1000
		8.0	20.0	1560	0.030	9000	0.6	3.5	5.0	—	EEUFR1E471L()	200	1000
		10.0	12.5	1290	0.043	6000	0.6	5.0	5.0	—	EEUFR1E471()	200	500
	560	8.0	20.0	1560	0.030	9000	0.6	3.5	5.0	—	EEUFR1E561L()	200	1000
	680	8.0	20.0	1560	0.030	9000	0.6	3.5	5.0	—	EEUFR1E681L()	200	1000
		10.0	16.0	1790	0.028	8000	0.6	5.0	5.0	—	EEUFR1E681()	200	500
	820	10.0	20.0	2180	0.020	10000	0.6	5.0	5.0	—	EEUFR1E821()	200	500
	1000	10.0	20.0	2180	0.020	10000	0.6	5.0	5.0	—	EEUFR1E102()	200	500
		10.0	25.0	2470	0.018	10000	0.6	5.0	5.0	—	EEUFR1E102L()	200	500
	1200	10.0	25.0	2470	0.018	10000	0.6	5.0	5.0	—	EEUFR1E122L()	200	500
	1500	12.5	20.0	2600	0.018	10000	0.6	5.0	5.0	—	EEUFR1E152()	200	500
	1800	12.5	25.0	3190	0.015	10000	0.6	5.0	5.0	—	EEUFR1E182()	200	500
		16.0	20.0	3300	0.017	10000	0.8	7.5	7.5	—	EEUFR1E182S()	100	250
	2200	12.5	30.0	3630	0.013	10000	0.8	5.0	—	—	EEUFR1E222L	100	—
		16.0	20.0	3300	0.017	10000	0.8	7.5	7.5	—	EEUFR1E222S()	100	250
	2700	12.5	35.0	3750	0.012	10000	0.8	5.0	—	—	EEUFR1E272L	100	—
16.0		20.0	3300	0.017	10000	0.8	7.5	7.5	—	EEUFR1E272S()	100	250	
3300	16.0	25.0	3820	0.014	10000	0.8	7.5	7.5	—	EEUFR1E332()	100	250	

*1: Ripple current (100 kHz / +105 °C)

*2: Impedance (100 kHz / +20 °C)

• When requesting taped product, please put the letter "B" or "H" between the "()".

Lead wire pitch *B=5 mm, 7.5 mm, H=2.5 mm.

• Please refer to the page of "Taping dimensions".

Characteristics list

Rated voltage (V)	Capacitance (±20 %) (μF)	Case size (mm)		Specification			Lead length (mm)				Part No.	Min. Packaging Q'ty (PCS)		
		øD	L	Ripple current*1 (mA rms)	Impe-dance*2 (Ω)	Endu-rance (h)	Lead dia. (ød)	Lead space				Straight leads	Taping	
								Straight	Taping *B	Taping *H				
35	33	5.0	11.0	280	0.300	5000	0.5	2.0	5.0	2.5	EEUFR1V330()	200	2000	
	68	6.3	11.2	455	0.130	5000	0.5	2.5	5.0	2.5	EEUFR1V680()	200	2000	
	100	8.0	11.5	950	0.056	6000	0.6	3.5	5.0	—	EEUFR1V101()	200	1000	
	180	8.0	11.5	950	0.056	6000	0.6	3.5	5.0	—	EEUFR1V181()	200	1000	
	220	8.0	11.5	950	0.056	6000	0.6	3.5	5.0	—	EEUFR1V221()	200	1000	
	270	8.0	15.0	1240	0.041	8000	0.6	3.5	5.0	—	EEUFR1V271L()	200	1000	
		10.0	12.5	1290	0.043	6000	0.6	5.0	5.0	—	EEUFR1V271()	200	500	
	330	10.0	12.5	1330	0.043	5000	0.6	5.0	5.0	—	EEUFR1V331U()	200	500	
	390	8.0	20.0	1560	0.030	9000	0.6	3.5	5.0	—	EEUFR1V391L()	200	1000	
	470	8.0	20.0	1560	0.030	9000	0.6	3.5	5.0	—	EEUFR1V471L()	200	1000	
		10.0	16.0	1790	0.028	8000	0.6	5.0	5.0	—	EEUFR1V471()	200	500	
	560	10.0	20.0	2180	0.020	10000	0.6	5.0	5.0	—	EEUFR1V561()	200	500	
	680	10.0	20.0	2180	0.020	10000	0.6	5.0	5.0	—	EEUFR1V681()	200	500	
		10.0	25.0	2470	0.018	10000	0.6	5.0	5.0	—	EEUFR1V681L()	200	500	
	820	10.0	25.0	2470	0.018	10000	0.6	5.0	5.0	—	EEUFR1V821L()	200	500	
	1000	12.5	20.0	2600	0.018	10000	0.6	5.0	5.0	—	EEUFR1V102()	200	500	
	1200	12.5	25.0	3190	0.015	10000	0.6	5.0	5.0	—	EEUFR1V122()	200	500	
	1500	12.5	30.0	3630	0.013	10000	0.8	5.0	—	—	EEUFR1V152L()	100	—	
		16.0	20.0	3300	0.017	10000	0.8	7.5	7.5	—	EEUFR1V152S()	100	250	
	1800	12.5	35.0	3750	0.012	10000	0.8	5.0	—	—	EEUFR1V182L()	100	—	
16.0		25.0	3820	0.014	10000	0.8	7.5	7.5	—	EEUFR1V182()	100	250		
2200	12.5	35.0	3750	0.012	10000	0.8	5.0	—	—	EEUFR1V222L()	100	—		
	16.0	25.0	3820	0.014	10000	0.8	7.5	7.5	—	EEUFR1V222()	100	250		
50	4.7	5.0	11.0	185	0.620	5000	0.5	2.0	5.0	2.5	EEUFR1H47()	200	2000	
	10	5.0	11.0	250	0.340	5000	0.5	2.0	5.0	2.5	EEUFR1H100()	200	2000	
	22	5.0	11.0	250	0.340	5000	0.5	2.0	5.0	2.5	EEUFR1H220()	200	2000	
	47	6.3	11.2	405	0.140	5000	0.5	2.5	5.0	—	EEUFR1H470()	200	2000	
	56	6.3	11.2	405	0.140	5000	0.5	2.5	5.0	2.5	EEUFR1H560()	200	2000	
	100	8.0	11.5	870	0.061	6000	0.6	3.5	5.0	—	EEUFR1H101()	200	1000	
	120	8.0	15.0	1140	0.045	8000	0.6	3.5	5.0	—	EEUFR1H121L()	200	1000	
	150	10.0	12.5	1170	0.042	6000	0.6	5.0	5.0	—	EEUFR1H151()	200	500	
	180	8.0	20.0	1430	0.033	9000	0.6	3.5	5.0	—	EEUFR1H181L()	200	1000	
	220	10.0	16.0	1650	0.030	8000	0.6	5.0	5.0	—	EEUFR1H221()	200	500	
	270	10.0	20.0	1890	0.023	10000	0.6	5.0	5.0	—	EEUFR1H271()	200	500	
	330	10.0	25.0	2150	0.022	10000	0.6	5.0	5.0	—	EEUFR1H331L()	200	500	
	470	12.5	20.0	2260	0.022	10000	0.6	5.0	5.0	—	EEUFR1H471()	200	500	
	560	12.5	25.0	2660	0.018	10000	0.6	5.0	5.0	—	EEUFR1H561()	200	500	
	680	12.5	30.0	3160	0.016	10000	0.8	5.0	—	—	EEUFR1H681L()	100	—	
	820	12.5	35.0	3270	0.014	10000	0.8	5.0	—	—	EEUFR1H821L()	100	—	
		16.0	20.0	2870	0.019	10000	0.8	7.5	7.5	—	EEUFR1H821S()	100	250	
	1000	16.0	25.0	3320	0.016	10000	0.8	7.5	7.5	—	EEUFR1H102()	100	250	
	63	18	5.0	11.0	175	0.510	5000	0.5	2.0	5.0	2.5	EEUFR1J180()	200	2000
		47	6.3	11.2	284	0.210	5000	0.5	2.5	5.0	2.5	EEUFR1J470()	200	2000
82		8.0	11.5	566	0.092	6000	0.6	3.5	5.0	—	EEUFR1J820()	200	1000	
		8.0	15.0	741	0.068	8000	0.6	3.5	5.0	—	EEUFR1J101L()	200	1000	
100		10.0	12.5	761	0.063	6000	0.6	5.0	5.0	—	EEUFR1J101()	200	500	
		8.0	20.0	930	0.050	9000	0.6	3.5	5.0	—	EEUFR1J121L()	200	1000	
120		10.0	16.0	1073	0.045	8000	0.6	5.0	5.0	—	EEUFR1J121()	200	500	
		8.0	20.0	930	0.050	9000	0.6	3.5	5.0	—	EEUFR1J151L()	200	1000	
150		10.0	16.0	1073	0.045	8000	0.6	5.0	5.0	—	EEUFR1J151()	200	500	
		10.0	20.0	1229	0.035	10000	0.6	5.0	5.0	—	EEUFR1J181()	200	500	
220		10.0	25.0	1500	0.033	10000	0.6	5.0	5.0	—	EEUFR1J221L()	200	500	
		10.0	20.0	1229	0.035	10000	0.6	5.0	5.0	—	EEUFR1J271U()	200	500	
270		10.0	25.0	1500	0.033	10000	0.6	5.0	5.0	—	EEUFR1J271L()	200	500	
		12.5	20.0	1582	0.033	10000	0.6	5.0	5.0	—	EEUFR1J271()	200	500	
330		12.5	20.0	1582	0.033	10000	0.6	5.0	5.0	—	EEUFR1J331()	200	500	
390		12.5	25.0	1995	0.027	10000	0.6	5.0	5.0	—	EEUFR1J391()	200	500	
470		12.5	25.0	1995	0.027	10000	0.6	5.0	5.0	—	EEUFR1J471()	200	500	
560		12.5	30.0	2528	0.024	10000	0.8	5.0	—	—	EEUFR1J561L()	100	—	
		16.0	20.0	2153	0.029	10000	0.8	7.5	7.5	—	EEUFR1J561S()	100	250	
680		12.5	35.0	2780	0.021	10000	0.8	5.0	—	—	EEUFR1J681L()	100	—	
820	16.0	25.0	2988	0.024	10000	0.8	7.5	7.5	—	EEUFR1J821()	100	250		
100	100	10.0	20.0	1500	0.084	10000	0.6	5.0	5.0	—	EEUFR2A101()	200	500	

*1: Ripple current (100 kHz / +105 °C)

*2: Impedance (100 kHz / +20 °C)

• When requesting taped product, please put the letter "B" or "H" between the "()".

Lead wire pitch *B=5 mm, 7.5 mm, H=2.5 mm.

• Please refer to the page of "Taping dimensions".

Radial Lead Type

FS-A series



Features

- Endurance : 105 °C 5000 h to 10000 h
- Low ESR, Miniaturized (1 size smaller than series FR)
- RoHS compliant

Country of origin

- Malaysia

Specifications

Category temp. range	-40 °C to +105 °C										
Rated voltage range	6.3 V to 100 V										
Capacitance range	27 μF to 10000 μF										
Capacitance tolerance	±20 % (120 Hz / +20°C)										
Leakage current	I ≤ 0.01 CV (μA) After 2 minutes										
Dissipation factor (tan δ)	Rated voltage (V)	6.3	10	16	25	35	50	63	80	100	(120 Hz / +20°C)
	Dissipation factor (tan δ)	0.22	0.19	0.16	0.14	0.12	0.10	0.09	0.08	0.08	
Endurance	For capacitance value ≥ 1000 μF, add 0.02 per every 1000 μF.										
	After following life test with DC voltage and +105 °C±2 °C ripple current value applied (The sum of DC and ripple peak voltage shall not exceed the rated working voltage) when the capacitors are restored to 20 °C, the capacitors shall meet the limits specified bellow.										
	Duration										
	ø5×11, ø6.3×11.2 : 5000 h ø8×11.5, ø10×12.5 : 6000 h ø8×15, ø10×16 : 8000 h, ø8×20 : 9000 h ø10×20 to ø10×25, ø12.5×20 to ø12.5×35, ø16×20 to ø16×25 : 10000 h										
	Capacitance change	Within ±25 % of the initial value (6.3 V to 10 V : ±30 %)									
	Dissipation factor (tan δ)	≤ 200 % of the initial limit									
	DC leakage current	Within the initial limit									
Shelf life	After storage for 1000 h at +105 °C±2 °C with no voltage applied and then being stabilized at +20 °C, capacitors shall meet the limits specified in endurance. (With voltage treatment)										

Frequency correction factor for ripple current

Freq. (Hz)	60	120	1 k	10 k	100 k to
27 to 33	0.45	0.55	0.75	0.90	1.00
47 to 330	0.60	0.70	0.85	0.95	1.00
390 to 1000	0.65	0.75	0.90	0.98	1.00
1200 to 10000	0.75	0.80	0.95	1.00	1.00

Dimensions

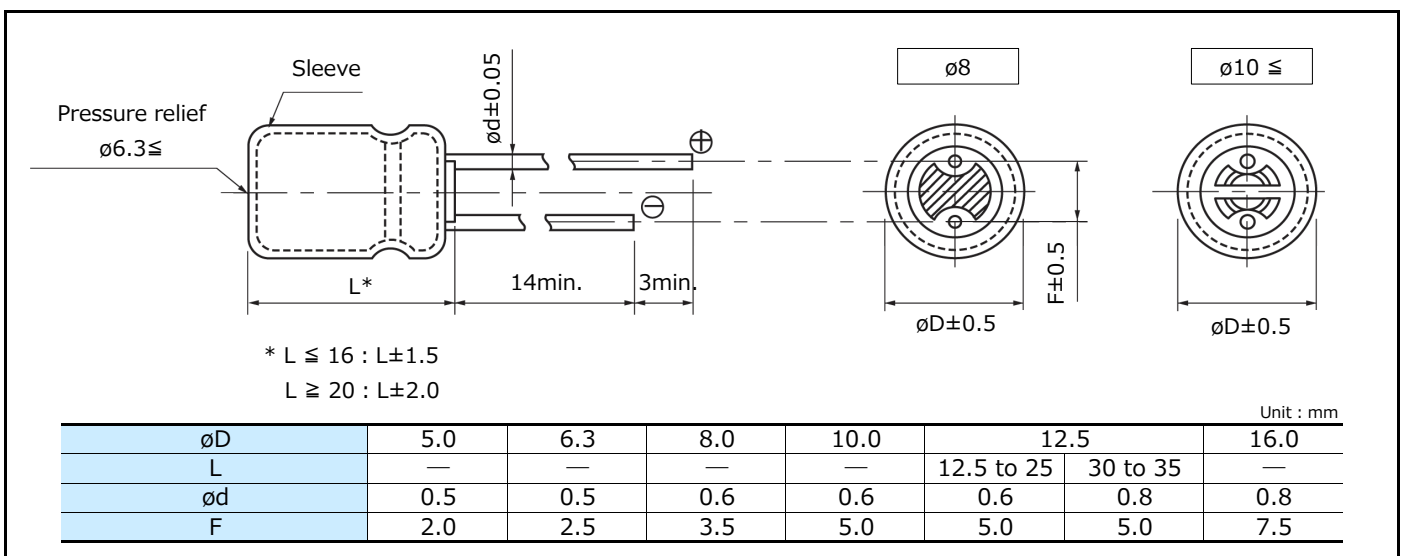

Case size/ Impedance/ Ripple current

R. voltage Case size (mm) (ϕ D×L)	6.3 V to 35 V			50 V		
	Impedance* ¹ (Ω)		Ripple current* ¹ (mA rms)	Impedance* ¹ (Ω)		Ripple current* ¹ (mA rms)
	+20 °C	-10 °C	+105 °C	+20 °C	-10 °C	+105 °C
5 × 11	0.300	1.000	280	0.340	1.130	250
6.3 × 11.2	0.130	0.430	455	—	—	—
8 × 11.5	0.056	0.168	950	—	—	—
8 × 15	0.041	0.123	1240	0.045	0.135	1140
8 × 20	0.030	0.090	1560	0.033	0.099	1430
10 × 12.5	0.043	0.114	1290	—	—	—
10 × 16	0.028	0.078	1790	—	—	—
10 × 20	0.020	0.057	2180	0.023	0.069	1890
10 × 25	0.018	0.054	2470	0.022	0.066	2150
12.5 × 20	0.018	0.045	2600	—	—	—
12.5 × 25	0.015	0.038	3190	0.018	0.045	2660
12.5 × 30	0.013	0.033	3630	0.016	0.040	3160
12.5 × 35	0.012	0.030	3750	0.014	0.035	3270
16 × 20	0.017	0.043	3300	—	—	—
16 × 25	0.014	0.035	3820	0.016	0.040	3320

R. voltage Case size (mm) (ϕ D×L)	63 V			80 V to 100 V		
	Impedance* ¹ (Ω)		Ripple current* ¹ (mA rms)	Impedance* ¹ (Ω)		Ripple current* ¹ (mA rms)
	+20 °C	-10 °C	+105 °C	+20 °C	-10 °C	+105 °C
5 × 11	0.510	2.040	175	—	—	—
6.3 × 11.2	—	—	—	—	—	—
8 × 11.5	—	—	—	0.160	0.720	490
8 × 15	0.068	0.272	741	0.112	0.504	590
8 × 20	0.050	0.200	930	0.096	0.432	810
10 × 12.5	0.063	0.252	761	0.112	0.448	600
10 × 16	0.045	0.180	1073	0.072	0.288	930
10 × 20	—	—	—	0.054	0.224	1120
10 × 25	0.033	0.132	1500	0.044	0.176	1200
12.5 × 20	0.033	0.125	1582	0.043	0.135	1400
12.5 × 25	0.027	0.092	1995	0.034	0.108	1800
12.5 × 30	—	—	—	0.030	0.099	2200
12.5 × 35	0.021	0.071	2780	0.023	0.070	2380
16 × 20	0.029	0.093	2153	0.032	0.108	1450
16 × 25	0.024	0.074	2988	0.025	0.076	2500

*1: 100 kHz

Characteristics list

Rated voltage (V)	Capacitance (±20 %) (μF)	Case size (mm)		Specification			Lead length (mm)				Part No.	Min. Packaging Q'ty (PCS)	
		øD	L	Ripple current* ¹ (mA rms)	Impe-dance* ² (Ω)	Endu-rance (h)	Lead dia. (ød)	Lead space				Straight leads	Taping
								Straight	Taping *B	Taping *H			
6.3	220	5.0	11.0	280	0.300	5000	0.5	2.0	5.0	2.5	EEUFS0J221()	200	2000
	1500	8.0	15.0	1240	0.041	8000	0.6	3.5	5.0	—	EEUFS0J152L()	200	1000
		10.0	12.5	1290	0.043	6000	0.6	5.0	5.0	—	EEUFS0J152()	200	500
	1800	8.0	20.0	1560	0.030	9000	0.6	3.5	5.0	—	EEUFS0J182L()	200	1000
	2000	8.0	20.0	1560	0.030	9000	0.6	3.5	5.0	—	EEUFS0J202L()	200	1000
		10.0	16.0	1790	0.028	8000	0.6	5.0	5.0	—	EEUFS0J202()	200	500
	2200	10.0	16.0	1790	0.028	8000	0.6	5.0	5.0	—	EEUFS0J222()	200	500
	2700	10.0	20.0	2180	0.020	10000	0.6	5.0	5.0	—	EEUFS0J272()	200	500
	3300	10.0	20.0	2180	0.020	10000	0.6	5.0	5.0	—	EEUFS0J332()	200	500
	3900	10.0	25.0	2470	0.018	10000	0.6	5.0	5.0	—	EEUFS0J392L()	200	500
	4700	12.5	20.0	2600	0.018	10000	0.6	5.0	5.0	—	EEUFS0J472()	200	500
	5100	12.5	25.0	3190	0.015	10000	0.6	5.0	5.0	—	EEUFS0J512()	200	500
	5600	12.5	25.0	3190	0.015	10000	0.6	5.0	5.0	—	EEUFS0J562()	200	500
	6200	12.5	30.0	3630	0.013	10000	0.8	5.0	—	—	EEUFS0J622L	100	—
	6800	12.5	30.0	3630	0.013	10000	0.8	5.0	—	—	EEUFS0J682L	100	—
	7500	12.5	35.0	3750	0.012	10000	0.8	5.0	—	—	EEUFS0J752L	100	—
		16.0	20.0	3300	0.017	10000	0.8	7.5	7.5	—	EEUFS0J752S()	100	250
	8200	12.5	35.0	3750	0.012	10000	0.8	5.0	—	—	EEUFS0J822L	100	—
		16.0	20.0	3300	0.017	10000	0.8	7.5	7.5	—	EEUFS0J822S()	100	250
	9100	16.0	25.0	3820	0.014	10000	0.8	7.5	7.5	—	EEUFS0J912()	100	250
10000	16.0	25.0	3820	0.014	10000	0.8	7.5	7.5	—	EEUFS0J103()	100	250	
10	180	5.0	11.0	280	0.300	5000	0.5	2.0	5.0	2.5	EEUFS1A181()	200	2000
	330	6.3	11.2	455	0.130	5000	0.5	2.5	5.0	2.5	EEUFS1A331()	200	2000
	820	8.0	11.5	950	0.056	6000	0.6	3.5	5.0	—	EEUFS1A821()	200	1000
	1000	10.0	12.5	1290	0.043	6000	0.6	5.0	5.0	—	EEUFS1A102()	200	500
	1200	8.0	15.0	1240	0.041	8000	0.6	3.5	5.0	—	EEUFS1A122L()	200	1000
		10.0	12.5	1290	0.043	6000	0.6	5.0	5.0	—	EEUFS1A122()	200	500
	1800	8.0	20.0	1560	0.030	9000	0.6	3.5	5.0	—	EEUFS1A182L()	200	1000
		10.0	16.0	1790	0.028	8000	0.6	5.0	5.0	—	EEUFS1A182()	200	500
	2000	10.0	20.0	2180	0.020	10000	0.6	5.0	5.0	—	EEUFS1A202()	200	500
	2200	10.0	20.0	2180	0.020	10000	0.6	5.0	5.0	—	EEUFS1A222()	200	500
	2700	10.0	25.0	2470	0.018	10000	0.6	5.0	5.0	—	EEUFS1A272L()	200	500
	3600	12.5	20.0	2600	0.018	10000	0.6	5.0	5.0	—	EEUFS1A362()	200	500
	4700	12.5	25.0	3190	0.015	10000	0.6	5.0	5.0	—	EEUFS1A472()	200	500
	5100	12.5	30.0	3630	0.013	10000	0.8	5.0	—	—	EEUFS1A512L	100	—
	5600	12.5	30.0	3630	0.013	10000	0.8	5.0	—	—	EEUFS1A562L	100	—
		16.0	20.0	3300	0.017	10000	0.8	7.5	7.5	—	EEUFS1A562S()	100	250
7500	12.5	35.0	3750	0.012	10000	0.8	5.0	—	—	EEUFS1A752L	100	—	
8200	16.0	25.0	3820	0.014	10000	0.8	7.5	7.5	—	EEUFS1A822()	100	250	

*1: Ripple current (100 kHz / +105 °C)

*2: Impedance (100 kHz / +20 °C)

• When requesting taped product, please put the letter "B" or "H" between the "()".

Lead wire pitch *B=5 mm, 7.5 mm, H=2.5 mm.

• Please refer to the page of "Taping dimensions".

Characteristics list

Rated voltage (V)	Capacitance (±20 %) (μF)	Case size (mm)		Specification			Lead length (mm)				Part No.	Min. Packaging Q'ty (PCS)	
		øD	L	Ripple current* ¹ (mA rms)	Impe-dance* ² (Ω)	Endu-rance (h)	Lead dia. (ød)	Lead space				Straight leads	Taping
								Straight	Taping *B	Taping *H			
16	120	5.0	11.0	280	0.300	5000	0.5	2.0	5.0	2.5	EEUFS1C121()	200	2000
	510	8.0	11.5	950	0.056	6000	0.6	3.5	5.0	—	EEUFS1C511()	200	1000
	820	8.0	15.0	1240	0.041	8000	0.6	3.5	5.0	—	EEUFS1C821L()	200	1000
		10.0	12.5	1290	0.043	6000	0.6	5.0	5.0	—	EEUFS1C821()	200	500
	1200	8.0	20.0	1560	0.030	9000	0.6	3.5	5.0	—	EEUFS1C122L()	200	1000
		10.0	16.0	1790	0.028	8000	0.6	5.0	5.0	—	EEUFS1C122()	200	500
	1800	10.0	20.0	2180	0.020	10000	0.6	5.0	5.0	—	EEUFS1C182()	200	500
	2200	10.0	25.0	2470	0.018	10000	0.6	5.0	5.0	—	EEUFS1C222L()	200	500
	2400	12.5	20.0	2600	0.018	10000	0.6	5.0	5.0	—	EEUFS1C242()	200	500
	3300	12.5	25.0	3190	0.015	10000	0.6	5.0	5.0	—	EEUFS1C332()	200	500
	3600	12.5	30.0	3630	0.013	10000	0.8	5.0	—	—	EEUFS1C362L	100	—
	3900	12.5	30.0	3630	0.013	10000	0.8	5.0	—	—	EEUFS1C392L	100	—
	4700	16.0	20.0	3300	0.017	10000	0.8	7.5	7.5	—	EEUFS1C472S()	100	250
	5100	12.5	35.0	3750	0.012	10000	0.8	5.0	—	—	EEUFS1C512L	100	—
6200	16.0	25.0	3820	0.014	10000	0.8	7.5	7.5	—	EEUFS1C622()	100	250	
25	1200	10.0	20.0	2180	0.020	10000	0.6	5.0	5.0	—	EEUFS1E122()	200	500
	2200	12.5	25.0	3190	0.015	10000	0.6	5.0	5.0	—	EEUFS1E222()	200	500
	3300	12.5	35.0	3750	0.012	10000	0.8	5.0	—	—	EEUFS1E332L	100	—
	3900	16.0	25.0	3820	0.014	10000	0.8	7.5	7.5	—	EEUFS1E392()	100	250
35	330	8.0	15.0	1240	0.041	8000	0.6	3.5	5.0	—	EEUFS1V331L()	200	1000
	820	10.0	20.0	2180	0.020	10000	0.6	5.0	5.0	—	EEUFS1V821()	200	500
	1000	10.0	25.0	2470	0.018	10000	0.6	5.0	5.0	—	EEUFS1V102L()	200	500
	1500	12.5	25.0	3190	0.015	10000	0.6	5.0	5.0	—	EEUFS1V152()	200	500
	1800	16.0	20.0	3300	0.017	10000	0.8	7.5	7.5	—	EEUFS1V182S()	100	250
	2700	16.0	25.0	3820	0.014	10000	0.8	7.5	7.5	—	EEUFS1V272()	100	250
50	27	5.0	11.0	250	0.340	5000	0.5	2.0	5.0	2.5	EEUFS1H270()	200	2000
	150	8.0	15.0	1140	0.045	8000	0.6	3.5	5.0	—	EEUFS1H151L()	200	1000
	220	8.0	20.0	1430	0.033	9000	0.6	3.5	5.0	—	EEUFS1H221L()	200	1000
	330	10.0	20.0	1890	0.023	10000	0.6	5.0	5.0	—	EEUFS1H331()	200	500
	390	10.0	25.0	2150	0.022	10000	0.6	5.0	5.0	—	EEUFS1H391L()	200	500
	680	12.5	25.0	2660	0.018	10000	0.6	5.0	5.0	—	EEUFS1H681()	200	500
	820	12.5	30.0	3160	0.016	10000	0.8	5.0	—	—	EEUFS1H821L	100	—
	1000	12.5	35.0	3270	0.014	10000	0.8	5.0	—	—	EEUFS1H102L	100	—
	1200	16.0	25.0	3320	0.016	10000	0.8	7.5	7.5	—	EEUFS1H122()	100	250
63	27	5.0	11.0	175	0.510	5000	0.5	2.0	5.0	2.5	EEUFS1J270()	200	2000
	120	8.0	15.0	741	0.068	8000	0.6	3.5	5.0	—	EEUFS1J121L()	200	1000
		10.0	12.5	761	0.063	6000	0.6	5.0	5.0	—	EEUFS1J121()	200	500
	180	8.0	20.0	930	0.050	9000	0.6	3.5	5.0	—	EEUFS1J181L()	200	1000
		10.0	16.0	1073	0.045	8000	0.6	5.0	5.0	—	EEUFS1J181()	200	500
	330	10.0	25.0	1500	0.033	10000	0.6	5.0	5.0	—	EEUFS1J331L()	200	500
	390	12.5	20.0	1582	0.033	10000	0.6	5.0	5.0	—	EEUFS1J391()	200	500
	560	12.5	25.0	1995	0.027	10000	0.6	5.0	5.0	—	EEUFS1J561()	200	500
	680	16.0	20.0	2153	0.029	10000	0.8	7.5	7.5	—	EEUFS1J681S()	100	250
	820	12.5	35.0	2780	0.021	10000	0.8	5.0	—	—	EEUFS1J821L	100	—
1000	16.0	25.0	2988	0.024	10000	0.8	7.5	7.5	—	EEUFS1J102()	100	250	

*1: Ripple current (100 kHz / +105 °C)

*2: Impedance (100 kHz / +20 °C)

• When requesting taped product, please put the letter "B" or "H" between the "()".

Lead wire pitch *B=5 mm, 7.5 mm, H=2.5 mm.

• Please refer to the page of "Taping dimensions".

Characteristics list

Rated voltage (V)	Capacitance (±20 %) (μF)	Case size (mm)		Specification			Lead length (mm)			Part No.	Min. Packaging Q'ty (PCS)	
		øD	L	Ripple current* ¹ (mA rms)	Impe-dance* ² (Ω)	Endu-rance (h)	Lead dia. (ød)	Lead space			Straight leads	Taping
								Straight	Taping *B			
80	47	8.0	11.5	490	0.160	6000	0.6	3.5	5.0	EEUFS1K470()	200	1000
	56	8.0	11.5	490	0.160	6000	0.6	3.5	5.0	EEUFS1K560()	200	1000
	68	8.0	15.0	590	0.112	8000	0.6	3.5	5.0	EEUFS1K680()	200	1000
	82	8.0	15.0	590	0.112	8000	0.6	3.5	5.0	EEUFS1K820()	200	1000
	100	8.0	20.0	810	0.096	9000	0.6	3.5	5.0	EEUFS1K101L()	200	1000
		10.0	12.5	600	0.112	6000	0.6	5.0	5.0	EEUFS1K101()	200	500
	120	8.0	20.0	810	0.096	9000	0.6	3.5	5.0	EEUFS1K121L()	200	1000
	150	10.0	16.0	930	0.072	8000	0.6	5.0	5.0	EEUFS1K151()	200	500
	180	10.0	20.0	1120	0.054	10000	0.6	5.0	5.0	EEUFS1K181()	200	500
	220	10.0	20.0	1120	0.054	10000	0.6	5.0	5.0	EEUFS1K221()	200	500
		10.0	25.0	1200	0.044	10000	0.6	5.0	5.0	EEUFS1K221L()	200	500
	270	10.0	25.0	1200	0.044	10000	0.6	5.0	5.0	EEUFS1K271L()	200	500
		12.5	20.0	1400	0.043	10000	0.6	5.0	5.0	EEUFS1K271()	200	500
	390	12.5	25.0	1800	0.034	10000	0.6	5.0	5.0	EEUFS1K391()	200	500
	470	12.5	30.0	2200	0.030	10000	0.8	5.0	—	EEUFS1K471L()	100	—
		16.0	20.0	1450	0.032	10000	0.8	7.5	7.5	EEUFS1K471S()	100	250
560	12.5	35.0	2380	0.023	10000	0.8	5.0	—	EEUFS1K561L()	100	—	
680	16.0	25.0	2500	0.025	10000	0.8	7.5	7.5	EEUFS1K681()	100	250	
100	27	8.0	11.5	490	0.160	6000	0.6	3.5	5.0	EEUFS2A270()	200	1000
	33	8.0	11.5	490	0.160	6000	0.6	3.5	5.0	EEUFS2A330()	200	1000
	39	8.0	15.0	590	0.112	8000	0.6	3.5	5.0	EEUFS2A390()	200	1000
	47	8.0	15.0	590	0.112	8000	0.6	3.5	5.0	EEUFS2A470L()	200	1000
		10.0	12.5	600	0.112	6000	0.6	5.0	5.0	EEUFS2A470()	200	500
	56	8.0	20.0	810	0.096	9000	0.6	3.5	5.0	EEUFS2A560L()	200	1000
	68	8.0	20.0	810	0.096	9000	0.6	3.5	5.0	EEUFS2A680L()	200	1000
		10.0	16.0	930	0.072	8000	0.6	5.0	5.0	EEUFS2A680()	200	500
	120	10.0	20.0	1120	0.054	10000	0.6	5.0	5.0	EEUFS2A121()	200	500
		10.0	25.0	1200	0.044	10000	0.6	5.0	5.0	EEUFS2A121L()	200	500
	150	10.0	25.0	1200	0.044	10000	0.6	5.0	5.0	EEUFS2A151L()	200	500
		12.5	20.0	1400	0.043	10000	0.6	5.0	5.0	EEUFS2A151()	200	500
	180	12.5	25.0	1800	0.034	10000	0.6	5.0	5.0	EEUFS2A181()	200	500
	220	12.5	25.0	1800	0.034	10000	0.6	5.0	5.0	EEUFS2A221()	200	500
	270	12.5	30.0	2200	0.030	10000	0.8	5.0	—	EEUFS2A271L()	100	—
		16.0	20.0	1450	0.032	10000	0.8	7.5	7.5	EEUFS2A271S()	100	250
330	12.5	35.0	2380	0.023	10000	0.8	5.0	—	EEUFS2A331L()	100	—	
390	16.0	25.0	2500	0.025	10000	0.8	7.5	7.5	EEUFS2A391()	100	250	

*1: Ripple current (100 kHz / +105 °C)

*2: Impedance (100 kHz / +20 °C)

• When requesting taped product, please put the letter "B" between the "()".

Lead wire pitch *B=5 mm, 7.5 mm.

• Please refer to the page of "Taping dimensions".

Radial Lead Type

FP-A series



Features

- Endurance : 105 °C 4000 h to 5000 h
- High ripple current (2 to 2.5 times as high as FC series)
- Large capacitance (Up to 60 % larger than FC series)
- AEC-Q200 compliant
- RoHS compliant

Country of origin

- Malaysia

Specifications

Category temp. range	-55 °C to +105 °C		
Rated voltage range	25 V to 35 V		
Capacitance range	510 µF to 2000 µF		
Capacitance tolerance	±20 % (120 Hz / +20°C)		
Leakage current	$I \leq 0.01 CV (\mu A)$ After 2 minutes		
Dissipation factor (tan δ)	Rated voltage (V)	25	35
	Dissipation factor (tan δ)	0.14	0.12
(120 Hz / +20°C)			
Endurance	For capacitance value $\geq 1000 \mu F$, add 0.02 per every 1000 µF.		
	After following life test with DC voltage and +105 °C±2 °C ripple current value applied (The sum of DC and ripple peak voltage shall not exceed the rated working voltage)when the capacitors are restored to 20 °C, the capacitors shall meet the limits specified bellow.		
	Duration ø10 : 4000 h, ø12.5 : 5000 h		
	Capacitance change	Within ±30 % of the initial value	
	Dissipation factor (tan δ)	≤ 300 % of the initial limit	
Shelf life	DC leakage current	Within the initial limit	
	After storage for 1000 h at +105 °C±2 °C with no voltage applied and then being stabilized at +20 °C, capacitors shall meet the limits specified in endurance. (With voltage treatment)		

Frequency correction factor for ripple current

Cap. (µF) \ Freq. (Hz)	120	1 k	10 k	100 k to
510 to 1000	0.65	0.75	0.95	1.00
1200 to 2000	0.75	0.80	1.00	1.00

Dimensions

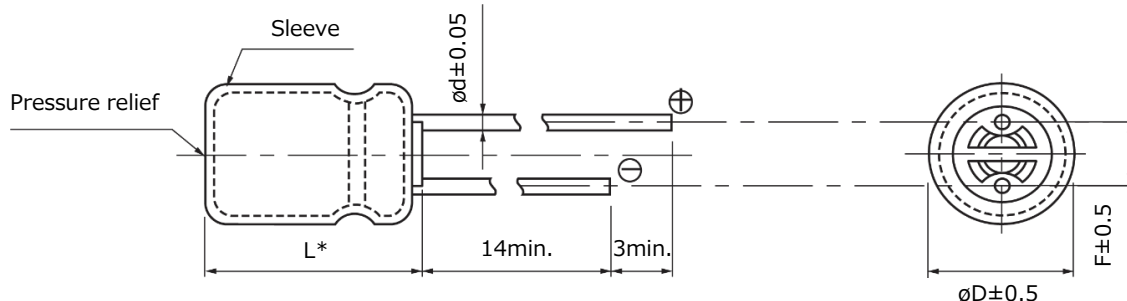

* $L \leq 16 : L \pm 1.5$
 $L \geq 20 : L \pm 2.0$

Unit : mm

øD	10.0	12.5
L	16 to 20	20 to 25
ød	0.6	0.6
F	5.0	5.0

Case size/ Impedance/ Ripple current

R. voltage Case size (mm) (ϕ D×L)	25 V to 35 V		
	ESR (Ω) (100 kHz)		Ripple current (mA rms) (100 kHz)
	+20 °C	-10 °C	+105 °C
10 × 16	0.068	0.136	2500
10 × 20	0.052	0.104	3000
12.5 × 20	0.038	0.076	3250
12.5 × 25	0.030	0.060	4000

Characteristics list

Rated voltage (V)	Capacitance ($\pm 20\%$) (μ F)	Case size (mm)		Specification			Lead length (mm)			Part No.	Min. Packaging Q'ty (PCS)	
		ϕ D	L	Ripple current ^{*1} (mA rms)	ESR ^{*2} (Ω)	Endu- rance (h)	Lead dia. (ϕ)	Lead space			Straight leads	Taping
								Straight	Taping *B			
25	680	10.0	16.0	2500	0.068	4000	0.6	5.0	5.0	EEUFP1E681()	200	500
	1000	10.0	20.0	3000	0.052	4000	0.6	5.0	5.0	EEUFP1E102()	200	500
	1500	12.5	20.0	3250	0.038	5000	0.6	5.0	5.0	EEUFP1E152()	200	500
	2000	12.5	25.0	4000	0.030	5000	0.6	5.0	5.0	EEUFP1E202()	200	500
35	510	10.0	16.0	2500	0.068	4000	0.6	5.0	5.0	EEUFP1V511()	200	500
	750	10.0	20.0	3000	0.052	4000	0.6	5.0	5.0	EEUFP1V751()	200	500
	1000	12.5	20.0	3250	0.038	5000	0.6	5.0	5.0	EEUFP1V102()	200	500
	1300	12.5	25.0	4000	0.030	5000	0.6	5.0	5.0	EEUFP1V132()	200	500

*1: Ripple current (100 kHz / +105 °C)

*2: ESR (100 kHz / +20 °C)

- When requesting taped product, please put the letter "B". Lead wire pitch *B=5 mm.
- Please refer to the page of "Taping dimensions".

Radial Lead Type

ED-A series

*Propose EE series for New design



Features

- Endurance : 105 °C 8000 h to 10000 h
- High ripple current (at high frequency)
- Including low profile products (20 mm height)
- RoHS compliant

Specifications

Category temp. range	-25 °C to +105 °C							
Rated voltage range	160 V to 450 V							
Capacitance range	10 µF to 330 µF							
Capacitance tolerance	±20 % (120 Hz / +20°C)							
Leakage current	$I \leq 0.06 CV + 10$ (µA) After 2 minutes application of rated working voltage at +20 °C							
Dissipation factor (tan δ)	Please see the attached characteristics list							
Characteristics at low temperature	Rated voltage (V)	160	200	250	350	400	450	(Impedance ratio at 120 Hz)
	Z(-25 °C) / Z(+20 °C)	3	3	3	6	6	6	
Endurance	After following life test with DC voltage and +105 °C±2 °C ripple current value applied (The sum of DC and ripple peak voltage shall not exceed the rated working voltage) when the capacitors are restored to 20 °C, the capacitors shall meet the limits specified bellow.							
	Duration							
	ø10 : 8000 h							
	ø12.5 to ø18 : 10000 h							
	Capacitance change	Within ±20 % of the initial value						
	Dissipation factor (tan δ)	≤ 200 % of the initial limit						
	DC leakage current	Within the initial limit						
Shelf life	After storage for 1000 h at +105 °C±2 °C with no voltage applied and then being stabilized at +20 °C, capacitors shall meet the limits specified in endurance. (With voltage treatment)							

Frequency correction factor for ripple current

Freq. (Hz) Cap. (µF)	50	120	300	1 k	10 k	100 k to
10 to 82	0.30	0.40	0.55	0.70	0.90	1.00
100 to 330	0.35	0.45	0.60	0.75	0.90	1.00

Dimensions

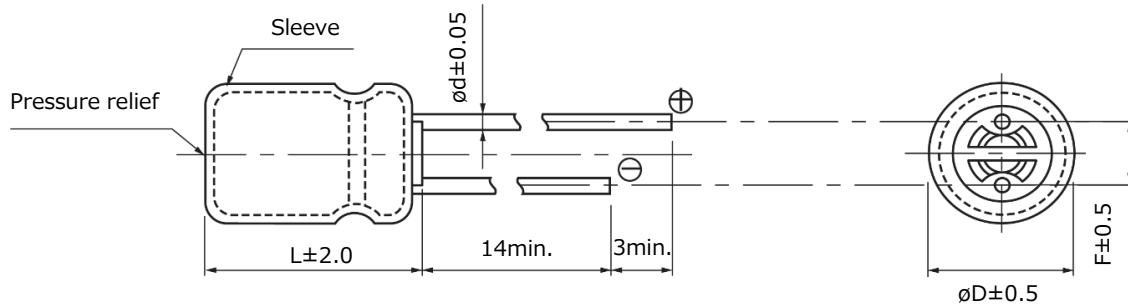

	Unit : mm			
øD	10.0	12.5	16.0	18.0
ød	0.6	0.6	0.8	0.8
F	5.0	5.0	7.5	7.5

Characteristics list

Endurance : 105 °C 8000 h / ø10, 105 °C 10000 h / ø12.5 to ø18

Rated voltage (V)	Capacitance (±20 %) (µF)	Case size (mm)		Specification			Lead length (mm)			Part No.	Min. Packaging Q'ty (PCS)		
		øD	L	Ripple current*1 (mA rms)	tan δ*2	Endurance (h)	Lead dia. (ød)	Lead space			Straight leads	Taping	
								Straight	Taping *B				
160	22	10.0	20.0	500	0.15	8000	0.6	5.0	5.0	EEUED2C220()	200	500	
	33	10.0	20.0	580	0.15	8000	0.6	5.0	5.0	EEUED2C330()	200	500	
	47	10.0	20.0	750	0.15	8000	0.6	5.0	5.0	EEUED2C470()	200	500	
	68	12.5	20.0	950	0.15	10000	0.6	5.0	5.0	EEUED2C680()	200	500	
	82	12.5	25.0	1060	0.15	10000	0.6	5.0	5.0	EEUED2C820()	200	500	
	100	100	12.5	25.0	1170	0.15	10000	0.6	5.0	5.0	EEUED2C101()	200	500
			16.0	20.0	1280	0.15	10000	0.8	7.5	7.5	EEUED2C101S()	100	250
	150	150	16.0	25.0	1400	0.15	10000	0.8	7.5	7.5	EEUED2C151()	100	250
			18.0	20.0	1400	0.15	10000	0.8	7.5	7.5	EEUED2C151S()	100	250
	220	220	16.0	31.5	1700	0.15	10000	0.8	7.5	—	EEUED2C221	100	—
18.0			25.0	1500	0.15	10000	0.8	7.5	7.5	EEUED2C221S()	100	250	
330	330	18.0	31.5	2000	0.15	10000	0.8	7.5	—	EEUED2C331	50	—	
200	22	10.0	20.0	600	0.15	8000	0.6	5.0	5.0	EEUED2D220()	200	500	
	33	10.0	20.0	650	0.15	8000	0.6	5.0	5.0	EEUED2D330()	200	500	
	47	12.5	20.0	790	0.15	10000	0.6	5.0	5.0	EEUED2D470()	200	500	
	68	68	12.5	25.0	950	0.15	10000	0.6	5.0	5.0	EEUED2D680()	200	500
			16.0	20.0	1000	0.15	10000	0.8	7.5	7.5	EEUED2D680S()	100	250
	82	16.0	20.0	1100	0.15	10000	0.8	7.5	7.5	EEUED2D820S()	100	250	
	100	100	16.0	25.0	1300	0.15	10000	0.8	7.5	7.5	EEUED2D101()	100	250
			18.0	20.0	1280	0.15	10000	0.8	7.5	7.5	EEUED2D101S()	100	250
	150	150	16.0	25.0	1400	0.15	10000	0.8	7.5	7.5	EEUED2D151()	100	250
	220	220	18.0	31.5	2000	0.15	10000	0.8	7.5	—	EEUED2D221	50	—
330	330	18.0	40.0	2400	0.15	10000	0.8	7.5	—	EEUED2D331	50	—	
250	22	10.0	20.0	560	0.15	8000	0.6	5.0	5.0	EEUED2E220()	200	500	
	33	12.5	20.0	710	0.15	10000	0.6	5.0	5.0	EEUED2E330()	200	500	
	47	47	12.5	25.0	920	0.15	10000	0.6	5.0	5.0	EEUED2E470()	200	500
			16.0	20.0	990	0.15	10000	0.8	7.5	7.5	EEUED2E470S()	100	250
	68	16.0	20.0	1000	0.15	10000	0.8	7.5	7.5	EEUED2E680S()	100	250	
	82	82	16.0	25.0	1200	0.15	10000	0.8	7.5	7.5	EEUED2E820()	100	250
			18.0	20.0	1200	0.15	10000	0.8	7.5	7.5	EEUED2E820S()	100	250
	100	100	16.0	31.5	1500	0.15	10000	0.8	7.5	—	EEUED2E101	100	—
			18.0	25.0	1500	0.15	10000	0.8	7.5	7.5	EEUED2E101S()	100	250
	150	150	18.0	31.5	1800	0.15	10000	0.8	7.5	—	EEUED2E151	50	—
220	220	18.0	40.0	2100	0.15	10000	0.8	7.5	—	EEUED2E221	50	—	
350	10	10.0	20.0	350	0.20	8000	0.6	5.0	5.0	EEUED2V100()	200	500	
	22	12.5	20.0	480	0.20	10000	0.6	5.0	5.0	EEUED2V220()	200	500	
	33	16.0	20.0	640	0.20	10000	0.8	7.5	7.5	EEUED2V330S()	100	250	
	47	47	16.0	25.0	800	0.20	10000	0.8	7.5	7.5	EEUED2V470()	100	250
			18.0	20.0	800	0.20	10000	0.8	7.5	7.5	EEUED2V470S()	100	250
	68	68	16.0	31.5	1100	0.20	10000	0.8	7.5	—	EEUED2V680	100	—
			18.0	25.0	1000	0.20	10000	0.8	7.5	7.5	EEUED2V680S()	100	250
	82	18.0	25.0	1100	0.20	10000	0.8	7.5	7.5	EEUED2V820S()	100	250	
100	18.0	31.5	1200	0.20	10000	0.8	7.5	—	EEUED2V101	50	—		

*1: Ripple current (100 kHz / +105 °C)

*2: tan δ (120 Hz / +20 °C)

- When requesting taped product, please put the letter "B". Lead wire pitch *B=5 mm, 7.5 mm.
- Please refer to the page of "Taping dimensions".

Characteristics list

Endurance : 105 °C 8000 h / ϕ 10, 105 °C 10000 h / ϕ 12.5 to ϕ 18

Rated voltage (V)	Capacitance ($\pm 20\%$) (μ F)	Case size (mm)		Specification			Lead length (mm)			Part No.	Min. Packaging Q'ty (PCS)	
		ϕ D	L	Ripple current* ¹ (mA rms)	tan δ * ²	Endurance (h)	Lead dia. (ϕ)	Lead space			Straight leads	Taping
								Straight	Taping *B			
400	10	10.0	20.0	300	0.24	8000	0.6	5.0	5.0	EEUED2G100()	200	500
	15	12.5	20.0	410	0.24	10000	0.6	5.0	5.0	EEUED2G150()	200	500
	22	12.5	25.0	500	0.24	10000	0.6	5.0	5.0	EEUED2G220()	200	500
		16.0	20.0	600	0.24	10000	0.8	7.5	7.5	EEUED2G220S()	100	250
	33	16.0	20.0	730	0.24	10000	0.8	7.5	7.5	EEUED2G330S()	100	250
	47	16.0	25.0	840	0.24	10000	0.8	7.5	7.5	EEUED2G470()	100	250
		18.0	20.0	840	0.24	10000	0.8	7.5	7.5	EEUED2G470S()	100	250
	68	18.0	31.5	1200	0.24	10000	0.8	7.5	—	EEUED2G680	50	—
82	18.0	40.0	1500	0.24	10000	0.8	7.5	—	EEUED2G820	50	—	
450	10	12.5	20.0	350	0.24	10000	0.6	5.0	5.0	EEUED2W100()	200	500
	15	12.5	25.0	560	0.24	10000	0.6	5.0	5.0	EEUED2W150()	200	500
	22	16.0	20.0	680	0.24	10000	0.8	7.5	7.5	EEUED2W220S()	100	250
	33	16.0	31.5	850	0.24	10000	0.8	7.5	—	EEUED2W330	100	—
		18.0	25.0	850	0.24	10000	0.8	7.5	7.5	EEUED2W330S()	100	250
	47	18.0	31.5	1000	0.24	10000	0.8	7.5	—	EEUED2W470	50	—
68	18.0	40.0	1300	0.24	10000	0.8	7.5	—	EEUED2W680	50	—	

*1: Ripple current (100 kHz / +105 °C)

*2: tan δ (120 Hz / +20 °C)

- When requesting taped product, please put the letter "B". Lead wire pitch *B=5 mm, 7.5 mm.
- Please refer to the page of "Taping dimensions".

Radial Lead Type

GA-A series



Features

- Endurance : 105 °C 1000 h
- RoHS compliant

Specifications

Category temp. range	-55 °C to +105 °C		
Rated voltage range	10 V to 50 V		
Capacitance range	1.5 µF to 220 µF		
Capacitance tolerance	±20 % (120 Hz / +20°C)		
Leakage current	I ≤ 0.01 CV or 3 (µA) After 2 minutes (Whichever is greater)		
Dissipation factor (tan δ)	Please see the attached characteristics list		
Endurance	After following life test with DC voltage and +105 °C±2 °C ripple current value applied (The sum of DC and ripple peak voltage shall not exceed the rated working voltage), for 1000 hours, when the capacitors are restored to 20 °C, the capacitors shall meet the limits specified bellow.		
	Capacitance change	Within ±20 % of the initial value	
	Dissipation factor (tan δ)	≤ 200 % of the initial limit	
	DC leakage current	Within the initial limit	
Shelf life	After storage for 1000 h at +105 °C±2 °C with no voltage applied and then being stabilized at +20 °C, capacitors shall meet the limits specified in endurance. (With voltage treatment)		

Frequency correction factor for ripple current

Freq. (Hz)	60	120	1 k	10 k	100 k to
Cap. (µF)					
1.5 to 220	0.85	1.00	1.30	1.40	1.55

Dimensions

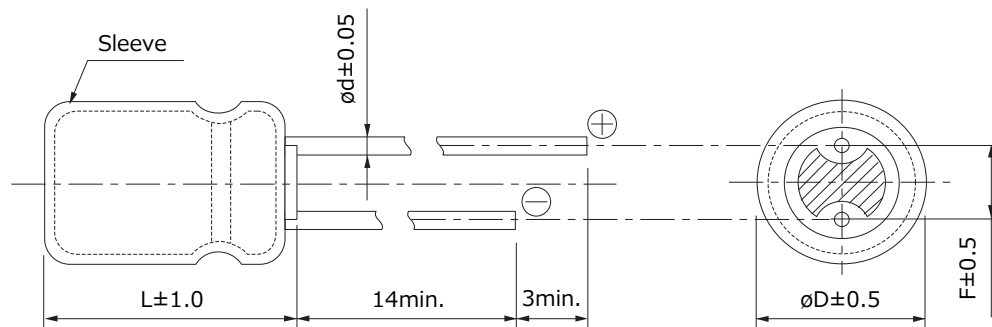

Unit : mm

øD	4.0	5.0	6.3	8.0
ød	0.45	0.45	0.45	0.45
F	1.5	2.0	2.5	2.5

Characteristics list

Endurance : 105 °C 1000 h

Rated voltage (V)	Capacitance (±20 %) (μF)	Case size (mm)		Specification			Lead length (mm)			Part No.	Min. Packaging Q'ty (PCS)		
		øD	L	Ripple current* ¹ (mA rms)	tan δ* ²	Endurance (h)	Lead dia. (ød)	Lead space			Straight leads	Taping	
								Straight	Taping *B				Taping *H
10	22	4.0	7.0	30	0.22	1000	0.45	1.5	5.0	2.5	EEAGA1A220()	200	2000
	33	5.0	7.0	50	0.22	1000	0.45	2.0	5.0	2.5	EEAGA1A330()	200	2000
	47	6.3	7.0	65	0.22	1000	0.45	2.5	5.0	2.5	EEAGA1A470()	200	2000
	68	6.3	7.0	75	0.22	1000	0.45	2.5	5.0	2.5	EEAGA1A680()	200	2000
	100	6.3	7.0	110	0.22	1000	0.45	2.5	5.0	2.5	EEAGA1A101()	200	2000
	220	8.0	7.0	160	0.22	1000	0.45	2.5	5.0	2.5	EEAGA1A221()	200	1000
16	10	4.0	7.0	30	0.18	1000	0.45	1.5	5.0	2.5	EEAGA1C100()	200	2000
	15	4.0	7.0	33	0.18	1000	0.45	1.5	5.0	2.5	EEAGA1C150()	200	2000
	22	5.0	7.0	50	0.18	1000	0.45	2.0	5.0	2.5	EEAGA1C220()	200	2000
	33	6.3	7.0	65	0.18	1000	0.45	2.5	5.0	2.5	EEAGA1C330()	200	2000
	47	6.3	7.0	77	0.18	1000	0.45	2.5	5.0	2.5	EEAGA1C470()	200	2000
	100	8.0	7.0	120	0.18	1000	0.45	2.5	5.0	2.5	EEAGA1C101()	200	1000
25	10	4.0	7.0	33	0.16	1000	0.45	1.5	5.0	2.5	EEAGA1E100()	200	2000
	15	5.0	7.0	45	0.16	1000	0.45	2.0	5.0	2.5	EEAGA1E150()	200	2000
	22	5.0	7.0	50	0.16	1000	0.45	2.0	5.0	2.5	EEAGA1E220()	200	2000
	33	6.3	7.0	75	0.16	1000	0.45	2.5	5.0	2.5	EEAGA1E330()	200	2000
	68	8.0	7.0	100	0.16	1000	0.45	2.5	5.0	2.5	EEAGA1E680()	200	1000
35	6.8	4.0	7.0	33	0.13	1000	0.45	1.5	5.0	2.5	EEAGA1V6R8()	200	2000
	10	5.0	7.0	35	0.13	1000	0.45	2.0	5.0	2.5	EEAGA1V100()	200	2000
	15	6.3	7.0	50	0.13	1000	0.45	2.5	5.0	2.5	EEAGA1V150()	200	2000
	22	6.3	7.0	70	0.13	1000	0.45	2.5	5.0	2.5	EEAGA1V220()	200	2000
	47	8.0	7.0	96	0.13	1000	0.45	2.5	5.0	2.5	EEAGA1V470()	200	1000
50	1.5	4.0	7.0	16	0.10	1000	0.45	1.5	5.0	2.5	EEAGA1H1R5()	200	2000
	2.2	4.0	7.0	18	0.10	1000	0.45	1.5	5.0	2.5	EEAGA1H2R2()	200	2000
	3.3	4.0	7.0	22	0.10	1000	0.45	1.5	5.0	2.5	EEAGA1H3R3()	200	2000
	4.7	4.0	7.0	26	0.10	1000	0.45	1.5	5.0	2.5	EEAGA1H4R7()	200	2000
	6.8	5.0	7.0	35	0.10	1000	0.45	2.0	5.0	2.5	EEAGA1H6R8()	200	2000
	10	6.3	7.0	39	0.10	1000	0.45	2.5	5.0	2.5	EEAGA1H100()	200	2000
	15	6.3	7.0	55	0.10	1000	0.45	2.5	5.0	2.5	EEAGA1H150()	200	2000
	22	8.0	7.0	70	0.10	1000	0.45	2.5	5.0	2.5	EEAGA1H220()	200	1000
	33	8.0	7.0	91	0.10	1000	0.45	2.5	5.0	2.5	EEAGA1H330()	200	1000

*1: Ripple current (120 Hz / +105 °C)

*2: tan δ (120 Hz / +20 °C)

• When requesting taped product, please put the letter "B" or "H" between the "()".

Lead wire pitch *B=5 mm, H=2.5 mm. Suffix "BQ" for ø8×7, 5 mm pitch products

• Please refer to the page of "Taping dimensions".

Radial Lead Type

KA-A series

Low Profile

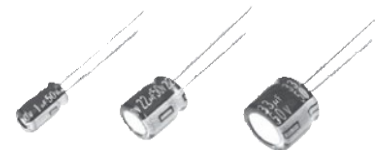

Features

- Endurance : 85 °C 1000 h
- 7 mm height
- RoHS compliant

Specifications

Category temp. range	-40 °C to +85 °C	
Rated voltage range	4 V to 50 V	
Capacitance range	2.2 µF to 470 µF	
Capacitance tolerance	±20 % (120 Hz / +20°C)	
Leakage current	I ≤ 0.01 CV or 3 (µA) After 2 minutes (Whichever is greater)	
Dissipation factor (tan δ)	Please see the attached characteristics list	
Endurance	After applying rated working voltage for 1000 h at +85 °C±2 °C when the capacitors are restored to 20 °C, capacitors shall meet the following limits.	
	Capacitance change	Within ±20 % of the initial value
	Dissipation factor (tan δ)	≤ 200 % of the initial limit
	DC leakage current	Within the initial limit
Shelf life	After storage for 1000 h at +85 °C±2 °C with no voltage applied and then being stabilized at +20 °C, capacitors shall meet the limits specified in endurance. (With voltage treatment)	

Frequency correction factor for ripple current

Freq. (Hz)	50, 60	120	1 k	10 k to
Cap. (µF)				
2.2 to 470	0.70	1.00	1.30	1.70

Dimensions

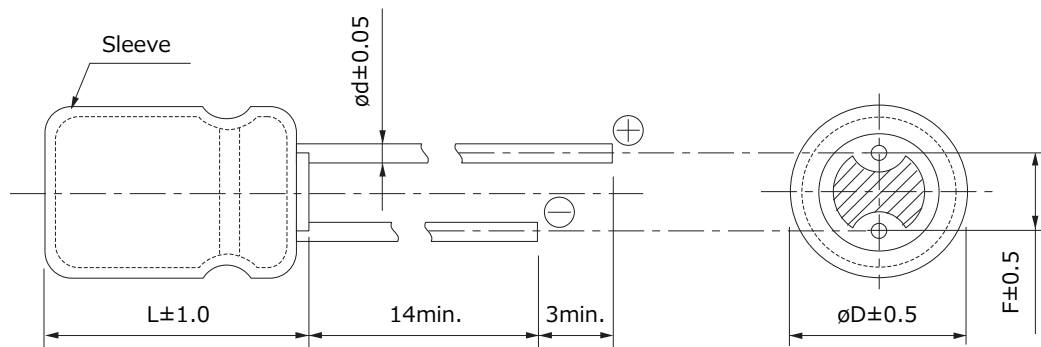

Unit : mm

øD	4.0	5.0	6.3	8.0
ød	0.45	0.45	0.45	0.45
F	1.5	2.0	2.5	2.5

Characteristics list

Endurance : 85 °C 1000 h

Rated voltage (V)	Capacitance (±20 %) (μF)	Case size (mm)		Specification		Lead length (mm)			Part No.	Min. Packaging Qty (PCS)		
		øD	L	Ripple current* ¹ (mA rms)	tan δ* ²	Lead dia. (ød)	Lead space			Straight leads	Taping	
							Straight	Taping *B				Taping *i
4	47	4.0	7.0	34	0.35	0.45	1.5	5.0	2.5	ECEA0GKA470()	200	2000
	100	5.0	7.0	61	0.35	0.45	2.0	5.0	2.5	ECEA0GKA101()	200	2000
	220	6.3	7.0	82	0.35	0.45	2.5	5.0	2.5	ECEA0GKA221()	200	2000
	330	8.0	7.0	110	0.35	0.45	2.5	—	2.5	ECEA0GKA331()	200	1000
		8.0	7.0	110	0.35	0.45	—	5.0	—	ECEA0GKA331Q	—	1000
	470	8.0	7.0	140	0.35	0.45	2.5	—	2.5	ECEA0GKA471()	200	1000
8.0		7.0	140	0.35	0.45	—	5.0	—	ECEA0GKA471Q	—	1000	
6.3	47	4.0	7.0	46	0.24	0.45	1.5	5.0	2.5	ECEA0JKA470()	200	2000
	100	5.0	7.0	71	0.24	0.45	2.0	5.0	2.5	ECEA0JKA101()	200	2000
	220	6.3	7.0	103	0.24	0.45	2.5	5.0	2.5	ECEA0JKA221()	200	2000
	330	8.0	7.0	130	0.24	0.45	2.5	—	2.5	ECEA0JKA331()	200	1000
		8.0	7.0	130	0.24	0.45	—	5.0	—	ECEA0JKA331Q	—	1000
10	33	4.0	7.0	43	0.20	0.45	1.5	5.0	2.5	ECEA1AKA330()	200	2000
	100	6.3	7.0	80	0.20	0.45	2.5	5.0	2.5	ECEA1AKA101()	200	2000
	220	8.0	7.0	120	0.20	0.45	2.5	—	2.5	ECEA1AKA221()	200	1000
		8.0	7.0	120	0.20	0.45	—	5.0	—	ECEA1AKA221Q	—	1000
16	10	4.0	7.0	28	0.16	0.45	1.5	5.0	2.5	ECEA1CKA100()	200	2000
	22	4.0	7.0	39	0.16	0.45	1.5	5.0	2.5	ECEA1CKA220()	200	2000
	33	5.0	7.0	60	0.16	0.45	2.0	5.0	2.5	ECEA1CKA330()	200	2000
	47	5.0	7.0	70	0.16	0.45	2.0	5.0	2.5	ECEA1CKA470()	200	2000
	100	6.3	7.0	91	0.16	0.45	2.5	5.0	2.5	ECEA1CKA101()	200	2000
25	10	4.0	7.0	28	0.14	0.45	1.5	5.0	2.5	ECEA1EKA100()	200	2000
	22	5.0	7.0	55	0.14	0.45	2.0	5.0	2.5	ECEA1EKA220()	200	2000
	33	6.3	7.0	65	0.14	0.45	2.5	5.0	2.5	ECEA1EKA330()	200	2000
	47	6.3	7.0	70	0.14	0.45	2.5	5.0	2.5	ECEA1EKA470()	200	2000
8.0		7.0	85	0.12	0.45	2.5	—	2.5	ECEA1VKA470()	200	1000	
35	10	5.0	7.0	30	0.12	0.45	2.0	5.0	2.5	ECEA1VKA100()	200	2000
	22	6.3	7.0	60	0.12	0.45	2.5	5.0	2.5	ECEA1VKA220()	200	2000
	33	6.3	7.0	65	0.12	0.45	2.5	5.0	2.5	ECEA1VKA330()	200	2000
	47	8.0	7.0	85	0.12	0.45	2.5	—	2.5	ECEA1VKA470()	200	1000
		8.0	7.0	85	0.12	0.45	—	5.0	—	ECEA1VKA470Q	—	1000
50	2.2	4.0	7.0	16	0.10	0.45	1.5	5.0	2.5	ECEA1HKA2R2()	200	2000
	3.3	4.0	7.0	18	0.10	0.45	1.5	5.0	2.5	ECEA1HKA3R3()	200	2000
	4.7	4.0	7.0	23	0.10	0.45	1.5	5.0	2.5	ECEA1HKA4R7()	200	2000
	10	5.0	7.0	35	0.10	0.45	2.0	5.0	2.5	ECEA1HKA100()	200	2000
	22	6.3	7.0	60	0.10	0.45	2.5	5.0	2.5	ECEA1HKA220()	200	2000
		8.0	7.0	75	0.10	0.45	2.5	—	2.5	ECEA1HKA330()	200	1000
33	8.0	7.0	75	0.10	0.45	—	5.0	—	ECEA1HKA330Q	—	1000	

*1: Ripple current (120 Hz / +85 °C)

*2: tan δ (120 Hz / +20 °C)

- When requesting taped product, please put the letter "B" or "i" between the "()".
Lead wire pitch *B=5 mm, i=2.5 mm.
- Please refer to the page of "Taping dimensions".

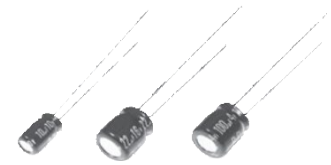

Radial Lead Type KA-A (Bi-polar) series

Features

- Endurance : 85 °C 1000 h
- 7 mm height
- RoHS compliant

Specifications

Category temp. range	-40 °C to +85 °C	
Rated voltage range	4 V to 50 V	
Capacitance range	2.2 µF to 100 µF	
Capacitance tolerance	±20 % (120 Hz / +20°C)	
Leakage current	$I \leq 0.05 CV$ or 10 (µA) After 2 minutes (Whichever is greater)	
Dissipation factor (tan δ)	Please see the attached characteristics list	
Endurance	After 1000 h application of DC working voltage (500 h for each polarity) at +85 °C±2 °C, when the capacitors are restored to 20 °C, the capacitors shall meet the following limits.	
	Capacitance change	Within ±20 % of the initial value
	Dissipation factor (tan δ)	≤ 200 % of the initial limit
	DC leakage current	Within the initial limit
Shelf life	After storage for 1000 h at +85 °C±2 °C with no voltage applied and then being stabilized at +20 °C, capacitors shall meet the limits specified in endurance. (With voltage treatment)	

Frequency correction factor for ripple current

Freq. (Hz)	50, 60	120	1 k	10 k to
Cap. (µF)				
2.2 to 100	0.70	1.00	1.30	1.70

Dimensions

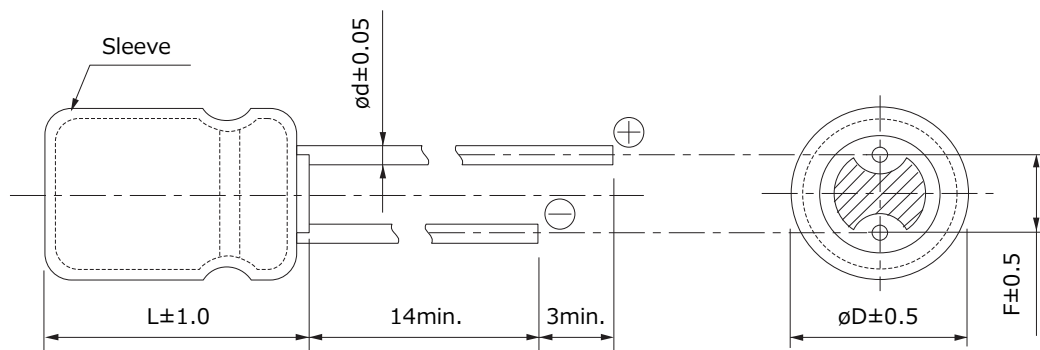

	Unit : mm		
øD	4.0	5.0	6.3
ød	0.45	0.45	0.45
F	1.5	2.0	2.5

Characteristics list

Endurance : 85 °C 1000 h (500 h for each polarity)

Rated voltage (V)	Capacitance (±20 %) (μF)	Case size (mm)		Specification		Lead length (mm)			Part No.	Min. Packaging Q'ty (PCS)		
		øD	L	Ripple current* ¹ (mA rms)	tan δ* ²	Lead dia. (ød)	Lead space			Straight leads	Taping	
							Straight	Taping *B				Taping *i
4	100	6.3	7.0	61	0.35	0.45	2.5	5.0	2.5	ECEA0GKN101()	200	2000
6.3	22	5.0	7.0	29	0.24	0.45	2.0	5.0	2.5	ECEA0JKN220()	200	2000
	33	5.0	7.0	38	0.24	0.45	2.0	5.0	2.5	ECEA0JKN330()	200	2000
	47	6.3	7.0	46	0.24	0.45	2.5	5.0	2.5	ECEA0JKN470()	200	2000
	10	4.0	7.0	25	0.20	0.45	1.5	5.0	2.5	ECEA1AKN100()	200	2000
10	22	5.0	7.0	35	0.20	0.45	2.0	5.0	2.5	ECEA1AKN220()	200	2000
	33	6.3	7.0	43	0.20	0.45	2.5	5.0	2.5	ECEA1AKN330()	200	2000
	47	6.3	7.0	65	0.20	0.45	2.5	5.0	2.5	ECEA1AKN470()	200	2000
16	4.7	4.0	7.0	20	0.16	0.45	1.5	5.0	2.5	ECEA1CKN4R7()	200	2000
	10	5.0	7.0	25	0.16	0.45	2.0	5.0	2.5	ECEA1CKN100()	200	2000
	22	6.3	7.0	39	0.16	0.45	2.5	5.0	2.5	ECEA1CKN220()	200	2000
	33	6.3	7.0	60	0.16	0.45	2.5	5.0	2.5	ECEA1CKN330()	200	2000
25	3.3	4.0	7.0	16	0.16	0.45	1.5	5.0	2.5	ECEA1EKN3R3()	200	2000
	4.7	5.0	7.0	21	0.16	0.45	2.0	5.0	2.5	ECEA1EKN4R7()	200	2000
	10	6.3	7.0	28	0.16	0.45	2.5	5.0	2.5	ECEA1EKN100()	200	2000
	22	6.3	7.0	55	0.16	0.45	2.5	5.0	2.5	ECEA1EKN220()	200	2000
35	2.2	4.0	7.0	12	0.14	0.45	1.5	5.0	2.5	ECEA1VKN2R2()	200	2000
	3.3	5.0	7.0	16	0.14	0.45	2.0	5.0	2.5	ECEA1VKN3R3()	200	2000
	4.7	5.0	7.0	22	0.14	0.45	2.0	5.0	2.5	ECEA1VKN4R7()	200	2000
	10	6.3	7.0	30	0.14	0.45	2.5	5.0	2.5	ECEA1VKN100()	200	2000
50	2.2	5.0	7.0	16	0.12	0.45	2.0	5.0	2.5	ECEA1HKN2R2()	200	2000
	3.3	5.0	7.0	16	0.12	0.45	2.0	5.0	2.5	ECEA1HKN3R3()	200	2000
	4.7	6.3	7.0	23	0.12	0.45	2.5	5.0	2.5	ECEA1HKN4R7()	200	2000

*1: Ripple current (120 Hz / +85 °C)

*2: tan δ (120 Hz / +20 °C)

- When requesting taped product, please put the letter "B" or "i" between the "()".
Lead wire pitch *B=5 mm, i=2.5 mm.
- Please refer to the page of "Taping dimensions".

Radial Lead Type

KS-A series

Low Profile

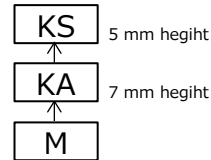

Features

- Endurance : 85 °C 1000 h
- 5 mm height
- RoHS compliant

Specifications

Category temp. range	-40 °C to +85 °C	
Rated voltage range	4 V to 50 V	
Capacitance range	2.2 μF to 330 μF	
Capacitance tolerance	±20 % (120 Hz / +20°C)	
Leakage current	I ≤ 0.01 CV or 3 (μA) After 2 minutes (Whichever is greater)	
Dissipation factor (tan δ)	Please see the attached characteristics list	
Endurance	After applying rated working voltage for 1000 h at +85 °C±2 °C when the capacitors are restored to 20 °C, capacitors shall meet the following limits.	
	Capacitance change	Within ±20 % of the initial value (4 V : ±30 %)
	Dissipation factor (tan δ)	≤ 200 % of the initial limit
	DC leakage current	Within the initial limit
Shelf life	After storage for 1000 h at +85 °C±2 °C with no voltage applied and then being stabilized at +20 °C, capacitors shall meet the limits specified in endurance. (With voltage treatment)	

Frequency correction factor for ripple current

Freq. (Hz)	50, 60	120	1 k	10 k to
Cap. (μF)				
2.2 to 330	0.70	1.00	1.30	1.70

Dimensions

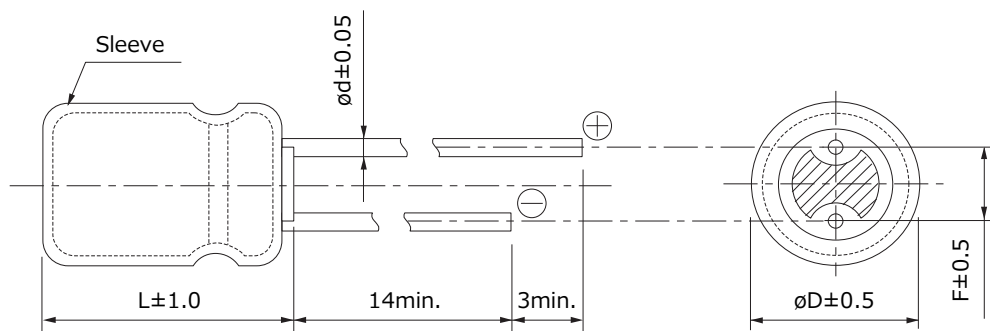

	Unit : mm			
øD	4.0	5.0	6.3	8.0
ød	0.45	0.45	0.45	0.45
F	1.5	2.0	2.5	2.5

Characteristics list

Endurance : 85 °C 1000 h

Rated voltage (V)	Capacitance (±20 %) (μF)	Case size (mm)		Specification		Lead length (mm)			Part No.	Min. Packaging Q'ty (PCS)			
		øD	L	Ripple current* ¹ (mA rms)	tan δ* ²	Lead dia. (ød)	Lead space			Straight leads	Taping		
							Straight	Taping *B				Taping *i	
4	33	4.0	5.0	26	0.35	0.45	1.5	5.0	2.5	ECEA0GKS330()	200	2000	
	47	4.0	5.0	34	0.35	0.45	1.5	5.0	2.5	ECEA0GKS470()	200	2000	
	100	5.0	5.0	61	0.35	0.45	2.0	5.0	2.5	ECEA0GKS101()	200	2000	
	220	6.3	5.0	82	0.35	0.45	2.5	5.0	2.5	ECEA0GKS221()	200	2000	
6.3	22	4.0	5.0	29	0.24	0.45	1.5	5.0	2.5	ECEA0JKS220()	200	2000	
	33	5.0	5.0	38	0.24	0.45	2.0	5.0	2.5	ECEA0JKS330()	200	2000	
	47	5.0	5.0	46	0.24	0.45	2.0	5.0	2.5	ECEA0JKS470()	200	2000	
	100	6.3	5.0	71	0.24	0.45	2.5	5.0	2.5	ECEA0JKS101()	200	2000	
	330	8.0	5.0	130	0.24	0.45	2.5	—	2.5	ECEA0JKS331()	200	1000	
		8.0	5.0	130	0.24	0.45	—	5.0	—	ECEA0JKS331Q	—	1000	
10	22	5.0	5.0	35	0.20	0.45	2.0	5.0	2.5	ECEA1AKS220()	200	2000	
	33	5.0	5.0	43	0.20	0.45	2.0	5.0	2.5	ECEA1AKS330()	200	2000	
	47	6.3	5.0	65	0.20	0.45	2.5	5.0	2.5	ECEA1AKS470()	200	2000	
	100	6.3	5.0	80	0.20	0.45	2.5	5.0	2.5	ECEA1AKS101()	200	2000	
	220	8.0	5.0	120	0.20	0.45	2.5	—	2.5	ECEA1AKS221()	200	1000	
			8.0	5.0	120	0.20	0.45	—	5.0	—	ECEA1AKS221Q	—	1000
16	10	4.0	5.0	28	0.16	0.45	1.5	5.0	2.5	ECEA1CKS100()	200	2000	
	22	5.0	5.0	39	0.16	0.45	2.0	5.0	2.5	ECEA1CKS220()	200	2000	
	33	6.3	5.0	60	0.16	0.45	2.5	5.0	2.5	ECEA1CKS330()	200	2000	
	47	6.3	5.0	70	0.16	0.45	2.5	5.0	2.5	ECEA1CKS470()	200	2000	
	100	8.0	5.0	91	0.16	0.45	2.5	—	2.5	ECEA1CKS101()	200	1000	
			8.0	5.0	91	0.16	0.45	—	5.0	—	ECEA1CKS101Q	—	1000
25	4.7	4.0	5.0	22	0.14	0.45	1.5	5.0	2.5	ECEA1EKS4R7()	200	2000	
	10	5.0	5.0	28	0.14	0.45	2.0	5.0	2.5	ECEA1EKS100()	200	2000	
	22	6.3	5.0	55	0.14	0.45	2.5	5.0	2.5	ECEA1EKS220()	200	2000	
	33	6.3	5.0	65	0.14	0.45	2.5	5.0	2.5	ECEA1EKS330()	200	2000	
	100	8.0	5.0	85	0.14	0.45	2.5	—	2.5	ECEA1EKS101()	200	1000	
			8.0	5.0	85	0.14	0.45	—	5.0	—	ECEA1EKS101Q	—	1000
35	3.3	4.0	5.0	16	0.12	0.45	1.5	5.0	2.5	ECEA1VKS3R3()	200	2000	
	4.7	4.0	5.0	22	0.12	0.45	1.5	5.0	2.5	ECEA1VKS4R7()	200	2000	
	10	5.0	5.0	30	0.12	0.45	2.0	5.0	2.5	ECEA1VKS100()	200	2000	
	22	6.3	5.0	60	0.12	0.45	2.5	5.0	2.5	ECEA1VKS220()	200	2000	
	33	8.0	5.0	65	0.12	0.45	2.5	—	2.5	ECEA1VKS330()	200	1000	
			8.0	5.0	65	0.12	0.45	—	5.0	—	ECEA1VKS330Q	—	1000
	47	8.0	5.0	85	0.12	0.45	2.5	—	2.5	ECEA1VKS470()	200	1000	
			8.0	5.0	85	0.12	0.45	—	5.0	—	ECEA1VKS470Q	—	1000
50	2.2	4.0	5.0	16	0.10	0.45	1.5	5.0	2.5	ECEA1HKS2R2()	200	2000	
	3.3	4.0	5.0	16	0.10	0.45	1.5	5.0	2.5	ECEA1HKS3R3()	200	2000	
	4.7	5.0	5.0	23	0.10	0.45	2.0	5.0	2.5	ECEA1HKS4R7()	200	2000	
	10	6.3	5.0	35	0.10	0.45	2.5	5.0	2.5	ECEA1HKS100()	200	2000	
	22	8.0	5.0	60	0.10	0.45	2.5	—	2.5	ECEA1HKS220()	200	1000	
			8.0	5.0	60	0.10	0.45	—	5.0	—	ECEA1HKS220Q	—	1000

*1: Ripple current (120 Hz / +85 °C)

*2: tan δ (120 Hz / +20 °C)

• When requesting taped product, please put the letter "B" or "i" between the "()".

Lead wire pitch *B=5 mm, i=2.5 mm.

• Please refer to the page of "Taping dimensions".

Radial Lead Type KS-A (Bi-polar) series

Low Profile

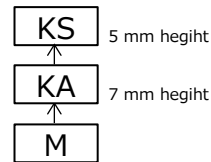

Features

- Endurance : 85 °C 1000 h
- 5 mm height
- RoHS compliant

Specifications

Category temp. range	-40 °C to +85 °C	
Rated voltage range	6.3 V to 50 V	
Capacitance range	2.2 μF to 47 μF	
Capacitance tolerance	±20 % (120 Hz / +20°C)	
Leakage current	$I \leq 0.05 CV$ or 10 (μA) After 2 minutes (Whichever is greater)	
Dissipation factor (tan δ)	Please see the attached characteristics list	
Endurance	After 1000 h application of DC working voltage (500 h for each polarity) at +85 °C±2 °C, when the capacitors are restored to 20 °C, the capacitors shall meet the following limits.	
	Capacitance change	Within ±20 % of the initial value
	Dissipation factor (tan δ)	≤ 200 % of the initial limit
	DC leakage current	Within the initial limit
Shelf life	After storage for 1000 h at +85 °C±2 °C with no voltage applied and then being stabilized at +20 °C, capacitors shall meet the limits specified in endurance. (With voltage treatment)	

Frequency correction factor for ripple current

Freq. (Hz)	50, 60	120	1 k	10 k to
Cap. (μF)				
2.2 to 47	0.70	1.00	1.30	1.70

Dimensions

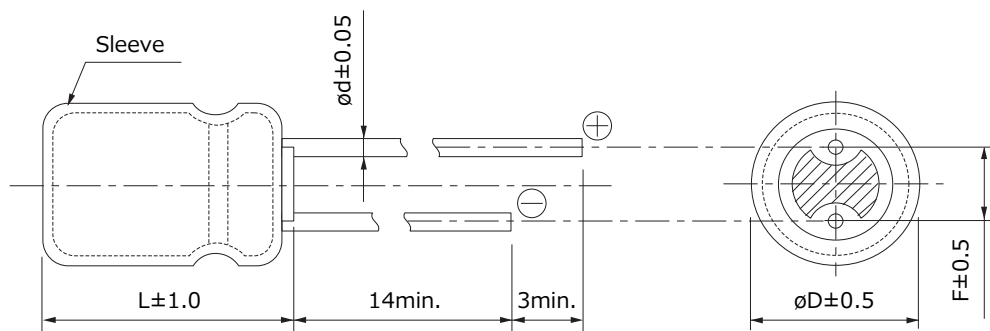

	Unit : mm		
øD	4	5	6.3
ød	0.45	0.45	0.45
F	1.5	2.0	2.5

Characteristics list

Endurance : 85 °C 1000 h (500 h for each polarity)

Rated voltage (V)	Capacitance (±20 %) (μF)	Case size (mm)		Specification		Lead length (mm)			Part No.	Min. Packaging Q'ty (PCS)		
		øD	L	Ripple current* ¹ (mA rms)	tan δ* ²	Lead dia. (ød)	Lead space			Straight leads	Taping	
							Straight	Taping *B				Taping *i
6.3	22	5.0	5.0	29	0.24	0.45	2.0	5.0	2.5	ECEA0JSN220()	200	2000
	33	6.3	5.0	38	0.24	0.45	2.5	5.0	2.5	ECEA0JSN330()	200	2000
	47	6.3	5.0	46	0.24	0.45	2.5	5.0	2.5	ECEA0JSN470()	200	2000
10	10	4.0	5.0	25	0.20	0.45	1.5	5.0	2.5	ECEA1ASN100()	200	2000
	22	6.3	5.0	35	0.20	0.45	2.5	5.0	2.5	ECEA1ASN220()	200	2000
	33	6.3	5.0	43	0.20	0.45	2.5	5.0	2.5	ECEA1ASN330()	200	2000
16	4.7	4.0	5.0	20	0.20	0.45	1.5	5.0	2.5	ECEA1CSN4R7()	200	2000
	10	5.0	5.0	25	0.20	0.45	2.0	5.0	2.5	ECEA1CSN100()	200	2000
	22	6.3	5.0	39	0.20	0.45	2.5	5.0	2.5	ECEA1CSN220()	200	2000
25	3.3	5.0	5.0	18	0.20	0.45	2.0	5.0	2.5	ECEA1ESN3R3()	200	2000
	4.7	5.0	5.0	21	0.20	0.45	2.0	5.0	2.5	ECEA1ESN4R7()	200	2000
	10	6.3	5.0	28	0.20	0.45	2.5	5.0	2.5	ECEA1ESN100()	200	2000
35	2.2	4.0	5.0	12	0.20	0.45	1.5	5.0	2.5	ECEA1VSN2R2()	200	2000
50	2.2	5.0	5.0	16	0.20	0.45	2.0	5.0	2.5	ECEA1HSN2R2()	200	2000

*1: Ripple current (120 Hz / +85 °C)

*2: tan δ (120 Hz / +20 °C)

• When requesting taped product, please put the letter "B" or "i" between the "()".

Lead wire pitch *B=5 mm, i=2.5 mm.

• Please refer to the page of "Taping dimensions".



This Series is no longer available for purchase in the country of Japan.



Radial Lead Type

FC-A series

Features

- Endurance : 105 °C 1000 h to 5000 h
- Low impedance
- AEC-Q200 compliant
- RoHS compliant

Specifications

Category temp. range	-55 °C to +105 °C									
Rated voltage range	6.3 V to 100 V									
Capacitance range	2.2 μF to 15000 μF									
Capacitance tolerance	±20 % (120 Hz / +20°C)									
Leakage current	I ≤ 0.01 CV or 3 (μA) After 2 minutes (Whichever is greater)									
Dissipation factor (tan δ)	Rated voltage (V)	6.3	10	16	25	35	50	63	100	(120 Hz
	Dissipation factor (tan δ)	0.22	0.19	0.16	0.14	0.12	0.10	0.08	0.07	/+20°C)
Endurance	For capacitance value ≥ 1000 μF, add 0.02 per every 1000 μF.									
	After following life test with DC voltage and +105 °C±2 °C ripple current value applied (The sum of DC and ripple peak voltage shall not exceed the rated working voltage)when the capacitors are restored to 20 °C, the capacitors shall meet the limits specified bellow.									
	Duration ø4 to ø6.3 : 1000 h, ø8 : 2000 h, ø10 : 3000 h, ø12.5 to ø18 : 5000 h									
	Capacitance change	Within ±20 % of the initial value								
	Dissipation factor (tan δ)	≤ 200 % of the initial limit								
Shelf life	After storage for 1000 h at +105 °C±2 °C with no voltage applied and then being stabilized at +20 °C, capacitors shall meet the limits specified in endurance.									
	(With voltage treatment)									

Frequency correction factor for ripple current

Cap. (μF) \ Freq. (Hz)	60	120	1 k	10 k	100 k
2.2 to 330	0.55	0.65	0.85	0.90	1.00
390 to 1000	0.70	0.75	0.90	0.95	1.00
1200 to 2200	0.75	0.80	0.90	0.95	1.00
2700 to 15000	0.80	0.85	0.95	1.00	1.00

Dimensions

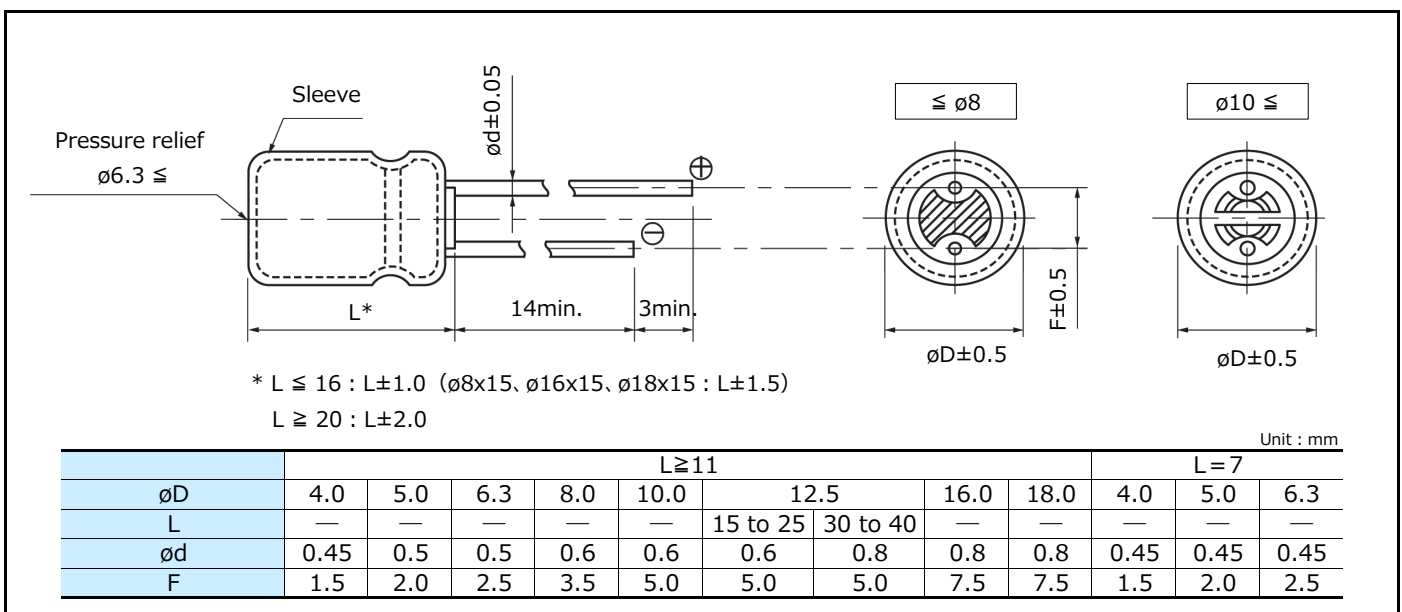

Case size/ Impedance/ Ripple current

R. voltage Case size (mm) (ϕ D×L)	6.3 V to 35 V			50 V			63 V			100 V		
	Impedance ^{*1} (Ω)		Ripple current ^{*1} (mA rms)	Impedance ^{*1} (Ω)		Ripple current ^{*1} (mA rms)	Impedance ^{*1} (Ω)		Ripple current ^{*1} (mA rms)	Impedance ^{*1} (Ω)		Ripple current ^{*1} (mA rms)
	+20°C	-10°C		+20°C	-10°C		+20°C	-10°C		+20°C	-10°C	
4 × 7	2.00	5.00	65	—	—	—	—	—	—	—	—	—
5 × 7	0.950	2.40	120	—	—	—	—	—	—	—	—	—
6.3 × 7	0.450	1.20	200	—	—	—	—	—	—	—	—	—
5 × 11	0.800	1.60	175	*2	*2	*2	2.00	4.00	145	4.10	8.20	80
6.3 × 11.2	0.350	0.700	290	0.600	1.20	260	1.00	2.00	240	1.80	3.60	114
8 × 11.5	0.117	0.234	555	0.234	0.468	485	0.342	0.684	405	0.680	1.36	260
8 × 15	0.085	0.170	730	0.155	0.310	635	0.230	0.460	535	0.450	0.900	340
8 × 20	0.065	0.130	995	0.120	0.240	860	0.178	0.356	690	0.330	0.660	455
10 × 12.5	0.090	0.180	755	0.162	0.324	615	0.256	0.512	535	0.530	1.060	306
10 × 16	0.068	0.136	1050	0.119	0.238	850	0.194	0.388	600	0.360	0.720	400
10 × 20	0.052	0.104	1220	0.090	0.180	1030	0.147	0.294	885	0.240	0.480	463
10 × 25	0.045	0.090	1440	0.082	0.164	1200	0.130	0.260	1050	0.210	0.420	599
10 × 30	0.035	0.070	1815	0.060	0.120	1610	0.090	0.180	1300	0.150	0.300	698
12.5 × 15	0.065	0.130	1205	0.110	0.220	1150	0.150	0.300	1020	0.230	0.460	511
12.5 × 20	0.038	0.076	1655	0.063	0.126	1480	0.085	0.170	1285	0.180	0.360	671
12.5 × 25	0.030	0.060	1945	0.050	0.100	1832	0.070	0.140	1720	0.110	0.220	807
12.5 × 30	0.025	0.050	2310	0.040	0.080	2215	0.055	0.110	2090	0.098	0.196	937
12.5 × 35	0.022	0.044	2510	0.034	0.068	2285	0.047	0.094	2265	0.087	0.174	1040
12.5 × 40	0.018	0.036	2655	0.030	0.060	2590	0.042	0.084	2560	0.072	0.144	1130
16 × 15	0.043	0.086	1690	0.080	0.160	1610	0.090	0.180	1410	0.140	0.280	793
16 × 20	0.029	0.058	2205	0.048	0.096	1835	0.059	0.118	1765	0.110	0.220	995
16 × 25	0.022	0.044	2555	0.034	0.068	2235	0.050	0.100	2160	0.089	0.178	1170
16 × 31.5	0.018	0.036	3010	0.028	0.056	2700	0.043	0.086	2670	0.062	0.124	1520
16 × 35.5	0.016	0.032	3150	0.025	0.050	2790	0.036	0.072	2770	0.053	0.106	1730
16 × 40	0.015	0.030	3360	0.023	0.046	2845	0.030	0.060	2825	0.047	0.094	1920
18 × 15	0.038	0.076	2000	0.068	0.136	1900	0.086	0.172	1690	0.120	0.240	917
18 × 20	0.028	0.056	2490	0.042	0.084	2420	0.055	0.110	2290	0.080	0.160	1230
18 × 25	0.020	0.040	2740	0.029	0.058	2610	0.043	0.086	2585	0.070	0.140	1420
18 × 31.5	0.016	0.032	3635	0.025	0.050	3000	0.032	0.064	2950	0.062	0.124	1600
18 × 35.5	0.015	0.030	3680	0.023	0.046	3100	0.030	0.060	3095	0.041	0.082	1770
18 × 40	0.014	0.028	3735	—	—	—	0.025	0.050	3205	0.036	0.072	2300

*1: 100 kHz

*2

Case size (mm) (ϕ D×L)	Capacitance (μ F)	Impedance (Ω) (100 kHz)		Ripple current (mA rms) (100 kHz)
		+20°C	-10°C	
5 × 11	2.2	1.80	3.60	45
	3.3	1.30	2.60	65
	4.7	1.30	2.60	95
	10	1.30	2.60	125
	12	1.30	2.60	135
	15	1.30	2.60	145
	18	1.30	2.60	155
	22	1.30	2.60	155

Characteristics list

Endurance : 105 °C 1000 h / ϕ 4 to ϕ 6.3, 105 °C 2000 h / ϕ 8, 105 °C 3000 h / ϕ 10, 105 °C 5000 h / ϕ 12.5 to ϕ 18

Rated voltage (V)	Capacitance ($\pm 20\%$) (μ F)	Case size (mm)		Specification			Lead length (mm)				Part No.	Min. Packaging Q'ty (PCS)	
		ϕ D	L	Ripple current* ¹ (mA rms)	Impedance* ² (Ω)	Endurance (h)	Lead dia. (ϕ d)	Lead space				Straight leads	Taping
								Straight	Taping *B	Taping *H			
6.3	27	4.0	7.0	65	2.000	1000	0.45	1.5	5.0	2.5	EEAFC0J270()	200	2000
	56	5.0	7.0	120	0.950	1000	0.45	2.0	5.0	2.5	EEAFC0J560()	200	2000
	100	5.0	11.0	175	0.800	1000	0.50	2.0	5.0	2.5	EEUFC0J101()	200	2000
	120	6.3	7.0	200	0.450	1000	0.45	2.5	5.0	2.5	EEAFC0J121()	200	2000
	220	6.3	11.2	290	0.350	1000	0.50	2.5	5.0	2.5	EEUFC0J221()	200	2000
	270	6.3	11.2	290	0.350	1000	0.50	2.5	5.0	2.5	EEUFC0J271()	200	2000
	330	6.3	11.2	290	0.350	1000	0.50	2.5	5.0	2.5	EEUFC0J331S()	200	2000
	390	8.0	11.5	555	0.117	2000	0.60	3.5	5.0	—	EEUFC0J391()	200	1000
	470	8.0	11.5	555	0.117	2000	0.60	3.5	5.0	—	EEUFC0J471()	200	1000
	560	8.0	11.5	555	0.117	2000	0.60	3.5	5.0	—	EEUFC0J561()	200	1000
	820	8.0	15.0	730	0.085	2000	0.60	3.5	5.0	—	EEUFC0J821L()	200	1000
		10.0	12.5	755	0.090	3000	0.60	5.0	5.0	—	EEUFC0J821()	200	500
	1000	10.0	12.5	755	0.090	3000	0.60	5.0	5.0	—	EEUFC0J102()	200	500
	1200	8.0	20.0	995	0.065	2000	0.60	3.5	5.0	—	EEUFC0J122L()	200	1000
		10.0	16.0	1050	0.068	3000	0.60	5.0	5.0	—	EEUFC0J122()	200	500
	1500	10.0	20.0	1220	0.052	3000	0.60	5.0	5.0	—	EEUFC0J152()	200	500
		12.5	15.0	1205	0.065	5000	0.60	5.0	5.0	—	EEUFC0J152S()	200	500
	1800	10.0	25.0	1440	0.045	3000	0.60	5.0	5.0	—	EEUFC0J182()	200	500
	2200	10.0	25.0	1440	0.045	3000	0.60	5.0	5.0	—	EEUFC0J222()	200	500
		16.0	15.0	1690	0.043	5000	0.80	7.5	7.5	—	EEUFC0J222S()	100	250
	2700	10.0	30.0	1815	0.035	3000	0.60	5.0	—	—	EEUFC0J272L	100	—
		12.5	20.0	1655	0.038	5000	0.60	5.0	5.0	—	EEUFC0J272()	200	500
		16.0	15.0	1690	0.043	5000	0.80	7.5	7.5	—	EEUFC0J272S()	100	250
	3300	12.5	20.0	1655	0.038	5000	0.60	5.0	5.0	—	EEUFC0J332()	200	500
		18.0	15.0	2000	0.038	5000	0.80	7.5	7.5	—	EEUFC0J332S()	100	250
	3900	12.5	25.0	1945	0.030	5000	0.60	5.0	5.0	—	EEUFC0J392()	200	500
	4700	12.5	30.0	2310	0.025	5000	0.80	5.0	—	—	EEUFC0J472	100	—
		16.0	20.0	2205	0.029	5000	0.80	7.5	7.5	—	EEUFC0J472S()	100	250
	5600	12.5	35.0	2510	0.022	5000	0.80	5.0	—	—	EEUFC0J562L	100	—
		16.0	20.0	2205	0.029	5000	0.80	7.5	7.5	—	EEUFC0J562()	100	250
	6800	12.5	40.0	2655	0.018	5000	0.80	5.0	—	—	EEUFC0J682L	100	—
		16.0	25.0	2555	0.022	5000	0.80	7.5	7.5	—	EEUFC0J682()	100	250
		18.0	20.0	2490	0.028	5000	0.80	7.5	7.5	—	EEUFC0J682S()	100	250
8200	16.0	31.5	3010	0.018	5000	0.80	7.5	—	—	EEUFC0J822	100	—	
10000	16.0	35.5	3150	0.016	5000	0.80	7.5	—	—	EEUFC0J103	100	—	
	18.0	25.0	2740	0.020	5000	0.80	7.5	7.5	—	EEUFC0J103S()	100	250	
12000	16.0	40.0	3360	0.015	5000	0.80	7.5	—	—	EEUFC0J123L	100	—	
	18.0	31.5	3635	0.016	5000	0.80	7.5	—	—	EEUFC0J123	50	—	
15000	18.0	35.5	3680	0.015	5000	0.80	7.5	—	—	EEUFC0J153	50	—	

*1: Ripple current (100 kHz / +105 °C)

*2: Impedance (100 kHz / +20 °C)

• When requesting taped product, please put the letter "B" or "H" between the "()".

Lead wire pitch *B=5 mm, 7.5 mm, H=2.5 mm.

• Please refer to the page of "Taping dimensions".

Characteristics list

Endurance : 105 °C 1000 h / $\phi 4$ to $\phi 6.3$, 105 °C 2000 h / $\phi 8$, 105 °C 3000 h / $\phi 10$, 105 °C 5000 h / $\phi 12.5$ to $\phi 18$

Rated voltage (V)	Capacitance ($\pm 20\%$) (μF)	Case size (mm)		Specification			Lead length (mm)				Part No.	Min. Packaging Q'ty (PCS)	
		ϕD	L	Ripple current* ¹ (mA rms)	Impe-dance* ² (Ω)	Endu-rance (h)	Lead dia. (ϕd)	Lead space				Straight leads	Taping
								Straight	Taping *B	Taping *H			
10	22	4.0	7.0	65	2.000	1000	0.45	1.5	5.0	2.5	EEAFC1A220()	200	2000
	39	5.0	7.0	120	0.950	1000	0.45	2.0	5.0	2.5	EEAFC1A390()	200	2000
	82	5.0	11.0	175	0.800	1000	0.50	2.0	5.0	2.5	EEUFC1A820()	200	2000
		6.3	7.0	200	0.450	1000	0.45	2.5	5.0	2.5	EEAFC1A820()	200	2000
	100	5.0	11.0	175	0.800	1000	0.50	2.0	5.0	2.5	EEUFC1A101S()	200	2000
	150	6.3	11.2	290	0.350	1000	0.50	2.5	5.0	2.5	EEUFC1A151()	200	2000
	180	6.3	11.2	290	0.350	1000	0.50	2.5	5.0	2.5	EEUFC1A181()	200	2000
	220	6.3	11.2	290	0.350	1000	0.50	2.5	5.0	2.5	EEUFC1A221S()	200	2000
	330	8.0	11.5	555	0.117	2000	0.60	3.5	5.0	—	EEUFC1A331()	200	1000
	390	8.0	11.5	555	0.117	2000	0.60	3.5	5.0	—	EEUFC1A391()	200	1000
	470	8.0	11.5	555	0.117	2000	0.60	3.5	5.0	—	EEUFC1A471()	200	1000
	560	10.0	12.5	755	0.090	3000	0.60	5.0	5.0	—	EEUFC1A561()	200	500
	680	8.0	15.0	730	0.085	2000	0.60	3.5	5.0	—	EEUFC1A681L()	200	1000
		10.0	12.5	755	0.090	3000	0.60	5.0	5.0	—	EEUFC1A681()	200	500
	820	10.0	16.0	1050	0.068	3000	0.60	5.0	5.0	—	EEUFC1A821()	200	500
	1000	8.0	20.0	995	0.065	2000	0.60	3.5	5.0	—	EEUFC1A102L()	200	1000
		10.0	16.0	1050	0.068	3000	0.60	5.0	5.0	—	EEUFC1A102()	200	500
	1200	10.0	20.0	1220	0.052	3000	0.60	5.0	5.0	—	EEUFC1A122()	200	500
		12.5	15.0	1205	0.065	5000	0.60	5.0	5.0	—	EEUFC1A122S()	200	500
	1500	10.0	25.0	1440	0.045	3000	0.60	5.0	5.0	—	EEUFC1A152()	200	500
	1800	12.5	20.0	1655	0.038	5000	0.60	5.0	5.0	—	EEUFC1A182()	200	500
		16.0	15.0	1690	0.043	5000	0.80	7.5	7.5	—	EEUFC1A182S()	100	250
	2200	10.0	30.0	1815	0.035	3000	0.60	5.0	—	—	EEUFC1A222L	100	—
		12.5	20.0	1655	0.038	5000	0.60	5.0	5.0	—	EEUFC1A222()	200	500
	2700	12.5	25.0	1945	0.030	5000	0.60	5.0	5.0	—	EEUFC1A272()	200	500
		18.0	15.0	2000	0.038	5000	0.80	7.5	7.5	—	EEUFC1A272S()	100	250
	3300	12.5	30.0	2310	0.025	5000	0.80	5.0	—	—	EEUFC1A332	100	—
		16.0	20.0	2205	0.029	5000	0.80	7.5	7.5	—	EEUFC1A332S()	100	250
3900	12.5	35.0	2510	0.022	5000	0.80	5.0	—	—	EEUFC1A392L	100	—	
	16.0	20.0	2205	0.029	5000	0.80	7.5	7.5	—	EEUFC1A392()	100	250	
4700	12.5	40.0	2655	0.018	5000	0.80	5.0	—	—	EEUFC1A472L	100	—	
	16.0	25.0	2555	0.022	5000	0.80	7.5	7.5	—	EEUFC1A472()	100	250	
5600	16.0	25.0	2555	0.022	5000	0.80	7.5	7.5	—	EEUFC1A562()	100	250	
	18.0	20.0	2490	0.028	5000	0.80	7.5	7.5	—	EEUFC1A562S()	100	250	
6800	16.0	31.5	3010	0.018	5000	0.80	7.5	—	—	EEUFC1A682	100	—	
	18.0	25.0	2740	0.020	5000	0.80	7.5	7.5	—	EEUFC1A682S()	100	250	
8200	16.0	35.5	3150	0.016	5000	0.80	7.5	—	—	EEUFC1A822L	100	—	
	18.0	31.5	3635	0.016	5000	0.80	7.5	—	—	EEUFC1A822	50	—	
10000	18.0	35.5	3680	0.015	5000	0.80	7.5	—	—	EEUFC1A103	50	—	
12000	18.0	40.0	3735	0.014	5000	0.80	7.5	—	—	EEUFC1A123	50	—	

*1: Ripple current (100 kHz / +105 °C)

*2: Impedance (100 kHz / +20 °C)

• When requesting taped product, please put the letter "B" or "H" between the "()".

Lead wire pitch *B=5 mm, 7.5 mm, H=2.5 mm.

• Please refer to the page of "Taping dimensions".

Characteristics list

Endurance : 105 °C 1000 h / $\phi 4$ to $\phi 6.3$, 105 °C 2000 h / $\phi 8$, 105 °C 3000 h / $\phi 10$, 105 °C 5000 h / $\phi 12.5$ to $\phi 18$

Rated voltage (V)	Capacitance ($\pm 20\%$) (μF)	Case size (mm)		Specification			Lead length (mm)				Part No.	Min. Packaging Q'ty (PCS)	
		ϕD	L	Ripple current* ¹ (mA rms)	Impedance* ² (Ω)	Endurance (h)	Lead dia. (ϕ)	Lead space				Straight leads	Taping
								Straight	Taping *B	Taping *H			
16	15	4.0	7.0	65	2.000	1000	0.45	1.5	5.0	2.5	EEAFC1C150()	200	2000
	27	5.0	7.0	120	0.950	1000	0.45	2.0	5.0	2.5	EEAFC1C270()	200	2000
	47	5.0	11.0	175	0.800	1000	0.50	2.0	5.0	2.5	EEUFC1C470()	200	2000
	56	5.0	11.0	175	0.800	1000	0.50	2.0	5.0	2.5	EEUFC1C560()	200	2000
		6.3	7.0	200	0.450	1000	0.45	2.5	5.0	2.5	EEAFC1C560()	200	2000
	68	5.0	11.0	175	0.800	1000	0.50	2.0	5.0	2.5	EEUFC1C680()	200	2000
	100	6.3	11.2	290	0.350	1000	0.50	2.5	5.0	2.5	EEUFC1C101()	200	2000
	120	6.3	11.2	290	0.350	1000	0.50	2.5	5.0	2.5	EEUFC1C121()	200	2000
	220	8.0	11.5	555	0.117	2000	0.60	3.5	5.0	—	EEUFC1C221()	200	1000
	270	8.0	11.5	555	0.117	2000	0.60	3.5	5.0	—	EEUFC1C271()	200	1000
	330	8.0	11.5	555	0.117	2000	0.60	3.5	5.0	—	EEUFC1C331()	200	1000
	390	10.0	12.5	755	0.090	3000	0.60	5.0	5.0	—	EEUFC1C391()	200	500
	470	8.0	15.0	730	0.085	2000	0.60	3.5	5.0	—	EEUFC1C471L()	200	1000
		10.0	12.5	755	0.090	3000	0.60	5.0	5.0	—	EEUFC1C471()	200	500
	560	10.0	16.0	1050	0.068	3000	0.60	5.0	5.0	—	EEUFC1C561()	200	500
	680	8.0	20.0	995	0.065	2000	0.60	3.5	5.0	—	EEUFC1C681L()	200	1000
		10.0	16.0	1050	0.068	3000	0.60	5.0	5.0	—	EEUFC1C681()	200	500
	820	10.0	20.0	1220	0.052	3000	0.60	5.0	5.0	—	EEUFC1C821()	200	500
		12.5	15.0	1205	0.065	5000	0.60	5.0	5.0	—	EEUFC1C821S()	200	500
	1000	10.0	20.0	1220	0.052	3000	0.60	5.0	5.0	—	EEUFC1C102S()	200	500
		10.0	25.0	1440	0.045	3000	0.60	5.0	5.0	—	EEUFC1C102()	200	500
	1200	10.0	25.0	1440	0.045	3000	0.60	5.0	5.0	—	EEUFC1C122()	200	500
		16.0	15.0	1690	0.043	5000	0.80	7.5	7.5	—	EEUFC1C122S()	100	250
	1500	10.0	30.0	1815	0.035	3000	0.60	5.0	—	—	EEUFC1C152L	100	—
		12.5	20.0	1655	0.038	5000	0.60	5.0	5.0	—	EEUFC1C152()	200	500
		16.0	15.0	1690	0.043	5000	0.80	7.5	7.5	—	EEUFC1C152S()	100	250
	1800	12.5	25.0	1945	0.030	5000	0.60	5.0	5.0	—	EEUFC1C182()	200	500
		18.0	15.0	2000	0.038	5000	0.80	7.5	7.5	—	EEUFC1C182S()	100	250
	2200	12.5	25.0	1945	0.030	5000	0.60	5.0	5.0	—	EEUFC1C222()	200	500
		16.0	20.0	2205	0.029	5000	0.80	7.5	7.5	—	EEUFC1C222S()	100	250
	2700	12.5	30.0	2310	0.025	5000	0.80	5.0	—	—	EEUFC1C272L	100	—
		16.0	20.0	2205	0.029	5000	0.80	7.5	7.5	—	EEUFC1C272()	100	250
3300	12.5	35.0	2510	0.022	5000	0.80	5.0	—	—	EEUFC1C332	100	—	
	18.0	20.0	2490	0.028	5000	0.80	7.5	7.5	—	EEUFC1C332S()	100	250	
3900	16.0	25.0	2555	0.022	5000	0.80	7.5	7.5	—	EEUFC1C392()	100	250	
	18.0	20.0	2490	0.028	5000	0.80	7.5	7.5	—	EEUFC1C392S()	100	250	
4700	16.0	31.5	3010	0.018	5000	0.80	7.5	—	—	EEUFC1C472	100	—	
	18.0	25.0	2740	0.020	5000	0.80	7.5	7.5	—	EEUFC1C472S()	100	250	
5600	16.0	35.5	3150	0.016	5000	0.80	7.5	—	—	EEUFC1C562L	100	—	
	18.0	31.5	3635	0.016	5000	0.80	7.5	—	—	EEUFC1C562	50	—	
6800	16.0	40.0	3360	0.015	5000	0.80	7.5	—	—	EEUFC1C682	100	—	
8200	18.0	35.5	3680	0.015	5000	0.80	7.5	—	—	EEUFC1C822	50	—	

*1: Ripple current (100 kHz / +105 °C)

*2: Impedance (100 kHz / +20 °C)

• When requesting taped product, please put the letter "B" or "H" between the "()".

Lead wire pitch *B=5 mm, 7.5 mm, H=2.5 mm.

• Please refer to the page of "Taping dimensions".

Characteristics list

Endurance : 105 °C 1000 h / ϕ 4 to ϕ 6.3, 105 °C 2000 h / ϕ 8, 105 °C 3000 h / ϕ 10, 105 °C 5000 h / ϕ 12.5 to ϕ 18

Rated voltage (V)	Capacitance ($\pm 20\%$) (μ F)	Case size (mm)		Specification			Lead length (mm)			Part No.	Min. Packaging Q'ty (PCS)		
		ϕ D	L	Ripple current* ¹ (mA rms)	Impe-dance* ² (Ω)	Endu-rance (h)	Lead dia. (ϕ d)	Lead space			Straight leads	Taping	
								Straight	Taping *B				Taping *H
25	10	4.0	7.0	65	2.000	1000	0.45	1.5	5.0	2.5	EEAFC1E100()	200	2000
	22	5.0	7.0	120	0.950	1000	0.45	2.0	5.0	2.5	EEAFC1E220()	200	2000
	39	5.0	11.0	175	0.800	1000	0.50	2.0	5.0	2.5	EEUFC1E390()	200	2000
		6.3	7.0	200	0.450	1000	0.45	2.5	5.0	2.5	EEAFC1E390()	200	2000
	47	5.0	11.0	175	0.800	1000	0.50	2.0	5.0	2.5	EEUFC1E470()	200	2000
	82	6.3	11.2	290	0.350	1000	0.50	2.5	5.0	2.5	EEUFC1E820()	200	2000
	100	6.3	11.2	290	0.350	1000	0.50	2.5	5.0	2.5	EEUFC1E101S()	200	2000
	180	8.0	11.5	555	0.117	2000	0.60	3.5	5.0	—	EEUFC1E181()	200	1000
	220	8.0	11.5	555	0.117	2000	0.60	3.5	5.0	—	EEUFC1E221()	200	1000
	270	10.0	12.5	755	0.090	3000	0.60	5.0	5.0	—	EEUFC1E271()	200	500
	330	8.0	15.0	730	0.085	2000	0.60	3.5	5.0	—	EEUFC1E331L()	200	1000
		10.0	12.5	755	0.090	3000	0.60	5.0	5.0	—	EEUFC1E331()	200	500
	390	10.0	16.0	1050	0.068	3000	0.60	5.0	5.0	—	EEUFC1E391()	200	500
	470	8.0	20.0	995	0.065	2000	0.60	3.5	5.0	—	EEUFC1E471L()	200	1000
		10.0	16.0	1050	0.068	3000	0.60	5.0	5.0	—	EEUFC1E471()	200	500
	560	10.0	20.0	1220	0.052	3000	0.60	5.0	5.0	—	EEUFC1E561()	200	500
		12.5	15.0	1205	0.065	5000	0.60	5.0	5.0	—	EEUFC1E561S()	200	500
	680	10.0	20.0	1220	0.052	3000	0.60	5.0	5.0	—	EEUFC1E681()	200	500
	820	10.0	25.0	1440	0.045	3000	0.60	5.0	5.0	—	EEUFC1E821()	200	500
		12.5	20.0	1655	0.038	5000	0.60	5.0	5.0	—	EEUFC1E821S()	200	500
	1000	10.0	30.0	1815	0.035	3000	0.60	5.0	—	—	EEUFC1E102L	100	—
		12.5	20.0	1655	0.038	5000	0.60	5.0	5.0	—	EEUFC1E102()	200	500
		16.0	15.0	1690	0.043	5000	0.80	7.5	7.5	—	EEUFC1E102S()	100	250
	1200	12.5	25.0	1945	0.030	5000	0.60	5.0	5.0	—	EEUFC1E122()	200	500
		18.0	15.0	2000	0.038	5000	0.80	7.5	7.5	—	EEUFC1E122S()	100	250
	1500	12.5	25.0	1945	0.030	5000	0.60	5.0	5.0	—	EEUFC1E152()	200	500
		16.0	20.0	2205	0.029	5000	0.80	7.5	7.5	—	EEUFC1E152S()	100	250
	1800	12.5	30.0	2310	0.025	5000	0.80	5.0	—	—	EEUFC1E182L	100	—
		16.0	20.0	2205	0.029	5000	0.80	7.5	7.5	—	EEUFC1E182()	100	250
	2200	12.5	35.0	2510	0.022	5000	0.80	5.0	—	—	EEUFC1E222	100	—
18.0		20.0	2490	0.028	5000	0.80	7.5	7.5	—	EEUFC1E222S()	100	250	
2700	16.0	25.0	2555	0.022	5000	0.80	7.5	7.5	—	EEUFC1E272()	100	250	
3300	16.0	31.5	3010	0.018	5000	0.80	7.5	—	—	EEUFC1E332	100	—	
	18.0	25.0	2740	0.020	5000	0.80	7.5	7.5	—	EEUFC1E332S()	100	250	
3900	16.0	35.5	3150	0.016	5000	0.80	7.5	—	—	EEUFC1E392L	100	—	
	18.0	31.5	3635	0.016	5000	0.80	7.5	—	—	EEUFC1E392	50	—	
4700	18.0	35.5	3680	0.015	5000	0.80	7.5	—	—	EEUFC1E472	50	—	
5600	18.0	40.0	3735	0.014	5000	0.80	7.5	—	—	EEUFC1E562	50	—	

*1: Ripple current (100 kHz / +105 °C)

*2: Impedance (100 kHz / +20 °C)

- When requesting taped product, please put the letter "B" or "H" between the "()".
Lead wire pitch *B=5 mm, 7.5 mm, H=2.5 mm.
- Please refer to the page of "Taping dimensions".

Characteristics list

Endurance : 105 °C 1000 h / ϕ 4 to ϕ 6.3, 105 °C 2000 h / ϕ 8, 105 °C 3000 h / ϕ 10, 105 °C 5000 h / ϕ 12.5 to ϕ 18

Rated voltage (V)	Capacitance ($\pm 20\%$) (μ F)	Case size (mm)		Specification			Lead length (mm)				Part No.	Min. Packaging Q'ty (PCS)	
		ϕ D	L	Ripple current* ¹ (mA rms)	Impedance* ² (Ω)	Endurance (h)	Lead dia. (ϕ d)	Lead space				Straight leads	Taping
								Straight	Taping *B	Taping *H			
35	6.8	4.0	7.0	65	2.000	1000	0.45	1.5	5.0	2.5	EEAFC1V6R8()	200	2000
	12	5.0	7.0	120	0.950	1000	0.45	2.0	5.0	2.5	EEAFC1V120()	200	2000
	22	5.0	11.0	175	0.800	1000	0.50	2.0	5.0	2.5	EEUFC1V220()	200	2000
	27	5.0	11.0	175	0.800	1000	0.50	2.0	5.0	2.5	EEUFC1V270()	200	2000
		6.3	7.0	200	0.450	1000	0.45	2.5	5.0	2.5	EEAFC1V270()	200	2000
	33	5.0	11.0	175	0.800	1000	0.50	2.0	5.0	2.5	EEUFC1V330()	200	2000
	47	6.3	11.2	290	0.350	1000	0.50	2.5	5.0	2.5	EEUFC1V470()	200	2000
	56	6.3	11.2	290	0.350	1000	0.50	2.5	5.0	2.5	EEUFC1V560()	200	2000
	68	6.3	11.2	290	0.350	1000	0.50	2.5	5.0	2.5	EEUFC1V680()	200	2000
	100	8.0	11.5	555	0.117	2000	0.60	3.5	5.0	—	EEUFC1V101()	200	1000
	120	8.0	11.5	555	0.117	2000	0.60	3.5	5.0	—	EEUFC1V121()	200	1000
	150	8.0	11.5	555	0.117	2000	0.60	3.5	5.0	—	EEUFC1V151()	200	1000
	180	10.0	12.5	755	0.090	3000	0.60	5.0	5.0	—	EEUFC1V181()	200	500
	220	8.0	15.0	730	0.085	2000	0.60	3.5	5.0	—	EEUFC1V221L()	200	1000
		10.0	12.5	755	0.090	3000	0.60	5.0	5.0	—	EEUFC1V221()	200	500
	270	10.0	16.0	1050	0.068	3000	0.60	5.0	5.0	—	EEUFC1V271()	200	500
	330	8.0	20.0	995	0.065	2000	0.60	3.5	5.0	—	EEUFC1V331L()	200	1000
		10.0	16.0	1050	0.068	3000	0.60	5.0	5.0	—	EEUFC1V331()	200	500
	390	10.0	20.0	1220	0.052	3000	0.60	5.0	5.0	—	EEUFC1V391()	200	500
		12.5	15.0	1205	0.065	5000	0.60	5.0	5.0	—	EEUFC1V391S()	200	500
	470	10.0	20.0	1220	0.052	3000	0.60	5.0	5.0	—	EEUFC1V471()	200	500
	560	10.0	25.0	1440	0.045	3000	0.60	5.0	5.0	—	EEUFC1V561()	200	500
		12.5	20.0	1655	0.038	5000	0.60	5.0	5.0	—	EEUFC1V561S()	200	500
	680	10.0	30.0	1815	0.035	3000	0.60	5.0	—	—	EEUFC1V681L	100	—
		12.5	20.0	1655	0.038	5000	0.60	5.0	5.0	—	EEUFC1V681()	200	500
		16.0	15.0	1690	0.043	5000	0.80	7.5	7.5	—	EEUFC1V681S()	100	250
	820	12.5	25.0	1945	0.030	5000	0.60	5.0	5.0	—	EEUFC1V821L()	200	500
		18.0	15.0	2000	0.038	5000	0.80	7.5	7.5	—	EEUFC1V821()	100	250
	1000	12.5	25.0	1945	0.030	5000	0.60	5.0	5.0	—	EEUFC1V102()	200	500
		16.0	20.0	2205	0.029	5000	0.80	7.5	7.5	—	EEUFC1V102S()	100	250
	1200	12.5	30.0	2310	0.025	5000	0.80	5.0	—	—	EEUFC1V122L	100	—
		16.0	20.0	2205	0.029	5000	0.80	7.5	7.5	—	EEUFC1V122()	100	250
	1500	12.5	35.0	2510	0.022	5000	0.80	5.0	—	—	EEUFC1V152L	100	—
		16.0	25.0	2555	0.022	5000	0.80	7.5	7.5	—	EEUFC1V152()	100	250
		18.0	20.0	2490	0.028	5000	0.80	7.5	7.5	—	EEUFC1V152S()	100	250
1800	12.5	40.0	2655	0.018	5000	0.80	5.0	—	—	EEUFC1V182L	100	—	
	16.0	25.0	2555	0.022	5000	0.80	7.5	7.5	—	EEUFC1V182()	100	250	
	18.0	20.0	2490	0.028	5000	0.80	7.5	7.5	—	EEUFC1V182S()	100	250	
2200	16.0	31.5	3010	0.018	5000	0.80	7.5	—	—	EEUFC1V222	100	—	
	18.0	25.0	2740	0.020	5000	0.80	7.5	7.5	—	EEUFC1V222S()	100	250	
2700	16.0	35.5	3150	0.016	5000	0.80	7.5	—	—	EEUFC1V272L	100	—	
	18.0	31.5	3635	0.016	5000	0.80	7.5	—	—	EEUFC1V272	50	—	
3300	18.0	35.5	3680	0.015	5000	0.80	7.5	—	—	EEUFC1V332	50	—	
3900	18.0	40.0	3735	0.014	5000	0.80	7.5	—	—	EEUFC1V392	50	—	

*1: Ripple current (100 kHz / +105 °C)

*2: Impedance (100 kHz / +20 °C)

• When requesting taped product, please put the letter "B" or "H" between the "()".

Lead wire pitch *B=5 mm, 7.5 mm, H=2.5 mm.

• Please refer to the page of "Taping dimensions".

Characteristics list

Endurance : 105 °C 1000 h / $\phi 4$ to $\phi 6.3$, 105 °C 2000 h / $\phi 8$, 105 °C 3000 h / $\phi 10$, 105 °C 5000 h / $\phi 12.5$ to $\phi 18$

Rated voltage (V)	Capacitance ($\pm 20\%$) (μF)	Case size (mm)		Specification			Lead length (mm)				Part No.	Min. Packaging Q'ty (PCS)	
		ϕD	L	Ripple current* ¹ (mA rms)	Impedance* ² (Ω)	Endurance (h)	Lead dia. (ϕd)	Lead space				Straight leads	Taping
								Straight	Taping *B	Taping *H			
50	2.2	5.0	11.0	45	1.800	1000	0.50	2.0	5.0	2.5	EEUFC1H2R2()	200	2000
	3.3	5.0	11.0	65	1.300	1000	0.50	2.0	5.0	2.5	EEUFC1H3R3()	200	2000
	4.7	5.0	11.0	95	1.300	1000	0.50	2.0	5.0	2.5	EEUFC1H4R7()	200	2000
	10	5.0	11.0	125	1.300	1000	0.50	2.0	5.0	2.5	EEUFC1H100L()	200	2000
	12	5.0	11.0	135	1.300	1000	0.50	2.0	5.0	2.5	EEUFC1H120()	200	2000
	15	5.0	11.0	145	1.300	1000	0.50	2.0	5.0	2.5	EEUFC1H150()	200	2000
	18	5.0	11.0	155	1.300	1000	0.50	2.0	5.0	2.5	EEUFC1H180()	200	2000
	22	5.0	11.0	155	1.300	1000	0.50	2.0	5.0	2.5	EEUFC1H220()	200	2000
	33	6.3	11.2	260	0.600	1000	0.50	2.5	5.0	2.5	EEUFC1H330()	200	2000
	39	6.3	11.2	260	0.600	1000	0.50	2.5	5.0	2.5	EEUFC1H390()	200	2000
	47	6.3	11.2	260	0.600	1000	0.50	2.5	5.0	2.5	EEUFC1H470()	200	2000
	68	8.0	11.5	485	0.234	2000	0.60	3.5	5.0	—	EEUFC1H680()	200	1000
	82	8.0	11.5	485	0.234	2000	0.60	3.5	5.0	—	EEUFC1H820()	200	1000
	100	10.0	12.5	615	0.162	3000	0.60	5.0	5.0	—	EEUFC1H101()	200	500
	120	8.0	15.0	635	0.155	2000	0.60	3.5	5.0	—	EEUFC1H121L()	200	1000
		10.0	12.5	615	0.162	3000	0.60	5.0	5.0	—	EEUFC1H121()	200	500
	150	10.0	16.0	850	0.119	3000	0.60	5.0	5.0	—	EEUFC1H151()	200	500
	180	8.0	20.0	860	0.120	2000	0.60	3.5	5.0	—	EEUFC1H181L()	200	1000
		10.0	16.0	850	0.119	3000	0.60	5.0	5.0	—	EEUFC1H181()	200	500
	220	10.0	20.0	1030	0.090	3000	0.60	5.0	5.0	—	EEUFC1H221()	200	500
		12.5	15.0	1150	0.110	5000	0.60	5.0	5.0	—	EEUFC1H221S()	200	500
	270	10.0	25.0	1200	0.082	3000	0.60	5.0	5.0	—	EEUFC1H271()	200	500
	330	10.0	30.0	1610	0.060	3000	0.60	5.0	—	—	EEUFC1H331L	100	—
		12.5	20.0	1480	0.063	5000	0.60	5.0	5.0	—	EEUFC1H331()	200	500
	390	12.5	20.0	1480	0.063	5000	0.60	5.0	5.0	—	EEUFC1H391()	200	500
		16.0	15.0	1610	0.080	5000	0.80	7.5	7.5	—	EEUFC1H391S()	100	250
	470	10.0	30.0	1610	0.060	3000	0.60	5.0	—	—	EEUFC1H471L	100	—
		12.5	25.0	1832	0.050	5000	0.60	5.0	5.0	—	EEUFC1H471()	200	500
	560	12.5	25.0	1832	0.050	5000	0.60	5.0	5.0	—	EEUFC1H561()	200	500
		18.0	15.0	1900	0.068	5000	0.80	7.5	7.5	—	EEUFC1H561S()	100	250
680	12.5	30.0	2215	0.040	5000	0.80	5.0	—	—	EEUFC1H681L	100	—	
	16.0	20.0	1835	0.048	5000	0.80	7.5	7.5	—	EEUFC1H681()	100	250	
820	12.5	35.0	2285	0.034	5000	0.80	5.0	—	—	EEUFC1H821L	100	—	
	18.0	20.0	2420	0.042	5000	0.80	7.5	7.5	—	EEUFC1H821()	100	250	
1000	12.5	40.0	2590	0.030	5000	0.80	5.0	—	—	EEUFC1H102L	100	—	
	16.0	25.0	2235	0.034	5000	0.80	7.5	7.5	—	EEUFC1H102()	100	250	
1200	16.0	31.5	2700	0.028	5000	0.80	7.5	—	—	EEUFC1H122	100	—	
	18.0	25.0	2610	0.029	5000	0.80	7.5	7.5	—	EEUFC1H122S()	100	250	
1500	16.0	35.5	2790	0.025	5000	0.80	7.5	—	—	EEUFC1H152L	100	—	
1800	16.0	40.0	2845	0.023	5000	0.80	7.5	—	—	EEUFC1H182L	100	—	
	18.0	31.5	3000	0.025	5000	0.80	7.5	—	—	EEUFC1H182	50	—	
2200	18.0	35.5	3100	0.023	5000	0.80	7.5	—	—	EEUFC1H222	50	—	

*1: Ripple current (100 kHz / +105 °C)

*2: Impedance (100 kHz / +20 °C)

• When requesting taped product, please put the letter "B" or "H" between the "()".

Lead wire pitch *B=5 mm, 7.5 mm, H=2.5 mm.

• Please refer to the page of "Taping dimensions".

Characteristics list

Endurance : 105 °C 1000 h / $\phi 4$ to $\phi 6.3$, 105 °C 2000 h / $\phi 8$, 105 °C 3000 h / $\phi 10$, 105 °C 5000 h / $\phi 12.5$ to $\phi 18$

Rated voltage (V)	Capacitance ($\pm 20\%$) (μF)	Case size (mm)		Specification			Lead length (mm)				Part No.	Min. Packaging Q'ty (PCS)	
		ϕD	L	Ripple current* ¹ (mA rms)	Impedance* ² (Ω)	Endurance (h)	Lead dia. (ϕd)	Lead space				Straight leads	Taping
								Straight	Taping *B	Taping *H			
63	12	5.0	11.0	145	2.000	1000	0.50	2.0	5.0	2.5	EEUFC1J120()	200	2000
	22	6.3	11.2	240	1.000	1000	0.50	2.5	5.0	2.5	EEUFC1J220()	200	2000
	33	6.3	11.2	240	1.000	1000	0.50	2.5	5.0	2.5	EEUFC1J330()	200	2000
	47	8.0	11.5	405	0.342	2000	0.60	3.5	5.0	—	EEUFC1J470()	200	1000
	56	8.0	11.5	405	0.342	2000	0.60	3.5	5.0	—	EEUFC1J560()	200	1000
	68	8.0	11.5	405	0.342	2000	0.60	3.5	5.0	—	EEUFC1J680()	200	1000
	82	10.0	12.5	535	0.256	3000	0.60	5.0	5.0	—	EEUFC1J820()	200	500
	100	8.0	15.0	535	0.230	2000	0.60	3.5	5.0	—	EEUFC1J101L()	200	1000
		10.0	12.5	535	0.256	3000	0.60	5.0	5.0	—	EEUFC1J101()	200	500
	120	10.0	16.0	600	0.194	3000	0.60	5.0	5.0	—	EEUFC1J121()	200	500
	150	8.0	20.0	690	0.178	2000	0.60	3.5	5.0	—	EEUFC1J151()	200	1000
	180	10.0	20.0	885	0.147	3000	0.60	5.0	5.0	—	EEUFC1J181()	200	500
		12.5	15.0	1020	0.150	5000	0.60	5.0	5.0	—	EEUFC1J181S()	200	500
	220	10.0	20.0	885	0.147	3000	0.60	5.0	5.0	—	EEUFC1J221X()	200	500
		10.0	25.0	1050	0.130	3000	0.60	5.0	5.0	—	EEUFC1J221()	200	500
		12.5	20.0	1285	0.085	5000	0.60	5.0	5.0	—	EEUFC1J221S()	200	500
	270	16.0	15.0	1410	0.090	5000	0.80	7.5	7.5	—	EEUFC1J271()	100	250
	330	10.0	30.0	1300	0.090	3000	0.60	5.0	—	—	EEUFC1J331L	100	—
		12.5	20.0	1285	0.085	5000	0.60	5.0	5.0	—	EEUFC1J331()	200	500
	390	12.5	25.0	1720	0.070	5000	0.60	5.0	5.0	—	EEUFC1J391()	200	500
		18.0	15.0	1690	0.086	5000	0.80	7.5	7.5	—	EEUFC1J391S()	100	250
	470	12.5	30.0	2090	0.055	5000	0.80	5.0	—	—	EEUFC1J471L	100	—
		16.0	20.0	1765	0.059	5000	0.80	7.5	7.5	—	EEUFC1J471()	100	250
	560	16.0	25.0	2160	0.050	5000	0.80	7.5	7.5	—	EEUFC1J561()	100	250
	680	12.5	35.0	2265	0.047	5000	0.80	5.0	—	—	EEUFC1J681L	100	—
		16.0	25.0	2160	0.050	5000	0.80	7.5	7.5	—	EEUFC1J681()	100	250
		18.0	20.0	2290	0.055	5000	0.80	7.5	7.5	—	EEUFC1J681S()	100	250
	820	12.5	40.0	2560	0.042	5000	0.80	5.0	—	—	EEUFC1J821L	100	—
		16.0	31.5	2670	0.043	5000	0.80	7.5	—	—	EEUFC1J821	100	—
		18.0	25.0	2585	0.043	5000	0.80	7.5	7.5	—	EEUFC1J821S()	100	250
	1000	16.0	31.5	2670	0.043	5000	0.80	7.5	—	—	EEUFC1J102U	100	—
		16.0	35.5	2770	0.036	5000	0.80	7.5	—	—	EEUFC1J102	100	—
	1200	16.0	40.0	2825	0.030	5000	0.80	7.5	—	—	EEUFC1J122L	100	—
18.0		31.5	2950	0.032	5000	0.80	7.5	—	—	EEUFC1J122	50	—	
1500	18.0	35.5	3095	0.030	5000	0.80	7.5	—	—	EEUFC1J152	50	—	
1800	18.0	40.0	3205	0.025	5000	0.80	7.5	—	—	EEUFC1J182	50	—	

*1: Ripple current (100 kHz / +105 °C)

*2: Impedance (100 kHz / +20 °C)

- When requesting taped product, please put the letter "B" or "H" between the "()".
Lead wire pitch *B=5 mm, 7.5 mm, H=2.5 mm.
- Please refer to the page of "Taping dimensions".

Characteristics list

Endurance : 105 °C 1000 h / ϕ 4 to ϕ 6.3, 105 °C 2000 h / ϕ 8, 105 °C 3000 h / ϕ 10, 105 °C 5000 h / ϕ 12.5 to ϕ 18

Rated voltage (V)	Capacitance ($\pm 20\%$) (μ F)	Case size (mm)		Specification			Lead length (mm)				Part No.	Min. Packaging Q'ty (PCS)	
		ϕ D	L	Ripple current* ¹ (mA rms)	Impedance* ² (Ω)	Endurance (h)	Lead dia. (ϕ d)	Lead space				Straight leads	Taping
								Straight	Taping *B	Taping *H			
100	5.6	5.0	11.0	80	4.100	1000	0.5	2.0	5.0	2.5	EEUFC2A5R6()	200	2000
	12	6.3	11.2	114	1.800	1000	0.5	2.5	5.0	2.5	EEUFC2A120()	200	2000
	22	8.0	11.5	260	0.680	2000	0.6	3.5	5.0	—	EEUFC2A220()	200	1000
	33	8.0	15.0	340	0.450	2000	0.6	3.5	5.0	—	EEUFC2A330L()	200	1000
		10.0	12.5	306	0.530	3000	0.6	5.0	5.0	—	EEUFC2A330()	200	500
	39	8.0	20.0	455	0.330	2000	0.6	5.0	5.0	—	EEUFC2A390L()	200	1000
		10.0	16.0	400	0.360	3000	0.6	5.0	5.0	—	EEUFC2A390()	200	500
	47	10.0	20.0	463	0.240	3000	0.6	5.0	5.0	—	EEUFC2A470()	200	500
	56	10.0	20.0	463	0.240	3000	0.6	5.0	5.0	—	EEUFC2A560()	200	500
	68	10.0	25.0	599	0.210	3000	0.6	5.0	5.0	—	EEUFC2A680L()	200	500
		12.5	15.0	511	0.230	5000	0.6	5.0	5.0	—	EEUFC2A680()	200	500
	100	10.0	30.0	698	0.150	3000	0.6	5.0	—	—	EEUFC2A101L	100	—
		12.5	20.0	671	0.180	5000	0.6	5.0	5.0	—	EEUFC2A101()	200	500
	120	16.0	15.0	793	0.140	5000	0.8	7.5	7.5	—	EEUFC2A121S()	100	250
	150	12.5	25.0	807	0.110	5000	0.6	5.0	5.0	—	EEUFC2A151()	200	500
		18.0	15.0	917	0.120	5000	0.8	7.5	7.5	—	EEUFC2A151S()	100	250
	180	12.5	30.0	937	0.098	5000	0.8	5.0	—	—	EEUFC2A181L	100	—
		16.0	20.0	995	0.110	5000	0.8	7.5	7.5	—	EEUFC2A181()	100	250
	220	12.5	35.0	1040	0.087	5000	0.8	5.0	—	—	EEUFC2A221L	100	—
		16.0	25.0	1170	0.089	5000	0.8	7.5	7.5	—	EEUFC2A221()	100	250
270	12.5	40.0	1130	0.072	5000	0.8	5.0	—	—	EEUFC2A271L	100	—	
	18.0	20.0	1230	0.080	5000	0.8	7.5	7.5	—	EEUFC2A271S()	100	250	
330	16.0	31.5	1520	0.062	5000	0.8	7.5	—	—	EEUFC2A331	100	—	
	18.0	25.0	1420	0.070	5000	0.8	7.5	7.5	—	EEUFC2A331S()	100	250	
390	16.0	35.5	1730	0.053	5000	0.8	7.5	—	—	EEUFC2A391L	100	—	
	18.0	31.5	1600	0.062	5000	0.8	7.5	—	—	EEUFC2A391	50	—	
470	16.0	40.0	1920	0.047	5000	0.8	7.5	—	—	EEUFC2A471	100	—	
560	18.0	35.5	1770	0.041	5000	0.8	7.5	—	—	EEUFC2A561	50	—	
680	18.0	40.0	2300	0.036	5000	0.8	7.5	—	—	EEUFC2A681	50	—	

*1: Ripple current (100 kHz / +105 °C)

*2: Impedance (100 kHz / +20 °C)

• When requesting taped product, please put the letter "B" or "H" between the "()".

Lead wire pitch *B=5 mm, 7.5 mm, H=2.5 mm.

• Please refer to the page of "Taping dimensions".



This Series is no longer available for purchase in the country of Japan.



Radial Lead Type

FK-A series

Features

- Endurance : 105 °C 3000 h to 5000 h
- Low impedance (10 % to 30 % less than FC Series)
- Miniaturization (30 % to 40 % less than FC Series)
- AEC-Q200 compliant
- RoHS compliant

Specifications

Category temp. range	-55 °C to +105 °C						
Rated voltage range	6.3 V to 35 V						
Capacitance range	180 μF to 12000 μF						
Capacitance tolerance	±20 % (120 Hz / +20°C)						
Leakage current	$I \leq 0.01 CV (\mu A)$ After 2 minutes						
Dissipation factor (tan δ)	Rated voltage (V)	6.3	10	16	25	35	(120 Hz / +20°C)
	Dissipation factor (tan δ)	0.22	0.19	0.16	0.14	0.12	
Endurance	For capacitance value $\geq 1000 \mu F$, add 0.02 per every 1000 μF.						
	After following life test with DC voltage and +105 °C±2 °C ripple current value applied (The sum of DC and ripple peak voltage shall not exceed the rated working voltage)when the capacitors are restored to 20 °C, the capacitors shall meet the limits specified bellow.						
	Duration ø8 : 3000 h, ø10 : 4000 h, ø12.5 to ø18 : 5000 h						
	Capacitance change	Within ±20 % of the initial value					
	Dissipation factor (tan δ)	≤ 200 % of the initial limit					
Shelf life	DC leakage current	Within the initial limit					
	After storage for 1000 h at +105 °C±2 °C with no voltage applied and then being stabilized at +20 °C, capacitors shall meet the limits specified in endurance. (With voltage treatment)						

Frequency correction factor for ripple current

Cap. (μF) \ Freq. (Hz)	60	120	1 k	10 k	100 k
180 to 330	0.60	0.70	0.85	0.95	1.00
390 to 1000	0.65	0.75	0.90	0.98	1.00
1200 to 12000	0.75	0.80	0.95	1.00	1.00

Dimensions

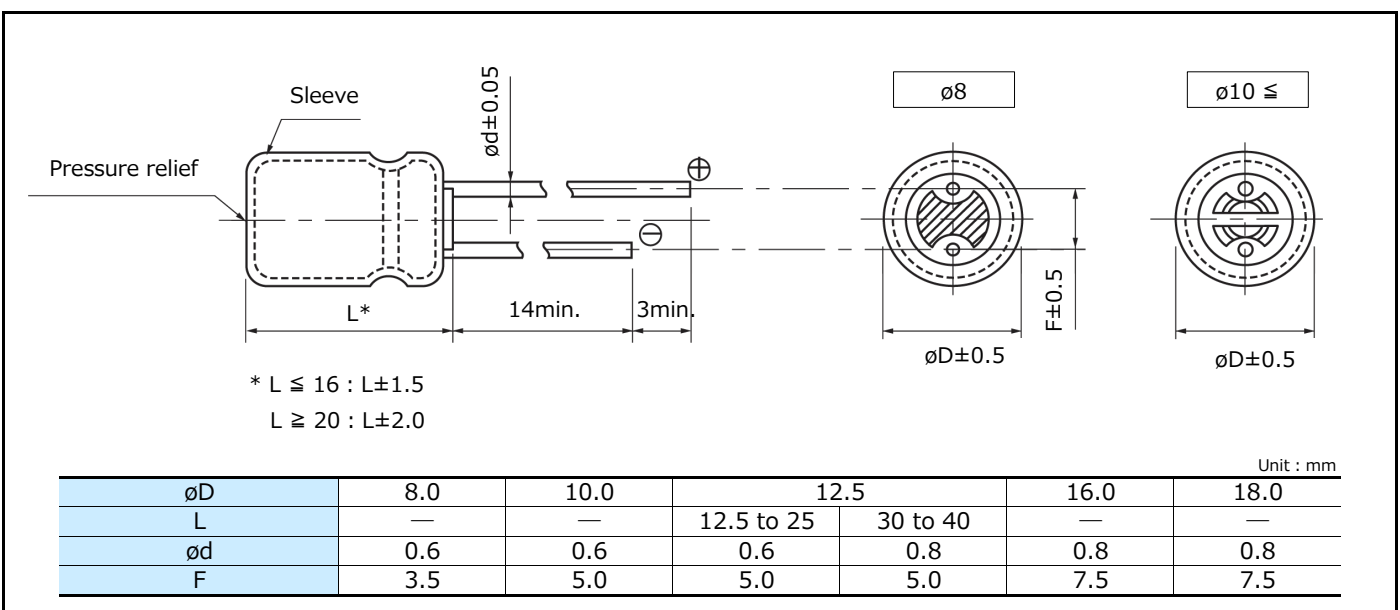

Case size/ Impedance/ Ripple current

Case size (mm) (ϕ D×L)	Impedance (Ω) (100 kHz)		Ripple current (mA rms) (100 kHz)
	+20 °C	-10 °C	+105 °C
8 × 11.5	0.090	0.180	630
8 × 15	0.062	0.124	860
8 × 20	0.044	0.088	1220
10 × 12.5	0.063	0.126	900
10 × 16	0.049	0.098	1240
10 × 20	0.035	0.070	1490
10 × 25	0.033	0.066	1680
10 × 30	0.025	0.050	2140
12.5 × 15	0.048	0.096	1400
12.5 × 20	0.029	0.058	1890
12.5 × 25	0.022	0.044	2280
12.5 × 30	0.018	0.036	2720
12.5 × 35	0.016	0.032	2940
12.5 × 40	0.014	0.028	3010
16 × 15	0.038	0.076	1800
16 × 20	0.026	0.052	2330
16 × 25	0.019	0.038	2760
18 × 15	0.036	0.072	2060
18 × 20	0.025	0.050	2640
18 × 25	0.018	0.036	2850

Characteristics list

Endurance : 105 °C 3000 h / ø8, 105 °C 4000 h / ø10, 105 °C 5000 h / ø12.5 to ø18

Rated voltage (V)	Capacitance (±20 %) (μF)	Case size (mm)		Specification			Lead length (mm)			Part No.	Min. Packaging Q'ty (PCS)	
		øD	L	Ripple current* ¹ (mA rms)	Impe-dance* ² (Ω)	Endu-rance (h)	Lead dia. (ød)	Lead space			Straight leads	Taping
								Straight	Taping *B			
6.3	680	8.0	11.5	630	0.090	3000	0.6	3.5	5.0	EEUFK0J681()	200	1000
	1000	8.0	15.0	860	0.062	3000	0.6	3.5	5.0	EEUFK0J102L()	200	1000
		10.0	12.5	900	0.063	4000	0.6	5.0	5.0	EEUFK0J102()	200	500
	1500	8.0	20.0	1220	0.044	3000	0.6	3.5	5.0	EEUFK0J152L()	200	1000
		10.0	16.0	1240	0.049	4000	0.6	5.0	5.0	EEUFK0J152()	200	500
	1800	12.5	15.0	1400	0.048	5000	0.6	5.0	5.0	EEUFK0J182S()	200	500
	2200	10.0	20.0	1490	0.035	4000	0.6	5.0	5.0	EEUFK0J222()	200	500
		10.0	25.0	1680	0.033	4000	0.6	5.0	5.0	EEUFK0J222L()	200	500
	3300	10.0	30.0	2140	0.025	4000	0.6	5.0	—	EEUFK0J332L	100	—
		12.5	20.0	1890	0.029	5000	0.6	5.0	5.0	EEUFK0J332()	200	500
		16.0	15.0	1800	0.038	5000	0.8	7.5	7.5	EEUFK0J332S()	100	250
	4700	12.5	25.0	2280	0.022	5000	0.6	5.0	5.0	EEUFK0J472()	200	500
		18.0	15.0	2060	0.036	5000	0.8	7.5	7.5	EEUFK0J472S()	100	250
	5600	12.5	30.0	2720	0.018	5000	0.8	5.0	—	EEUFK0J562L	100	—
		16.0	20.0	2330	0.026	5000	0.8	7.5	7.5	EEUFK0J562S()	100	250
	6800	12.5	35.0	2940	0.016	5000	0.8	5.0	—	EEUFK0J682L	100	—
	8200	12.5	40.0	3010	0.014	5000	0.8	5.0	—	EEUFK0J822L	100	—
		16.0	25.0	2760	0.019	5000	0.8	7.5	7.5	EEUFK0J822()	100	250
18.0		20.0	2640	0.025	5000	0.8	7.5	7.5	EEUFK0J822S()	100	250	
12000	18.0	25.0	2850	0.018	5000	0.8	7.5	7.5	EEUFK0J123S()	100	250	
10	560	8.0	11.5	630	0.090	3000	0.6	3.5	5.0	EEUFK1A561()	200	1000
	820	8.0	15.0	860	0.062	3000	0.6	3.5	5.0	EEUFK1A821L()	200	1000
		10.0	12.5	900	0.063	4000	0.6	5.0	5.0	EEUFK1A821()	200	500
	1200	8.0	20.0	1220	0.044	3000	0.6	3.5	5.0	EEUFK1A122L()	200	1000
		10.0	16.0	1240	0.049	4000	0.6	5.0	5.0	EEUFK1A122()	200	500
	1500	12.5	15.0	1400	0.048	5000	0.6	5.0	5.0	EEUFK1A152S()	200	500
	1800	10.0	20.0	1490	0.035	4000	0.6	5.0	5.0	EEUFK1A182()	200	500
		10.0	25.0	1680	0.033	4000	0.6	5.0	5.0	EEUFK1A182L()	200	500
	2700	10.0	30.0	2140	0.025	4000	0.6	5.0	—	EEUFK1A272L	100	—
		12.5	20.0	1890	0.029	5000	0.6	5.0	5.0	EEUFK1A272()	200	500
		16.0	15.0	1800	0.038	5000	0.8	7.5	7.5	EEUFK1A272S()	100	250
	3900	12.5	25.0	2280	0.022	5000	0.6	5.0	5.0	EEUFK1A392()	200	500
		18.0	15.0	2060	0.036	5000	0.8	7.5	7.5	EEUFK1A392S()	100	250
	4700	12.5	30.0	2720	0.018	5000	0.8	5.0	—	EEUFK1A472L	100	—
		16.0	20.0	2330	0.026	5000	0.8	7.5	7.5	EEUFK1A472S()	100	250
	5600	12.5	35.0	2940	0.016	5000	0.8	5.0	—	EEUFK1A562L	100	—
	6800	12.5	40.0	3010	0.014	5000	0.8	5.0	—	EEUFK1A682L	100	—
		16.0	25.0	2760	0.019	5000	0.8	7.5	7.5	EEUFK1A682()	100	250
18.0		20.0	2640	0.025	5000	0.8	7.5	7.5	EEUFK1A682S()	100	250	
8200	18.0	25.0	2850	0.018	5000	0.8	7.5	7.5	EEUFK1A822S()	100	250	

*1: Ripple current (100 kHz / +105 °C)

*2: Impedance (100 kHz / +20 °C)

- When requesting taped product, please put the letter "B" between the "()". Lead wire pitch *B=5 mm, 7.5 mm.
- Please refer to the page of "Taping dimensions".

Characteristics list

Endurance : 105 °C 3000 h / ø8, 105 °C 4000 h / ø10, 105 °C 5000 h / ø12.5 to ø18

Rated voltage (V)	Capacitance (±20 %) (μF)	Case size (mm)		Specification			Lead length (mm)			Part No.	Min. Packaging Q'ty (PCS)	
		øD	L	Ripple current* ¹ (mA rms)	Impe-dance* ² (Ω)	Endu-rance (h)	Lead dia. (ød)	Lead space			Straight leads	Taping
								Straight	Taping *B			
16	390	8.0	11.5	630	0.090	3000	0.6	3.5	5.0	EEUFK1C391()	200	1000
	680	8.0	15.0	860	0.062	3000	0.6	3.5	5.0	EEUFK1C681L()	200	1000
		10.0	12.5	900	0.063	4000	0.6	5.0	5.0	EEUFK1C681()	200	500
	820	8.0	20.0	1220	0.044	3000	0.6	3.5	5.0	EEUFK1C821L()	200	1000
	1000	10.0	16.0	1240	0.049	4000	0.6	5.0	5.0	EEUFK1C102()	200	500
	1200	10.0	20.0	1490	0.035	4000	0.6	5.0	5.0	EEUFK1C122()	200	500
		12.5	15.0	1400	0.048	5000	0.6	5.0	5.0	EEUFK1C122S()	200	500
	1500	10.0	25.0	1680	0.033	4000	0.6	5.0	5.0	EEUFK1C152L()	200	500
	2200	10.0	30.0	2140	0.025	4000	0.6	5.0	—	EEUFK1C222L	100	—
		12.5	20.0	1890	0.029	5000	0.6	5.0	5.0	EEUFK1C222()	200	500
		16.0	15.0	1800	0.038	5000	0.8	7.5	7.5	EEUFK1C222S()	100	250
	2700	12.5	25.0	2280	0.022	5000	0.6	5.0	5.0	EEUFK1C272()	200	500
		18.0	15.0	2060	0.036	5000	0.8	7.5	7.5	EEUFK1C272S()	100	250
	3300	12.5	30.0	2720	0.018	5000	0.8	5.0	—	EEUFK1C332L	100	—
	3900	12.5	35.0	2940	0.016	5000	0.8	5.0	—	EEUFK1C392L	100	—
		16.0	20.0	2330	0.026	5000	0.8	7.5	7.5	EEUFK1C392S()	100	250
4700	12.5	40.0	3010	0.014	5000	0.8	5.0	—	EEUFK1C472L	100	—	
	18.0	20.0	2640	0.025	5000	0.8	7.5	7.5	EEUFK1C472S()	100	250	
5600	16.0	25.0	2760	0.019	5000	0.8	7.5	7.5	EEUFK1C562()	100	250	
6800	18.0	25.0	2850	0.018	5000	0.8	7.5	7.5	EEUFK1C682S()	100	250	
25	270	8.0	11.5	630	0.090	3000	0.6	3.5	5.0	EEUFK1E271()	200	1000
	390	8.0	15.0	860	0.062	3000	0.6	3.5	5.0	EEUFK1E391L()	200	1000
	470	10.0	12.5	900	0.063	4000	0.6	5.0	5.0	EEUFK1E471()	200	500
	560	8.0	20.0	1220	0.044	3000	0.6	3.5	5.0	EEUFK1E561L()	200	1000
		10.0	16.0	1240	0.049	4000	0.6	5.0	5.0	EEUFK1E561()	200	500
	820	10.0	20.0	1490	0.035	4000	0.6	5.0	5.0	EEUFK1E821()	200	500
		12.5	15.0	1400	0.048	5000	0.6	5.0	5.0	EEUFK1E821S()	200	500
	1000	10.0	25.0	1680	0.033	4000	0.6	5.0	5.0	EEUFK1E102L()	200	500
	1200	12.5	20.0	1890	0.029	5000	0.6	5.0	5.0	EEUFK1E122()	200	500
	1500	10.0	30.0	2140	0.025	4000	0.6	5.0	—	EEUFK1E152L	100	—
		16.0	15.0	1800	0.038	5000	0.8	7.5	7.5	EEUFK1E152S()	100	250
	1800	12.5	25.0	2280	0.022	5000	0.6	5.0	5.0	EEUFK1E182()	200	500
		18.0	15.0	2060	0.036	5000	0.8	7.5	7.5	EEUFK1E182S()	100	250
	2200	12.5	30.0	2720	0.018	5000	0.8	5.0	—	EEUFK1E222L	100	—
		16.0	20.0	2330	0.026	5000	0.8	7.5	7.5	EEUFK1E222S()	100	250
	2700	12.5	35.0	2940	0.016	5000	0.8	5.0	—	EEUFK1E272L	100	—
3300	12.5	40.0	3010	0.014	5000	0.8	5.0	—	EEUFK1E332L	100	—	
	16.0	25.0	2760	0.019	5000	0.8	7.5	7.5	EEUFK1E332()	100	250	
	18.0	20.0	2640	0.025	5000	0.8	7.5	7.5	EEUFK1E332S()	100	250	
4700	18.0	25.0	2850	0.018	5000	0.8	7.5	7.5	EEUFK1E472S()	100	250	

*1: Ripple current (100 kHz / +105 °C)

*2: Impedance (100 kHz / +20 °C)

- When requesting taped product, please put the letter "B" between the "()". Lead wire pitch *B=5 mm, 7.5 mm.
- Please refer to the page of "Taping dimensions".

Characteristics list

Endurance : 105 °C 3000 h / ø8, 105 °C 4000 h / ø10, 105 °C 5000 h / ø12.5 to ø18

Rated voltage (V)	Capacitance (±20 %) (μF)	Case size (mm)		Specification			Lead length (mm)			Part No.	Min. Packaging Q'ty (PCS)	
		øD	L	Ripple current* ¹ (mA rms)	Impe-dance* ² (Ω)	Endu-rance (h)	Lead dia. (ød)	Lead space			Straight leads	Taping
								Straight	Taping *B			
35	180	8.0	11.5	630	0.090	3000	0.6	3.5	5.0	EEUFK1V181()	200	1000
	270	8.0	15.0	860	0.062	3000	0.6	3.5	5.0	EEUFK1V271L()	200	1000
		10.0	12.5	900	0.063	4000	0.6	5.0	5.0	EEUFK1V271()	200	500
	390	8.0	20.0	1220	0.044	3000	0.6	3.5	5.0	EEUFK1V391L()	200	1000
		10.0	16.0	1240	0.049	4000	0.6	5.0	5.0	EEUFK1V391()	200	500
	560	10.0	20.0	1490	0.035	4000	0.6	5.0	5.0	EEUFK1V561()	200	500
		12.5	15.0	1400	0.048	5000	0.6	5.0	5.0	EEUFK1V561S()	200	500
	680	10.0	25.0	1680	0.033	4000	0.6	5.0	5.0	EEUFK1V681L()	200	500
	820	12.5	20.0	1890	0.029	5000	0.6	5.0	5.0	EEUFK1V821()	200	500
	1000	10.0	30.0	2140	0.025	4000	0.6	5.0	—	EEUFK1V102L	100	—
		16.0	15.0	1800	0.038	5000	0.8	7.5	7.5	EEUFK1V102S()	100	250
	1200	12.5	25.0	2280	0.022	5000	0.6	5.0	5.0	EEUFK1V122()	200	500
		18.0	15.0	2060	0.036	5000	0.8	7.5	7.5	EEUFK1V122S()	100	250
	1500	12.5	30.0	2720	0.018	5000	0.8	5.0	—	EEUFK1V152L	100	—
	1800	12.5	35.0	2940	0.016	5000	0.8	5.0	—	EEUFK1V182L	100	—
		16.0	20.0	2330	0.026	5000	0.8	7.5	7.5	EEUFK1V182S()	100	250
	2200	12.5	40.0	3010	0.014	5000	0.8	5.0	—	EEUFK1V222L	100	—
		16.0	25.0	2760	0.019	5000	0.8	7.5	7.5	EEUFK1V222()	100	250
18.0		20.0	2640	0.025	5000	0.8	7.5	7.5	EEUFK1V222S()	100	250	
3300	18.0	25.0	2850	0.018	5000	0.8	7.5	7.5	EEUFK1V332S()	100	250	

*1: Ripple current (100 kHz / +105 °C)

*2: Impedance (100 kHz / +20 °C)

- When requesting taped product, please put the letter "B" between the "()". Lead wire pitch *B=5 mm, 7.5 mm.
- Please refer to the page of "Taping dimensions".



This Series is no longer available for purchase in the country of Japan.



Radial Lead Type

FM-A series

Features

- Endurance : 105 °C 2000 h to 7000 h
- Low impedance (40 % to 70 % less than FC series)
- RoHS compliant

Specifications

Category temp. range	-40 °C to +105 °C							
Rated voltage range	6.3 V to 50 V							
Capacitance range	22 μF to 6800 μF							
Capacitance tolerance	±20 % (120 Hz / +20°C)							
Leakage current	$I \leq 0.01 CV (\mu A)$ After 2 minutes							
Dissipation factor (tan δ)	Rated voltage (V)	6.3	10	16	25	35	50	(120 Hz / +20°C)
	Dissipation factor (tan δ)	0.22	0.19	0.16	0.14	0.12	0.10	
Endurance	After following life test with DC voltage and +105 °C±2 °C ripple current value applied (The sum of DC and ripple peak voltage shall not exceed the rated working voltage)when the capacitors are restored to 20 °C, the capacitors shall meet the limits specified bellow. Duration ø5 to ø6.3 : 2000 h, ø8×11.5 to ø8×15: 3000 h ø8×20 to ø10×16 : 4000 h, ø10×20 to ø12.5×20/ ø16×20 : 5000 h ø12.5×25 to ø12.5×35/ ø16×25 : 7000 h							
	Capacitance change	Within ±25 % of the initial value (6.3 V to 10 V : ±30 %)						
	Dissipation factor (tan δ)	≤ 200 % of the initial limit						
	DC leakage current	Within the initial limit						
Shelf life	After storage for 1000 h at +105 °C±2 °C with no voltage applied and then being stabilized at +20 °C, capacitors shall meet the limits specified in endurance. (With voltage treatment)							

Frequency correction factor for ripple current

Cap. (μF) \ Freq. (Hz)	60	120	1 k	10 k	100 k
2.2 to 33	0.45	0.55	0.75	0.90	1.00
47 to 330	0.60	0.70	0.85	0.95	1.00
390 to 1000	0.65	0.75	0.90	0.98	1.00
1200 to 6800	0.75	0.80	0.95	1.00	1.00

Dimensions

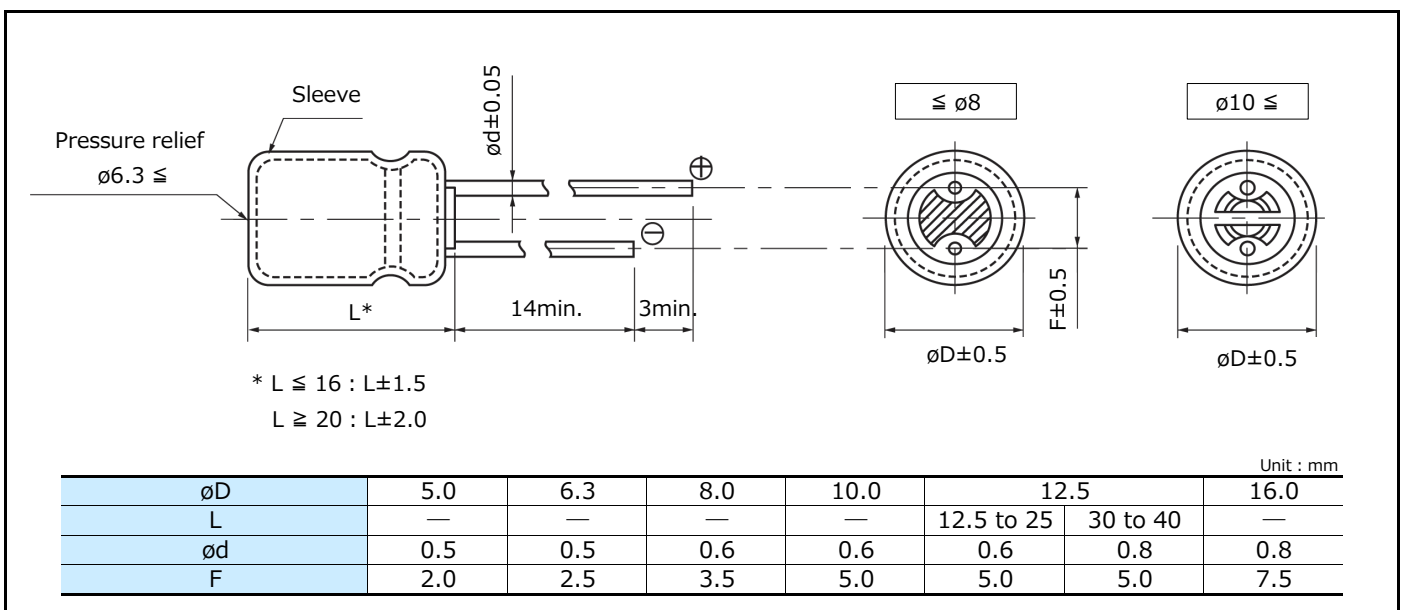

Case size/ Impedance/ Ripple current

R. voltage (V) Case size (mm) (ϕ D×L)	6.3 to 35			50		
	Impedance* ¹ (Ω)		Ripple current* ¹ (mA rms)	Impedance* ¹ (Ω)		Ripple current* ¹ (mA rms)
	+20 °C	-10 °C	+105 °C	+20 °C	-10 °C	+105 °C
5 × 11	0.300	1.000	280	0.340	1.130	250
6.3 × 11.2	0.130	0.430	455	0.140	0.460	405
8 × 11.5	0.056	0.168	950	0.061	0.183	870
8 × 15	0.041	0.123	1240	0.045	0.135	1140
8 × 20	0.030	0.090	1560	0.033	0.099	1430
10 × 12.5	0.038	0.114	1290	0.042	0.126	1170
10 × 16	0.026	0.078	1790	0.030	0.090	1650
10 × 20	0.019	0.057	2180	0.023	0.069	1890
10 × 25	0.018	0.054	2470	0.022	0.066	2150
12.5 × 20	0.018	0.045	2600	0.022	0.055	2260
12.5 × 25	0.015	0.038	3190	0.018	0.045	2660
12.5 × 30	0.013	0.033	3630	0.016	0.040	3160
12.5 × 35	0.012	0.030	3750	0.014	0.035	3270
16 × 20	0.017	0.043	3300	0.019	0.048	2870
16 × 25	0.014	0.035	3820	0.016	0.040	3320

*1: 100 kHz

Characteristics list

Rated voltage (V)	Capacitance (±20 %) (μF)	Case size (mm)		Specification			Lead length (mm)				Part No.	Min. Packaging Q'ty (PCS)	
		øD	L	Ripple current ^{*1} (mA rms)	Impe-dance ^{*2} (Ω)	Endu-rance (h)	Lead dia. (ød)	Lead space				Straight leads	Taping
								Straight	Taping *B	Taping *H			
6.3	150	5.0	11.0	280	0.300	2000	0.5	2.0	5.0	2.5	EEUFM0J151()	200	2000
	330	6.3	11.2	455	0.130	2000	0.5	2.5	5.0	2.5	EEUFM0J331()	200	2000
	560	8.0	11.5	950	0.056	3000	0.6	3.5	5.0	—	EEUFM0J561()	200	1000
	820	8.0	15.0	1240	0.041	3000	0.6	3.5	5.0	—	EEUFM0J821L()	200	1000
	1000	10.0	12.5	1290	0.038	4000	0.6	5.0	5.0	—	EEUFM0J102()	200	500
	1200	8.0	20.0	1560	0.030	4000	0.6	3.5	5.0	—	EEUFM0J122L()	200	1000
		10.0	16.0	1790	0.026	4000	0.6	5.0	5.0	—	EEUFM0J122()	200	500
	1500	10.0	20.0	2180	0.019	5000	0.6	5.0	5.0	—	EEUFM0J152()	200	500
	2200	10.0	25.0	2470	0.018	5000	0.6	5.0	5.0	—	EEUFM0J222L()	200	500
	3300	12.5	20.0	2600	0.018	5000	0.6	5.0	5.0	—	EEUFM0J332()	200	500
	3900	12.5	25.0	3190	0.015	7000	0.6	5.0	5.0	—	EEUFM0J392()	200	500
	4700	12.5	30.0	3630	0.013	7000	0.8	5.0	—	—	EEUFM0J472L	100	—
	5600	12.5	35.0	3750	0.012	7000	0.8	5.0	—	—	EEUFM0J562L	100	—
		16.0	20.0	3300	0.017	5000	0.8	7.5	7.5	—	EEUFM0J562S()	100	250
	6800	16.0	25.0	3820	0.014	7000	0.8	7.5	7.5	—	EEUFM0J682()	100	250
10	100	5.0	11.0	280	0.300	2000	0.5	2.0	5.0	2.5	EEUFM1A101()	200	2000
	220	6.3	11.2	455	0.130	2000	0.5	2.5	5.0	2.5	EEUFM1A221()	200	2000
	470	8.0	11.5	950	0.056	3000	0.6	3.5	5.0	—	EEUFM1A471()	200	1000
	680	8.0	15.0	1240	0.041	3000	0.6	3.5	5.0	—	EEUFM1A681L()	200	1000
		10.0	12.5	1290	0.038	4000	0.6	5.0	5.0	—	EEUFM1A681()	200	500
	1000	8.0	20.0	1560	0.030	4000	0.6	3.5	5.0	—	EEUFM1A102L()	200	1000
		10.0	16.0	1790	0.026	4000	0.6	5.0	5.0	—	EEUFM1A102()	200	500
	1200	10.0	20.0	2180	0.019	5000	0.6	5.0	5.0	—	EEUFM1A122()	200	500
	1500	10.0	25.0	2470	0.018	5000	0.6	5.0	5.0	—	EEUFM1A152L()	200	500
	2200	12.5	20.0	2600	0.018	5000	0.6	5.0	5.0	—	EEUFM1A222()	200	500
	3300	12.5	25.0	3190	0.015	7000	0.6	5.0	5.0	—	EEUFM1A332()	200	500
	3900	12.5	30.0	3630	0.013	7000	0.8	5.0	—	—	EEUFM1A392L	100	—
		16.0	20.0	3300	0.017	5000	0.8	7.5	7.5	—	EEUFM1A392S()	100	250
	4700	12.5	35.0	3750	0.012	7000	0.8	5.0	—	—	EEUFM1A472L	100	—
	5600	16.0	25.0	3820	0.014	7000	0.8	7.5	7.5	—	EEUFM1A562()	100	250
16	68	5.0	11.0	280	0.300	2000	0.5	2.0	5.0	2.5	EEUFM1C680()	200	2000
	120	6.3	11.2	455	0.130	2000	0.5	2.5	5.0	2.5	EEUFM1C121()	200	2000
	330	8.0	11.5	950	0.056	3000	0.6	3.5	5.0	—	EEUFM1C331()	200	1000
	470	8.0	15.0	1240	0.041	3000	0.6	3.5	5.0	—	EEUFM1C471L()	200	1000
		10.0	12.5	1290	0.038	4000	0.6	5.0	5.0	—	EEUFM1C471()	200	500
	680	8.0	20.0	1560	0.030	4000	0.6	3.5	5.0	—	EEUFM1C681L()	200	1000
		10.0	16.0	1790	0.026	4000	0.6	5.0	5.0	—	EEUFM1C681()	200	500
	1000	10.0	20.0	2180	0.019	5000	0.6	5.0	5.0	—	EEUFM1C102()	200	500
	1200	10.0	25.0	2470	0.018	5000	0.6	5.0	5.0	—	EEUFM1C122L()	200	500
	1500	12.5	20.0	2600	0.018	5000	0.6	5.0	5.0	—	EEUFM1C152()	200	500
	2200	12.5	25.0	3190	0.015	7000	0.6	5.0	5.0	—	EEUFM1C222()	200	500
	2700	12.5	30.0	3630	0.013	7000	0.8	5.0	—	—	EEUFM1C272L	100	—
		16.0	20.0	3300	0.017	5000	0.8	7.5	7.5	—	EEUFM1C272S()	100	250
	3300	12.5	35.0	3750	0.012	7000	0.8	5.0	—	—	EEUFM1C332L	100	—
	3900	16.0	25.0	3820	0.014	7000	0.8	7.5	7.5	—	EEUFM1C392()	100	250

*1: Ripple current (100 kHz / +105 °C)

*2: Impedance (100 kHz / +20 °C)

• When requesting taped product, please put the letter "B" or "H" between the "()".

Lead wire pitch *B=5 mm, 7.5 mm, H=2.5 mm.

• Please refer to the page of "Taping dimensions".

Characteristics list

Rated voltage (V)	Capacitance (±20 %) (μF)	Case size (mm)		Specification			Lead length (mm)				Part No.	Min. Packaging Q'ty (PCS)	
		øD	L	Ripple current ^{*1} (mA rms)	Impe-dance ^{*2} (Ω)	Endu-rance (h)	Lead dia. (ød)	Lead space				Straight leads	Taping
								Straight	Taping *B	Taping *H			
25	47	5.0	11.0	280	0.300	2000	0.5	2.0	5.0	2.5	EEUFM1E470()	200	2000
	100	6.3	11.2	455	0.130	2000	0.5	2.5	5.0	2.5	EEUFM1E101()	200	2000
	220	8.0	11.5	950	0.056	3000	0.6	3.5	5.0	—	EEUFM1E221()	200	1000
	330	8.0	15.0	1240	0.041	3000	0.6	3.5	5.0	—	EEUFM1E331L()	200	1000
		10.0	12.5	1290	0.038	4000	0.6	5.0	5.0	—	EEUFM1E331()	200	500
	470	8.0	20.0	1560	0.030	4000	0.6	3.5	5.0	—	EEUFM1E471L()	200	1000
		10.0	16.0	1790	0.026	4000	0.6	5.0	5.0	—	EEUFM1E471()	200	500
	680	10.0	20.0	2180	0.019	5000	0.6	5.0	5.0	—	EEUFM1E681()	200	500
	820	10.0	25.0	2470	0.018	5000	0.6	5.0	5.0	—	EEUFM1E821L()	200	500
	1000	12.5	20.0	2600	0.018	5000	0.6	5.0	5.0	—	EEUFM1E102()	200	500
	1500	12.5	25.0	3190	0.015	7000	0.6	5.0	5.0	—	EEUFM1E152()	200	500
	1800	12.5	30.0	3630	0.013	7000	0.8	5.0	—	—	EEUFM1E182L	100	—
		16.0	20.0	3300	0.017	5000	0.8	7.5	7.5	—	EEUFM1E182S()	100	250
2200	12.5	35.0	3750	0.012	7000	0.8	5.0	—	—	EEUFM1E222L	100	—	
2700	16.0	25.0	3820	0.014	7000	0.8	7.5	7.5	—	EEUFM1E272()	100	250	
35	33	5.0	11.0	280	0.300	2000	0.5	2.0	5.0	2.5	EEUFM1V330()	200	2000
	68	6.3	11.2	455	0.130	2000	0.5	2.5	5.0	2.5	EEUFM1V680()	200	2000
	150	8.0	11.5	950	0.056	3000	0.6	3.5	5.0	—	EEUFM1V151()	200	1000
	220	8.0	15.0	1240	0.041	3000	0.6	3.5	5.0	—	EEUFM1V221L()	200	1000
		10.0	12.5	1290	0.038	4000	0.6	5.0	5.0	—	EEUFM1V221()	200	500
	330	8.0	20.0	1560	0.030	4000	0.6	3.5	5.0	—	EEUFM1V331L()	200	1000
		10.0	16.0	1790	0.026	4000	0.6	5.0	5.0	—	EEUFM1V331()	200	500
	470	10.0	20.0	2180	0.019	5000	0.6	5.0	5.0	—	EEUFM1V471()	200	500
	560	10.0	25.0	2470	0.018	5000	0.6	5.0	5.0	—	EEUFM1V561L()	200	500
	680	12.5	20.0	2600	0.018	5000	0.6	5.0	5.0	—	EEUFM1V681()	200	500
	1000	12.5	25.0	3190	0.015	7000	0.6	5.0	5.0	—	EEUFM1V102()	200	500
	1200	12.5	30.0	3630	0.013	7000	0.8	5.0	—	—	EEUFM1V122L	100	—
		16.0	20.0	3300	0.017	5000	0.8	7.5	7.5	—	EEUFM1V122S()	100	250
1500	12.5	35.0	3750	0.012	7000	0.8	5.0	—	—	EEUFM1V152L	100	—	
1800	16.0	25.0	3820	0.014	7000	0.8	7.5	7.5	—	EEUFM1V182()	100	250	
50	22	5.0	11.0	250	0.340	2000	0.5	2.0	5.0	2.5	EEUFM1H220()	200	2000
	56	6.3	11.2	405	0.140	2000	0.5	2.5	5.0	2.5	EEUFM1H560()	200	2000
	100	8.0	11.5	870	0.061	3000	0.6	3.5	5.0	—	EEUFM1H101()	200	1000
	120	8.0	15.0	1140	0.045	3000	0.6	3.5	5.0	—	EEUFM1H121L()	200	1000
	150	10.0	12.5	1170	0.042	4000	0.6	5.0	5.0	—	EEUFM1H151()	200	500
	180	8.0	20.0	1430	0.033	4000	0.6	3.5	5.0	—	EEUFM1H181L()	200	1000
	220	10.0	16.0	1650	0.030	4000	0.6	5.0	5.0	—	EEUFM1H221()	200	500
	270	10.0	20.0	1890	0.023	5000	0.6	5.0	5.0	—	EEUFM1H271()	200	500
	330	10.0	25.0	2150	0.022	5000	0.6	5.0	5.0	—	EEUFM1H331L()	200	500
	470	12.5	20.0	2260	0.022	5000	0.6	5.0	5.0	—	EEUFM1H471()	200	500
	560	12.5	25.0	2660	0.018	7000	0.6	5.0	5.0	—	EEUFM1H561()	200	500
	680	12.5	30.0	3160	0.016	7000	0.8	5.0	—	—	EEUFM1H681L	100	—
	820	12.5	35.0	3270	0.014	7000	0.8	5.0	—	—	EEUFM1H821L	100	—
16.0		20.0	2870	0.019	5000	0.8	7.5	7.5	—	EEUFM1H821S()	100	250	
1000	16.0	25.0	3320	0.016	7000	0.8	7.5	7.5	—	EEUFM1H102()	100	250	

*1: Ripple current (100 kHz / +105 °C)

*2: Impedance (100 kHz / +20 °C)

• When requesting taped product, please put the letter "B" or "H" between the "()".

Lead wire pitch *B=5 mm, 7.5 mm, H=2.5 mm.

• Please refer to the page of "Taping dimensions".



This Series is no longer available for purchase in the country of Japan.



Radial Lead Type

EB-A series

Features

- Endurance : 105 °C 5000 h to 10000 h
- High ripple high frequency (High voltage)
- RoHS compliant

Specifications

Category temp. range	-40 °C to +105 °C	-25 °C to +105 °C
Rated voltage range	10 V to 63 V	160 V to 450 V
Capacitance range	2.2 μF to 3300 μF	10 μF to 330 μF
Capacitance tolerance	±20 % (120 Hz / +20°C)	
Leakage current	$I \leq 0.01 CV$ or $3 (\mu A)$ After 2 minutes (Whichever is greater)	$I \leq 0.06 CV + 10 (\mu A)$ After 2 minutes
Dissipation factor (tan δ)	Please see the attached characteristics list	
Endurance	After following life test with DC voltage and +105 °C±2 °C ripple current value applied (The sum of DC and ripple peak voltage shall not exceed the rated working voltage), when the capacitors are restored to 20 °C, the capacitors shall meet the limits specified bellow.	
	(10 V to 63 V) Duration : $\phi 5 \times 11$ to $\phi 8 \times 11.5$: 5000 h, $\phi 8 \times 15$ to $\phi 12.5 \times 25$: 10000 h	
	Capacitance change	Within ±30 % of the initial value
	Dissipation factor (tan δ)	≤ 300 % of the initial limit
	DC leakage current	Within the initial limit
	(160 V to 450 V) Duration : 5000 h	
Shelf life	After storage for 1000 h at +105 °C±2 °C with no voltage applied and then being stabilized at +20 °C, capacitors shall meet the limits specified in endurance. (With voltage treatment)	
	Capacitance change	Within ±20 % of the initial value
	Dissipation factor (tan δ)	≤ 200 % of the initial limit
	DC leakage current	Within the initial limit

Frequency correction factor for ripple current

■ 10 V to 63 V

Freq.(Hz) Cap.(μF)	60	120	1 k	10 k	100 k
2.2 to 10	0.75	1.00	1.40	1.55	1.65
22 to 470	0.85	1.00	1.20	1.25	1.30
1000 to 3300	0.95	1.00	1.05	1.10	1.15

■ 160 V to 450 V

Freq.(Hz) R. volt.(V)	120	1 k	10k to 30k	30k to 100k
160 to 250	0.55	0.85	0.90	1.00
350 to 450	0.50	0.80	0.90	1.00

Dimensions

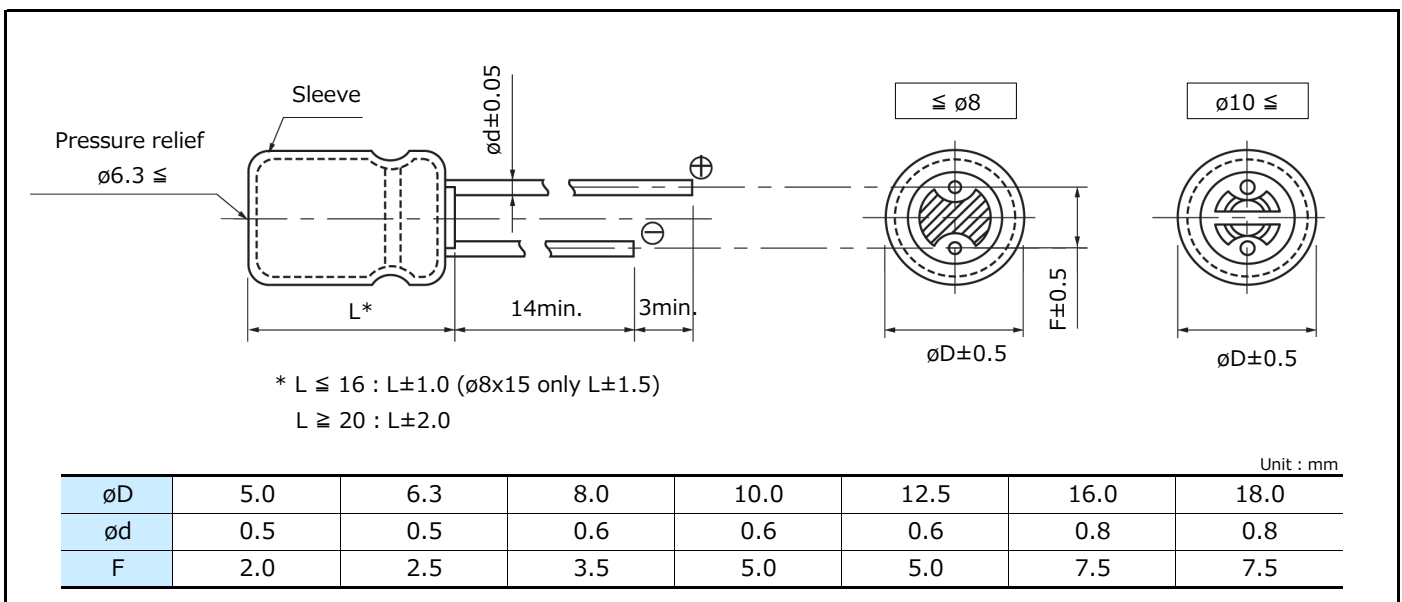

Characteristics list

Endurance : 105 °C 5000 h / $\phi 5 \times 11$ to $\phi 8 \times 11.5$, 105 °C 10000 h / $\phi 8 \times 15$ to $\phi 12.5 \times 25$

Rated voltage (V)	Capacitance ($\pm 20\%$) (μF)	Case size (mm)		Specification			Lead length (mm)				Part No.	Min. Packaging Q'ty (PCS)	
		ϕD	L	Ripple current* ¹ (mA rms)	$\tan \delta$ * ²	Endurance (h)	Lead dia. (ϕd)	Lead space				Straight leads	Taping
								Straight	Taping *B	Taping *H			
10	100	5.0	11.0	66	0.30	5000	0.5	2.0	5.0	2.5	EEUEB1A101S()	200	2000
	220	6.3	11.2	100	0.30	5000	0.5	2.5	5.0	2.5	EEUEB1A221S()	200	2000
	470	8.0	15.0	278	0.30	10000	0.6	3.5	5.0	—	EEUEB1A471()	200	1000
		8.0	11.5	180	0.30	5000	0.6	3.5	5.0	—	EEUEB1A471S()	200	1000
	2200	12.5	20.0	540	0.32	10000	0.6	5.0	5.0	—	EEUEB1A222()	200	500
	3300	12.5	25.0	802	0.34	10000	0.6	5.0	5.0	—	EEUEB1A332()	200	500
16	1000	10.0	20.0	430	0.25	10000	0.6	5.0	5.0	—	EEUEB1C102()	200	500
	2200	12.5	25.0	706	0.27	10000	0.6	5.0	5.0	—	EEUEB1C222()	200	500
25	47	5.0	11.0	55	0.22	5000	0.5	2.0	5.0	2.5	EEUEB1E470S()	200	2000
	100	6.3	11.2	95	0.22	5000	0.5	2.5	5.0	2.5	EEUEB1E101S()	200	2000
	220	8.0	11.5	125	0.22	5000	0.6	3.5	5.0	—	EEUEB1E221S()	200	1000
	330	8.0	15.0	255	0.22	10000	0.6	3.5	5.0	—	EEUEB1E331()	200	1000
	470	10.0	16.0	321	0.22	10000	0.6	5.0	5.0	—	EEUEB1E471()	200	500
	1000	12.5	20.0	498	0.22	10000	0.6	5.0	5.0	—	EEUEB1E102()	200	500
35	33	5.0	11.0	46	0.18	5000	0.5	2.0	5.0	2.5	EEUEB1V330S()	200	2000
	220	8.0	15.0	197	0.18	10000	0.6	3.5	5.0	—	EEUEB1V221()	200	1000
	330	10.0	16.0	278	0.18	10000	0.6	5.0	5.0	—	EEUEB1V331()	200	500
	470	10.0	20.0	349	0.18	10000	0.6	5.0	5.0	—	EEUEB1V471()	200	500
	1000	12.5	25.0	586	0.18	10000	0.6	5.0	5.0	—	EEUEB1V102()	200	500
50	2.2	5.0	11.0	15	0.15	5000	0.5	2.0	5.0	2.5	EEUEB1H2R2S()	200	2000
	3.3	5.0	11.0	18	0.15	5000	0.5	2.0	5.0	2.5	EEUEB1H3R3S()	200	2000
	4.7	5.0	11.0	18	0.15	5000	0.5	2.0	5.0	2.5	EEUEB1H4R7S()	200	2000
	10	5.0	11.0	27	0.15	5000	0.5	2.0	5.0	2.5	EEUEB1H100S()	200	2000
	22	5.0	11.0	39	0.15	5000	0.5	2.0	5.0	2.5	EEUEB1H220S()	200	2000
	47	6.3	11.2	61	0.15	5000	0.5	2.5	5.0	2.5	EEUEB1H470S()	200	2000
	100	8.0	11.5	99	0.15	5000	0.6	3.5	5.0	—	EEUEB1H101S()	200	1000
	220	10.0	16.0	234	0.15	10000	0.6	5.0	5.0	—	EEUEB1H221()	200	500
	330	10.0	20.0	293	0.15	10000	0.6	5.0	5.0	—	EEUEB1H331()	200	500
	470	12.5	20.0	370	0.15	10000	0.6	5.0	5.0	—	EEUEB1H471()	200	500
63	2.2	5.0	11.0	16.5	0.12	5000	0.5	2.0	5.0	2.5	EEUEB1J2R2S()	200	2000
	3.3	5.0	11.0	20	0.12	5000	0.5	2.0	5.0	2.5	EEUEB1J3R3S()	200	2000
	4.7	5.0	11.0	23	0.12	5000	0.5	2.0	5.0	2.5	EEUEB1J4R7S()	200	2000
	10	5.0	11.0	30	0.12	5000	0.5	2.0	5.0	2.5	EEUEB1J100S()	200	2000
	22	6.3	11.2	40	0.12	5000	0.5	2.5	5.0	2.5	EEUEB1J220S()	200	2000
	33	6.3	11.2	50	0.12	5000	0.5	2.5	5.0	2.5	EEUEB1J330S()	200	2000
	47	8.0	15.0	94	0.12	10000	0.6	3.5	5.0	—	EEUEB1J470()	200	1000
		8.0	11.5	80	0.12	5000	0.6	3.5	5.0	—	EEUEB1J470S()	200	1000
	100	8.0	15.0	180	0.12	10000	0.6	3.5	5.0	—	EEUEB1J101()	200	1000
	220	10.0	20.0	292	0.12	10000	0.6	5.0	5.0	—	EEUEB1J221()	200	500
	330	12.5	20.0	381	0.12	10000	0.6	5.0	5.0	—	EEUEB1J331()	200	500
	470	12.5	25.0	454	0.12	10000	0.6	5.0	5.0	—	EEUEB1J471()	200	500

*1: Ripple current (120 Hz / +105 °C)

*2: $\tan \delta$ (120 Hz / +20 °C)

• When requesting taped product, please put the letter "B" or "H" between the "()".

• Lead wire pitch *B=5 mm, H=2.5 mm.

• Please refer to the page of "Taping dimensions".

Characteristics list

Endurance : 105 °C 5000 h

Rated voltage (V)	Capacitance (±20 %) (μF)	Case size (mm)		Specification			Lead length (mm)			Part No.	Min. Packaging Q'ty (PCS)		
		øD	L	Ripple current* ¹ (mA rms)	tan δ* ²	Endurance (h)	Lead dia. (ød)	Lead space			Straight leads	Taping	
								Straight	Taping *B				
160	22	10.0	20.0	470	0.15	5000	0.6	5.0	5.0	EEUEB2C220()	200	500	
	33	10.0	20.0	470	0.15	5000	0.6	5.0	5.0	EEUEB2C330()	200	500	
	47	12.5	20.0	600	0.15	5000	0.6	5.0	5.0	EEUEB2C470()	200	500	
	68	12.5	25.0	750	0.15	5000	0.6	5.0	5.0	EEUEB2C680()	200	500	
		16.0	20.0	750	0.15	5000	0.8	7.5	7.5	EEUEB2C680S()	100	250	
	100	16.0	25.0	1060	0.15	5000	0.8	7.5	7.5	EEUEB2C101()	100	250	
		18.0	20.0	1060	0.15	5000	0.8	7.5	7.5	EEUEB2C101S()	100	250	
	150	16.0	31.5	1280	0.15	5000	0.8	7.5	—	EEUEB2C151	100	—	
		18.0	25.0	1280	0.15	5000	0.8	7.5	7.5	EEUEB2C151S()	100	250	
	220	16.0	31.5	1280	0.15	5000	0.8	7.5	—	EEUEB2C221	100	—	
		18.0	25.0	1280	0.15	5000	0.8	7.5	7.5	EEUEB2C221S()	100	250	
	330	18.0	31.5	1690	0.15	5000	0.8	7.5	—	EEUEB2C331	50	—	
200	22	10.0	20.0	470	0.15	5000	0.6	5.0	5.0	EEUEB2D220()	200	500	
	33	12.5	20.0	600	0.15	5000	0.6	5.0	5.0	EEUEB2D330()	200	500	
	47	12.5	20.0	600	0.15	5000	0.6	5.0	5.0	EEUEB2D470()	200	500	
	68	12.5	25.0	750	0.15	5000	0.6	5.0	5.0	EEUEB2D680()	200	500	
		16.0	20.0	750	0.15	5000	0.8	7.5	7.5	EEUEB2D680S()	100	250	
	100	16.0	25.0	1060	0.15	5000	0.8	7.5	7.5	EEUEB2D101()	100	250	
		18.0	20.0	1060	0.15	5000	0.8	7.5	7.5	EEUEB2D101S()	100	250	
	150	16.0	31.5	1280	0.15	5000	0.8	7.5	—	EEUEB2D151	100	—	
		18.0	25.0	1280	0.15	5000	0.8	7.5	7.5	EEUEB2D151S()	100	250	
	220	18.0	31.5	1690	0.15	5000	0.8	7.5	—	EEUEB2D221	50	—	
	250	22	12.5	20.0	560	0.15	5000	0.6	5.0	5.0	EEUEB2E220()	200	500
		33	12.5	20.0	560	0.15	5000	0.6	5.0	5.0	EEUEB2E330()	200	500
47		12.5	25.0	710	0.15	5000	0.6	5.0	5.0	EEUEB2E470()	200	500	
		16.0	20.0	710	0.15	5000	0.8	7.5	7.5	EEUEB2E470S()	100	250	
68		16.0	25.0	990	0.15	5000	0.8	7.5	7.5	EEUEB2E680()	100	250	
		18.0	20.0	990	0.15	5000	0.8	7.5	7.5	EEUEB2E680S()	100	250	
100		16.0	31.5	1200	0.15	5000	0.8	7.5	—	EEUEB2E101	100	—	
		18.0	25.0	1200	0.15	5000	0.8	7.5	7.5	EEUEB2E101S()	100	250	
150		18.0	31.5	1470	0.15	5000	0.8	7.5	—	EEUEB2E151	50	—	
350		10	10.0	20.0	270	0.20	5000	0.6	5.0	5.0	EEUEB2V100()	200	500
		22	12.5	20.0	350	0.20	5000	0.6	5.0	5.0	EEUEB2V220()	200	500
		33	16.0	20.0	480	0.20	5000	0.8	7.5	7.5	EEUEB2V330S()	100	250
	47	16.0	25.0	640	0.20	5000	0.8	7.5	7.5	EEUEB2V470()	100	250	
		18.0	20.0	640	0.20	5000	0.8	7.5	7.5	EEUEB2V470S()	100	250	
	68	16.0	31.5	780	0.20	5000	0.8	7.5	—	EEUEB2V680	100	—	
		18.0	25.0	780	0.20	5000	0.8	7.5	7.5	EEUEB2V680S()	100	250	
	100	18.0	31.5	970	0.20	5000	0.8	7.5	—	EEUEB2V101	50	—	
	400	10	10.0	20.0	250	0.24	5000	0.6	5.0	5.0	EEUEB2G100()	200	500
		22	12.5	25.0	410	0.24	5000	0.6	5.0	5.0	EEUEB2G220()	200	500
			16.0	20.0	410	0.24	5000	0.8	7.5	7.5	EEUEB2G220S()	100	250
		33	16.0	25.0	600	0.24	5000	0.8	7.5	7.5	EEUEB2G330()	100	250
18.0			20.0	600	0.24	5000	0.8	7.5	7.5	EEUEB2G330S()	100	250	
47		16.0	31.5	730	0.24	5000	0.8	7.5	—	EEUEB2G470	100	—	
		18.0	25.0	730	0.24	5000	0.8	7.5	7.5	EEUEB2G470S()	100	250	
450		10	12.5	20.0	310	0.24	5000	0.6	5.0	5.0	EEUEB2W100()	200	500
		22	16.0	25.0	560	0.24	5000	0.8	7.5	7.5	EEUEB2W220()	100	250
			18.0	20.0	560	0.24	5000	0.8	7.5	7.5	EEUEB2W220S()	100	250
		33	16.0	31.5	680	0.24	5000	0.8	7.5	—	EEUEB2W330()	100	—
			18.0	25.0	680	0.24	5000	0.8	7.5	7.5	EEUEB2W330S()	100	250
	47	18.0	31.5	850	0.24	5000	0.8	7.5	—	EEUEB2W470	50	—	

*1: Ripple current (100 kHz / +105 °C)

*2: tan δ (120 Hz / +20 °C)

- When requesting taped product, please put the letter "B" between the "()".
Lead wire pitch *B=5 mm.
- Please refer to the page of "Taping dimensions".



This Series is no longer available for purchase in the country of Japan.



Radial Lead Type

EE-A series

Features

- Endurance : 105 °C 8000 h to 10000 h
- High ripple current (at high frequency) : 40 % higher than ED series
- RoHS compliant

Specifications

Category temp. range	-25 °C to +105 °C							
Rated voltage range	160 V to 450 V							
Capacitance range	10 μF to 330 μF							
Capacitance tolerance	±20 % (120 Hz / +20°C)							
Leakage current	$I \leq 0.06 CV + 10 (\mu A)$ After 2 minutes							
Dissipation factor (tan δ)	Rated voltage (V)	160	200	250	350	400	450	(120 Hz / +20°C)
	Dissipation factor (tan δ)	0.15	0.15	0.15	0.20	0.24	0.24	
Endurance	After following life test with DC voltage and +105 °C±2 °C ripple current value applied (The sum of DC and ripple peak voltage shall not exceed the rated working voltage), when the capacitors are restored to 20 °C, the capacitors shall meet the limits specified bellow.							
	ø10 : 8000 h ø12.5 to ø18 : 10000 h							
	Capacitance change	Within ±20 % of the initial value						
	Dissipation factor (tan δ)	≤ 200 % of the initial limit						
Shelf life	After storage for 1000 h at +105 °C±2 °C with no voltage applied and then being stabilized at +20 °C, capacitors shall meet the limits specified in endurance.							
	(With voltage treatment)							
DC leakage current		Within the initial limit						

Frequency correction factor for ripple current

Capacitance(μF) \ Freq.(Hz)	60	120	300	1 k	10 k	100 k
10 to 82	0.25	0.35	0.50	0.65	0.90	1.00
100 to 330	0.30	0.40	0.55	0.70	0.90	1.00

Dimensions

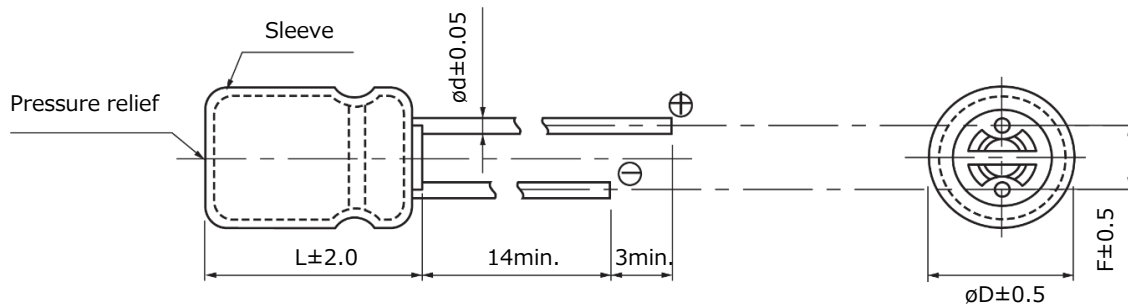

	Unit : mm			
øD	10.0	12.5	16.0	18.0
ød	0.6	0.6	0.8	0.8
F	5.0	5.0	7.5	7.5

Case size/Ripple current

Capacitance (μF)	160 V			200 V		
	Case size (mm) ($\phi\text{D}\times\text{L}$)	Ripple current (mA rms) (105 °C)		Case size (mm) ($\phi\text{D}\times\text{L}$)	Ripple current (mA rms) (105 °C)	
		120 Hz	100 kHz		120 Hz	100 kHz
22	10 × 20	245	700	10 × 20	300	850
33	10 × 20	280	810	10 × 20	320	920
47	10 × 20	370	1065	12.5 × 20	385	1100
68	12.5 × 20	470	1350	12.5 × 25	465	1330
				16 × 20S	465	1330
82	12.5 × 25	520	1480	16 × 20S	510	1460
100	12.5 × 25	660	1660	16 × 25	690	1730
	16 × 20S	680	1700	18 × 20S	670	1665
150	16 × 25	755	1890	16 × 25	740	1860
	18 × 20S	730	1820			
220	16 × 31.5	910	2280	18 × 31.5	1175	2600
	18 × 25S	780	1950			
330	18 × 31.5	1040	2600	18 × 40	1250	3120

Capacitance (μF)	250 V			350 V		
	Case size (mm) ($\phi\text{D}\times\text{L}$)	Ripple current (mA rms) (105 °C)		Case size (mm) ($\phi\text{D}\times\text{L}$)	Ripple current (mA rms) (105 °C)	
		120 Hz	100 kHz		120 Hz	100 kHz
15	—			10 × 20	170	480
22	10 × 20	275	785	12.5 × 20	230	660
33	12.5 × 20	350	995	12.5 × 25	275	790
				16 × 20S	315	900
47	12.5 × 25	450	1290	16 × 25	375	1070
	16 × 20S	490	1400	18 × 20S	375	1070
68	16 × 20S	490	1400	16 × 31.5	535	1530
				18 × 25S	465	1330
82	16 × 25	590	1680	18 × 25S	535	1530
	18 × 20S	590	1680			
100	16 × 31.5	840	2100	18 × 31.5	640	1600
	18 × 25S	840	2100			
150	18 × 31.5	1010	2520	—	—	—
220	18 × 40	1175	2940	—	—	—

Capacitance (μF)	400 V			450 V		
	Case size (mm) ($\phi\text{D}\times\text{L}$)	Ripple current (mA rms) (105 °C)		Case size (mm) ($\phi\text{D}\times\text{L}$)	Ripple current (mA rms) (105 °C)	
		120 Hz	100 kHz		120 Hz	100 kHz
10	10 × 20	150	430	10 × 20U	115	330
				12.5 × 20	170	490
15	12.5 × 20	205	590	12.5 × 25	270	780
22	12.5 × 25	265	760	16 × 20S	330	945
	16 × 20S	300	860			
33	16 × 20S	355	1020	16 × 25	350	1000
				18 × 20S	350	1000
47	16 × 25	410	1180	16 × 31.5	420	1200
	18 × 20S	410	1180	18 × 25S	420	1200
56	—	—	—	18 × 31.5	480	1380
68	18 × 25	515	1470	18 × 40	630	1800
82	18 × 31.5	575	1645	—	—	—
100	18 × 40	825	2060	—	—	—

Characteristics list

Endurance : 105 °C 8000 h / ϕ 10, 105 °C 10000 h / ϕ 12.5 to ϕ 18

Rated voltage (V)	Capacitance ($\pm 20\%$) (μ F)	Case size (mm)		Specification			Lead length (mm)			Part No.	Min. Packaging Q'ty (PCS)	
		ϕ D	L	Ripple current* ¹ (mA rms)	tan δ * ²	Endurance (h)	Lead dia. (ϕ d)	Lead space			Straight leads	Taping
								Straight	Taping *B			
160	22	10.0	20.0	700	0.15	8000	0.6	5.0	5.0	EEUEE2C220()	200	500
	33	10.0	20.0	810	0.15	8000	0.6	5.0	5.0	EEUEE2C330()	200	500
	47	10.0	20.0	1065	0.15	8000	0.6	5.0	5.0	EEUEE2C470()	200	500
	68	12.5	20.0	1350	0.15	10000	0.6	5.0	5.0	EEUEE2C680()	200	500
	82	12.5	25.0	1480	0.15	10000	0.6	5.0	5.0	EEUEE2C820()	200	500
	100	12.5	25.0	1660	0.15	10000	0.6	5.0	5.0	EEUEE2C101()	200	500
		16.0	20.0	1700	0.15	10000	0.8	7.5	7.5	EEUEE2C101S()	100	250
	150	16.0	25.0	1890	0.15	10000	0.8	7.5	7.5	EEUEE2C151()	100	250
		18.0	20.0	1820	0.15	10000	0.8	7.5	7.5	EEUEE2C151S()	100	250
	220	16.0	31.5	2280	0.15	10000	0.8	7.5	—	EEUEE2C221	100	—
18.0		25.0	1950	0.15	10000	0.8	7.5	7.5	EEUEE2C221S()	100	250	
330	18.0	31.5	2600	0.15	10000	0.8	7.5	—	EEUEE2C331	50	—	
200	22	10.0	20.0	850	0.15	8000	0.6	5.0	5.0	EEUEE2D220()	200	500
	33	10.0	20.0	920	0.15	8000	0.6	5.0	5.0	EEUEE2D330()	200	500
	47	12.5	20.0	1100	0.15	10000	0.6	5.0	5.0	EEUEE2D470()	200	500
	68	12.5	25.0	1330	0.15	10000	0.6	5.0	5.0	EEUEE2D680()	200	500
		16.0	20.0	1330	0.15	10000	0.8	7.5	7.5	EEUEE2D680S()	100	250
	82	16.0	20.0	1460	0.15	10000	0.8	7.5	7.5	EEUEE2D820S()	100	250
	100	16.0	25.0	1730	0.15	10000	0.8	7.5	7.5	EEUEE2D101()	100	250
		18.0	20.0	1665	0.15	10000	0.8	7.5	7.5	EEUEE2D101S()	100	250
	150	16.0	25.0	1860	0.15	10000	0.8	7.5	7.5	EEUEE2D151()	100	250
	220	18.0	31.5	2600	0.15	10000	0.8	7.5	—	EEUEE2D221	50	—
330	18.0	40.0	3120	0.15	10000	0.8	7.5	—	EEUEE2D331	50	—	
250	22	10.0	20.0	785	0.15	8000	0.6	5.0	5.0	EEUEE2E220()	200	500
	33	12.5	20.0	995	0.15	10000	0.6	5.0	5.0	EEUEE2E330()	200	500
	47	12.5	25.0	1290	0.15	10000	0.6	5.0	5.0	EEUEE2E470()	200	500
		16.0	20.0	1400	0.15	10000	0.8	7.5	7.5	EEUEE2E470S()	100	250
	68	16.0	20.0	1400	0.15	10000	0.8	7.5	7.5	EEUEE2E680S()	100	250
	82	16.0	25.0	1680	0.15	10000	0.8	7.5	7.5	EEUEE2E820()	100	250
		18.0	20.0	1680	0.15	10000	0.8	7.5	7.5	EEUEE2E820S()	100	250
	100	16.0	31.5	2100	0.15	10000	0.8	7.5	—	EEUEE2E101	100	—
		18.0	25.0	2100	0.15	10000	0.8	7.5	7.5	EEUEE2E101S()	100	250
	150	18.0	31.5	2520	0.15	10000	0.8	7.5	—	EEUEE2E151	50	—
220	18.0	40.0	2940	0.15	10000	0.8	7.5	—	EEUEE2E221	50	—	
350	15	10.0	20.0	480	0.20	8000	0.6	5.0	5.0	EEUEE2V150()	200	500
	22	12.5	20.0	660	0.20	10000	0.6	5.0	5.0	EEUEE2V220()	200	500
	33	12.5	25.0	790	0.20	10000	0.6	5.0	5.0	EEUEE2V330()	200	500
		16.0	20.0	900	0.20	10000	0.8	7.5	7.5	EEUEE2V330S()	100	250
	47	16.0	25.0	1070	0.20	10000	0.8	7.5	7.5	EEUEE2V470()	100	250
		18.0	20.0	1070	0.20	10000	0.8	7.5	7.5	EEUEE2V470S()	100	250
	68	16.0	31.5	1530	0.20	10000	0.8	7.5	—	EEUEE2V680	100	—
		18.0	25.0	1330	0.20	10000	0.8	7.5	7.5	EEUEE2V680S()	100	250
	82	18.0	25.0	1530	0.20	10000	0.8	7.5	7.5	EEUEE2V820S()	100	250
	100	18.0	31.5	1600	0.20	10000	0.8	7.5	—	EEUEE2V101	50	—

*1: Ripple current (100 kHz / +105 °C)

*2: tan δ (120 Hz / +20 °C)

- When requesting taped product, please put the letter "B" between the "()".
Lead wire pitch *B=5 mm, 7.5 mm.
- Please refer to the page of "Taping dimensions".

Characteristics list

Endurance : 105 °C 8000 h / ϕ 10, 105 °C 10000 h / ϕ 12.5 to ϕ 18

Rated voltage (V)	Capacitance ($\pm 20\%$) (μF)	Case size (mm)		Specification			Lead length (mm)			Part No.	Min. Packaging Q'ty (PCS)	
		ϕD	L	Ripple current* ¹ (mA rms)	$\tan \delta$ * ²	Endurance (h)	Lead dia. (ϕd)	Lead space			Straight leads	Taping
								Straight	Taping *B			
400	10	10.0	20.0	430	0.24	8000	0.6	5.0	5.0	EEUEE2G100()	200	500
	15	12.5	20.0	590	0.24	10000	0.6	5.0	5.0	EEUEE2G150()	200	500
	22	12.5	25.0	760	0.24	10000	0.6	5.0	5.0	EEUEE2G220()	200	500
		16.0	20.0	860	0.24	10000	0.8	7.5	7.5	EEUEE2G220S()	100	250
	33	16.0	20.0	1020	0.24	10000	0.8	7.5	7.5	EEUEE2G330S()	100	250
	47	16.0	25.0	1180	0.24	10000	0.8	7.5	7.5	EEUEE2G470()	100	250
		18.0	20.0	1180	0.24	10000	0.8	7.5	7.5	EEUEE2G470S()	100	250
	68	18.0	25.0	1470	0.24	10000	0.8	7.5	7.5	EEUEE2G680()	100	250
	82	18.0	31.5	1645	0.24	10000	0.8	7.5	—	EEUEE2G820	50	—
100	18.0	40.0	2060	0.24	10000	0.8	7.5	—	EEUEE2G101	50	—	
450	10	10.0	20.0	330	0.24	8000	0.6	5.0	5.0	EEUEE2W100U()	200	500
		12.5	20.0	490	0.24	10000	0.6	5.0	5.0	EEUEE2W100()	200	500
	15	12.5	25.0	780	0.24	10000	0.6	5.0	5.0	EEUEE2W150()	200	500
	22	16.0	20.0	945	0.24	10000	0.8	7.5	7.5	EEUEE2W220S()	100	250
	33	16.0	25.0	1000	0.24	10000	0.8	7.5	7.5	EEUEE2W330()	100	250
		18.0	20.0	1000	0.24	10000	0.8	7.5	7.5	EEUEE2W330S()	100	250
	47	16.0	31.5	1200	0.24	10000	0.8	7.5	—	EEUEE2W470	100	—
		18.0	25.0	1200	0.24	10000	0.8	7.5	7.5	EEUEE2W470S()	100	250
	56	18.0	31.5	1380	0.24	10000	0.8	7.5	—	EEUEE2W560	50	—
68	18.0	40.0	1800	0.24	10000	0.8	7.5	—	EEUEE2W680	50	—	

*1: Ripple current (100 kHz / +105 °C)

*2: $\tan \delta$ (120 Hz / +20 °C)

• When requesting taped product, please put the letter "B" between the "()".

Lead wire pitch *B=5 mm, 7.5 mm.

• Please refer to the page of "Taping dimensions".



This Series is no longer available for purchase in the country of Japan.



Radial Lead Type

TA-A series

Features

- Endurance : 125 °C 2000 h
- Heat cycle: 1000 cycle -40 °C to +125 °C
- AEC-Q200 compliant
- RoHS compliant

Specifications

Category temp. range	-40 °C to +125 °C							
Rated voltage range	10 V to 63 V							
Capacitance range	2.2 μF to 4700 μF							
Capacitance tolerance	±20 % (120 Hz / +20°C)							
Leakage current	I ≤ 0.01 CV or 3 (μA) After 2 minutes (Whichever is greater)							
Dissipation factor (tan δ)	Rated voltage (V)	10	16	25	35	50	63	(120 Hz / +20°C)
	Dissipation factor (tan δ)	0.20	0.16	0.14	0.12	0.10	0.09	
For capacitance value ≥ 1000 μF , add 0.02 per every 1000 μF.								
Endurance	After following life test with DC voltage and +125 °C±2 °C ripple current value applied (The sum of DC and ripple peak voltage shall not exceed the rated working voltage) for 2000 h, when the capacitors are restored to 20 °C, the capacitors shall meet the limits specified bellow.							
	Capacitance change	Within ±30 % of the initial value						
	Dissipation factor (tan δ)	≤ 300 % of the initial limit						
	DC leakage current	Within the initial limit						
Shelf life	After storage for 1000 h at +125 °C±2 °C with no voltage applied and then being stabilized at +20 °C, capacitors shall meet the limits specified in endurance. (With voltage treatment)							

Frequency correction factor for ripple current

Freq. (Hz)	60	120	1 k	10 k	100 k
2.2 to 330	0.55	0.65	0.85	0.90	1.00
470 to 1000	0.70	0.75	0.90	0.95	1.00
2200 to 4700	0.75	0.80	0.90	0.95	1.00

Dimensions

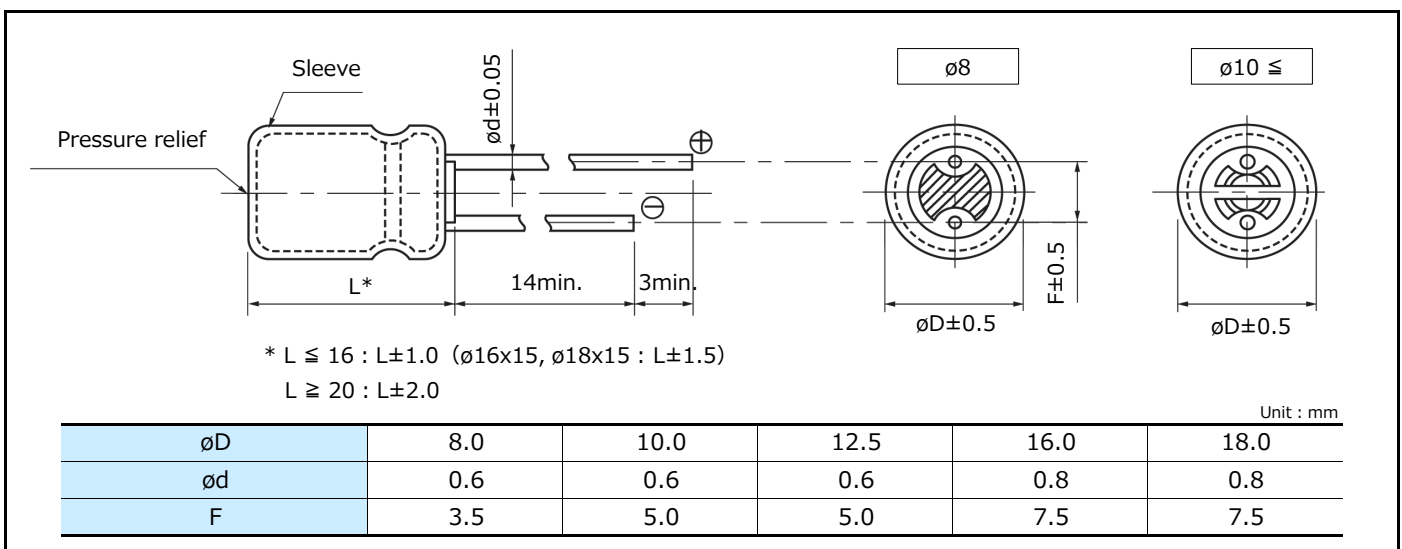

Characteristics list

Endurance : 125 °C 2000 h

Rated voltage (V)	Capacitance (±20 %) (μF)	Case size (mm)		Specification		Lead length (mm)			Part No.	Min. Packaging Q'ty (PCS)	
		øD	L	Ripple current*1 (mA rms)	Impe-dance*2 (Ω)	Lead dia. (ød)	Lead space			Strai-ght leads	Taping
							Straight	Taping *B			
10	330	8.0	11.5	500	0.130	0.6	3.5	5.0	EEUTA1A331()	200	1000
	470	10.0	12.5	680	0.100	0.6	5.0	5.0	EEUTA1A471()	200	500
	1000	10.0	20.0	1100	0.057	0.6	5.0	5.0	EEUTA1A102()	200	500
		12.5	15.0	1085	0.070	0.6	5.0	5.0	EEUTA1A102S()	200	500
	2200	12.5	25.0	1750	0.033	0.6	5.0	5.0	EEUTA1A222L()	200	500
		16.0	20.0	1985	0.032	0.8	7.5	7.5	EEUTA1A222()	100	250
		18.0	15.0	1800	0.042	0.8	7.5	7.5	EEUTA1A222S()	100	250
	3300	16.0	25.0	2300	0.024	0.8	7.5	7.5	EEUTA1A332()	100	250
		18.0	20.0	2250	0.031	0.8	7.5	7.5	EEUTA1A332S()	100	250
	4700	16.0	31.5	2710	0.020	0.8	7.5	—	EEUTA1A472	100	—
18.0		25.0	2470	0.022	0.8	7.5	7.5	EEUTA1A472S()	100	250	
16	220	8.0	11.5	500	0.130	0.6	3.5	5.0	EEUTA1C221()	200	1000
	330	10.0	12.5	680	0.100	0.6	5.0	5.0	EEUTA1C331()	200	500
	470	10.0	16.0	945	0.075	0.6	5.0	5.0	EEUTA1C471()	200	500
	1000	12.5	20.0	1490	0.042	0.6	5.0	5.0	EEUTA1C102()	200	500
		16.0	15.0	1520	0.047	0.8	7.5	7.5	EEUTA1C102S()	100	250
	2200	16.0	25.0	2300	0.024	0.8	7.5	7.5	EEUTA1C222()	100	250
		18.0	20.0	2250	0.031	0.8	7.5	7.5	EEUTA1C222S()	100	250
	3300	16.0	31.5	2710	0.020	0.8	7.5	—	EEUTA1C332	100	—
		18.0	25.0	2470	0.022	0.8	7.5	7.5	EEUTA1C332S()	100	250
	4700	18.0	31.5	3270	0.018	0.8	7.5	—	EEUTA1C472	50	—
25	100	8.0	11.5	500	0.130	0.6	3.5	5.0	EEUTA1E101()	200	1000
	220	10.0	12.5	680	0.100	0.6	5.0	5.0	EEUTA1E221()	200	500
	330	10.0	16.0	945	0.075	0.6	5.0	5.0	EEUTA1E331()	200	500
	470	10.0	20.0	1100	0.057	0.6	5.0	5.0	EEUTA1E471()	200	500
		12.5	15.0	1085	0.070	0.6	5.0	5.0	EEUTA1E471S()	200	500
	1000	12.5	25.0	1750	0.033	0.6	5.0	5.0	EEUTA1E102L()	200	500
		16.0	20.0	1985	0.032	0.8	7.5	7.5	EEUTA1E102()	100	250
		18.0	15.0	1800	0.042	0.8	7.5	7.5	EEUTA1E102S()	100	250
	2200	16.0	31.5	2710	0.020	0.8	7.5	—	EEUTA1E222	100	—
		18.0	25.0	2470	0.022	0.8	7.5	7.5	EEUTA1E222S()	100	250
3300	18.0	35.5	3310	0.017	0.8	7.5	—	EEUTA1E332	50	—	
35	100	10.0	12.5	555	0.180	0.6	5.0	5.0	EEUTA1V101()	200	500
	220	10.0	16.0	765	0.130	0.6	5.0	5.0	EEUTA1V221()	200	500
	330	10.0	20.0	930	0.100	0.6	5.0	5.0	EEUTA1V331()	200	500
	470	12.5	20.0	1330	0.070	0.6	5.0	5.0	EEUTA1V471()	200	500
		16.0	15.0	1450	0.088	0.8	7.5	7.5	EEUTA1V471S()	100	250
	1000	16.0	25.0	2010	0.037	0.8	7.5	7.5	EEUTA1V102()	100	250
		18.0	20.0	2180	0.046	0.8	7.5	7.5	EEUTA1V102S()	100	250
	2200	18.0	35.5	2790	0.025	0.8	7.5	—	EEUTA1V222	50	—

*1: Ripple current (100 kHz / +125 °C)

*2: Impedance (100 kHz / +20 °C)

• When requesting taped product, please put the letter "B" between the "()".

Lead wire pitch *B=5 mm, 7.5 mm.

• Please refer to the page of "Taping dimensions".

Characteristics list

Endurance : 125 °C 2000 h

Rated voltage (V)	Capacitance (±20 %) (µF)	Case size (mm)		Specification		Lead length (mm)			Part No.	Min. Packaging Q'ty (PCS)	
		øD	L	Ripple current*1 (mA rms)	Impe-dance*2 (Ω)	Lead dia. (ød)	Lead space			Straight leads	Taping
							Straight	Taping *B			
50	10	8.0	11.5	180	0.950	0.6	3.5	5.0	EEUTA1H100()	200	1000
	22	8.0	11.5	250	0.650	0.6	3.5	5.0	EEUTA1H220()	200	1000
	33	8.0	11.5	300	0.450	0.6	3.5	5.0	EEUTA1H330()	200	1000
	47	8.0	11.5	440	0.350	0.6	3.5	5.0	EEUTA1H470S()	200	1000
	100	10.0	12.5	555	0.180	0.6	5.0	5.0	EEUTA1H101()	200	500
	220	10.0	20.0	930	0.100	0.6	5.0	5.0	EEUTA1H221()	200	500
	330	12.5	20.0	1330	0.070	0.6	5.0	5.0	EEUTA1H331()	200	500
		16.0	15.0	1450	0.088	0.8	7.5	7.5	EEUTA1H331S()	100	250
	470	12.5	25.0	1650	0.055	0.6	5.0	5.0	EEUTA1H471L()	200	500
		16.0	20.0	1650	0.053	0.8	7.5	7.5	EEUTA1H471()	100	250
	1000	18.0	15.0	1710	0.075	0.8	7.5	7.5	EEUTA1H471S()	100	250
		16.0	31.5	2430	0.031	0.8	7.5	—	EEUTA1H102	100	—
	18.0	25.0	2350	0.032	0.8	7.5	7.5	EEUTA1H102S()	100	250	
63	22	8.0	11.5	310	0.470	0.6	3.5	5.0	EEUTA1J220()	200	1000
	33	10.0	12.5	410	0.360	0.6	5.0	5.0	EEUTA1J330()	200	500
	47	10.0	16.0	460	0.270	0.6	5.0	5.0	EEUTA1J470()	200	500
	100	10.0	20.0	680	0.205	0.6	5.0	5.0	EEUTA1J101()	200	500
	220	12.5	25.0	1325	0.100	0.6	5.0	5.0	EEUTA1J221L()	200	500
		16.0	20.0	1360	0.085	0.8	7.5	7.5	EEUTA1J221()	100	250
		18.0	15.0	1300	0.120	0.8	7.5	7.5	EEUTA1J221S()	100	250
	330	16.0	25.0	1660	0.070	0.8	7.5	7.5	EEUTA1J331()	100	250
		18.0	20.0	1760	0.077	0.8	7.5	7.5	EEUTA1J331S()	100	250
	470	16.0	31.5	2055	0.060	0.8	7.5	—	EEUTA1J471	100	—
		18.0	25.0	1990	0.060	0.8	7.5	7.5	EEUTA1J471S()	100	250

*1: Ripple current (100 kHz / +125 °C)

*2: Impedance (100 kHz / +20 °C)

• When requesting taped product, please put the letter "B" between the "()".

Lead wire pitch *B=5 mm, 7.5 mm.

• Please refer to the page of "Taping dimensions".



This Series is no longer available for purchase in the country of Japan.



Radial Lead Type

TP-A series

Features

- Endurance : 125 °C 2000 h to 5000 h or 135 °C 1000 h to 2000 h
- Smaller than series TA
- High ripple current (at high frequency) : 20 to 40% higher than TA series
- AEC-Q200 compliant
- RoHS compliant

Specifications

Category temp. range	-40 °C to +135 °C		
Rated voltage range	25 V to 35 V		
Capacitance range	100 µF to 5100 µF		
Capacitance tolerance	±20 % (120 Hz / +20°C)		
Leakage current	$I \leq 0.01 CV (\mu A)$ After 2 minutes		
Dissipation factor (tan δ)	Rated voltage (V)	25	35
	Dissipation factor (tan δ)	0.14	0.12
(120 Hz / +20°C)			
Endurance 1	For capacitance value $\geq 1000 \mu F$, add 0.02 per every 1000 µF.		
	After following life test with DC voltage and +125 °C±2 °C ripple current value applied (The sum of DC and ripple peak voltage shall not exceed the rated working voltage)when the capacitors are restored to 20 °C, the capacitors shall meet the limits specified bellow. Duration ø8 : 2000 h, ø10 : 3000 h, ø12.5 : 4000 h, ø16 to ø18 : 5000 h		
	Capacitance change	Within ±30 % of the initial value	
	Dissipation factor (tan δ)	≤ 300 % of the initial limit	
Endurance 2	After following life test with DC voltage and +135 °C±2 °C ripple current value applied (The sum of DC and ripple peak voltage shall not exceed the rated working voltage)when the capacitors are restored to 20 °C, the capacitors shall meet the limits specified bellow. Duration ø8: 1000 h, ø10 to ø18: 2000 h		
	Capacitance change	Within ±30 % of the initial value	
	Dissipation factor (tan δ)	≤ 300 % of the initial limit	
	DC leakage current	Within the initial limit	
Shelf life 1	After storage for 1000 h at +125 °C±2 °C with no voltage applied and then being stabilized at +20 °C, capacitors shall meet the limits specified in endurance. (With voltage treatment)		
Shelf life 2	After storage for 1000 h at +135 °C±2 °C with no voltage applied and then being stabilized at +20 °C, capacitors shall meet the limits specified in endurance. (With voltage treatment)		

Frequency correction factor for ripple current

Cap. (µF) \ Freq. (Hz)	60	120	1 k	10 k	100 k
100 to 330	0.55	0.65	0.85	0.90	1.00
390 to 1000	0.70	0.75	0.90	0.95	1.00
1200 to 5100	0.75	0.80	0.90	0.95	1.00

Dimensions

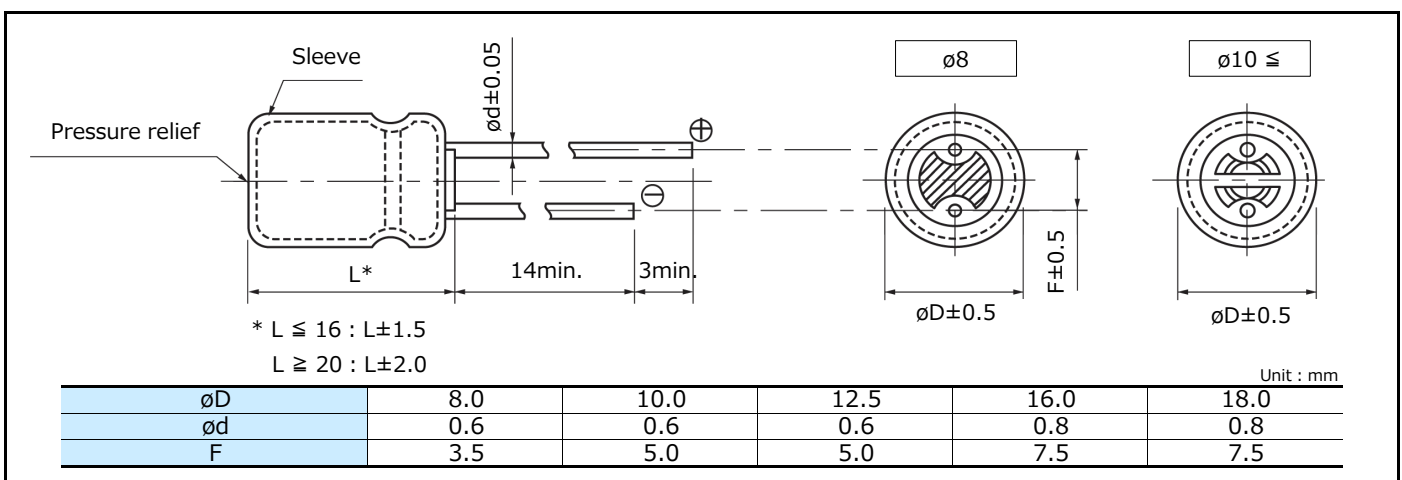

Characteristics list

Endurance : 125°C 2000 h / $\phi 8$, 125°C 3000 h / $\phi 10$, 125°C 4000 h / $\phi 12.5$, 125°C 5000 h / $\phi 16$ to $\phi 18$

Rated voltage (V)	Capacitance ($\pm 20\%$) (μF)	Case size (mm)		Specification						Lead length (mm)			Part No. ★:Substandard (E24 series numbers)	Min. Packaging Q'ty (PCS)	
				Ripple current* ¹ (mA rms)	ESR* ² (Ω)	$\tan \delta$ * ³	Endurance (h)		Lead dia. (ϕ)	Lead space		Straight		Taping *B	Straight leads
		125°C	135°C				125°C	135°C		ϕ D	L				
25	220	10.0	12.5	580	500	0.190	0.14	3000	2000	0.6	5.0	5.0	EEUTP1E221()	200	500
	330	10.0	16.0	1100	945	0.130	0.14	3000	2000	0.6	5.0	5.0	EEUTP1E331()	200	500
	470	8.0	20.0	1060	760	0.067	0.14	2000	1000	0.6	3.5	5.0	EEUTP1E471L()	200	1000
		10.0	16.0	1100	945	0.130	0.14	3000	2000	0.6	5.0	5.0	EEUTP1E471()	200	500
	510	10.0	16.0	1100	945	0.130	0.14	3000	2000	0.6	5.0	5.0	EEUTP1E511()★	200	500
	820	10.0	20.0	1540	1100	0.052	0.14	3000	2000	0.6	5.0	5.0	EEUTP1E821()	200	500
	1000	12.5	20.0	1860	1490	0.038	0.14	4000	2000	0.6	5.0	5.0	EEUTP1E102()	200	500
	1200	12.5	20.0	1860	1490	0.038	0.14	4000	2000	0.6	5.0	5.0	EEUTP1E122()	200	500
	1800	12.5	25.0	2180	1750	0.030	0.14	4000	2000	0.6	5.0	5.0	EEUTP1E182()	200	500
		16.0	20.0	2380	1985	0.029	0.14	5000	2000	0.8	7.5	7.5	EEUTP1E182S()	100	250
	2000	16.0	20.0	2380	1985	0.029	0.16	5000	2000	0.8	7.5	7.5	EEUTP1E202S()★	100	250
	2200	16.0	25.0	2760	2300	0.022	0.16	5000	2000	0.8	7.5	7.5	EEUTP1E222()	100	250
		18.0	20.0	2700	2250	0.028	0.16	5000	2000	0.8	7.5	7.5	EEUTP1E222S()	100	250
	2700	16.0	25.0	2760	2300	0.022	0.16	5000	2000	0.8	7.5	7.5	EEUTP1E272()	100	250
		18.0	20.0	2700	2250	0.028	0.16	5000	2000	0.8	7.5	7.5	EEUTP1E272S()	100	250
	3300	16.0	31.5	3250	2710	0.018	0.18	5000	2000	0.8	7.5	—	EEUTP1E332	100	—
		18.0	25.0	2960	2470	0.020	0.18	5000	2000	0.8	7.5	7.5	EEUTP1E332S()	100	250
	3900	16.0	31.5	3250	2710	0.018	0.18	5000	2000	0.8	7.5	—	EEUTP1E392	100	—
		18.0	25.0	2960	2470	0.020	0.18	5000	2000	0.8	7.5	7.5	EEUTP1E392S()	100	250
	4700	18.0	31.5	3480	2900	0.016	0.20	5000	2000	0.8	7.5	—	EEUTP1E472	50	—
5100	18.0	31.5	3480	2900	0.016	0.22	5000	2000	0.8	7.5	—	EEUTP1E512★	50	—	
35	100	10.0	12.5	580	500	0.190	0.12	3000	2000	0.6	5.0	5.0	EEUTP1V101()	200	500
	120	10.0	12.5	580	500	0.190	0.12	3000	2000	0.6	5.0	5.0	EEUTP1V121()	200	500
	220	8.0	20.0	1060	760	0.067	0.12	2000	1000	0.6	3.5	5.0	EEUTP1V221L()	200	1000
		10.0	16.0	1100	945	0.130	0.12	3000	2000	0.6	5.0	5.0	EEUTP1V221()	200	500
	270	8.0	16.0	1060	760	0.067	0.12	2000	1000	0.6	3.5	5.0	EEUTP1V271L()	200	1000
		10.0	16.0	1100	945	0.130	0.12	3000	2000	0.6	5.0	5.0	EEUTP1V271()	200	500
	330	10.0	20.0	1540	1100	0.052	0.12	3000	2000	0.6	5.0	5.0	EEUTP1V331()	200	500
	390	10.0	20.0	1540	1100	0.052	0.12	3000	2000	0.6	5.0	5.0	EEUTP1V391()	200	500
	470	12.5	20.0	1860	1490	0.038	0.12	4000	2000	0.6	5.0	5.0	EEUTP1V471()	200	500
	560	12.5	20.0	1860	1490	0.038	0.12	4000	2000	0.6	5.0	5.0	EEUTP1V561()	200	500
	620	12.5	20.0	1860	1490	0.038	0.12	4000	2000	0.6	5.0	5.0	EEUTP1V621()★	200	500
	820	12.5	25.0	2180	1750	0.030	0.12	4000	2000	0.6	5.0	5.0	EEUTP1V821()	200	500
	1000	16.0	20.0	2380	1985	0.029	0.12	5000	2000	0.8	7.5	7.5	EEUTP1V102()	100	250
	1200	16.0	20.0	2380	1985	0.029	0.12	5000	2000	0.8	7.5	7.5	EEUTP1V122()	100	250
	1500	16.0	25.0	2760	2300	0.022	0.12	5000	2000	0.8	7.5	7.5	EEUTP1V152()	100	250
		18.0	20.0	2700	2250	0.028	0.12	5000	2000	0.8	7.5	7.5	EEUTP1V152S()	100	250
	1600	16.0	25.0	2760	2300	0.022	0.12	5000	2000	0.8	7.5	7.5	EEUTP1V162()★	100	250
	1800	16.0	31.5	3250	2710	0.018	0.12	5000	2000	0.8	7.5	—	EEUTP1V182	100	—
		18.0	25.0	2960	2470	0.020	0.12	5000	2000	0.8	7.5	7.5	EEUTP1V182S()	100	250
	2000	16.0	31.5	3250	2710	0.018	0.14	5000	2000	0.8	7.5	—	EEUTP1V202★	100	—
18.0		25.0	2960	2470	0.020	0.14	5000	2000	0.8	7.5	7.5	EEUTP1V202S()★	100	250	
2200	18.0	31.5	3480	2900	0.016	0.14	5000	2000	0.8	7.5	—	EEUTP1V222	50	—	
2700	18.0	31.5	3480	2900	0.016	0.14	5000	2000	0.8	7.5	—	EEUTP1V272	50	—	

*1: Ripple current (100 kHz / +125 °C or 135 °C)

*2: ESR (100 kHz / +20 °C)

*3: $\tan \delta$ (120 Hz / +20 °C)

• When requesting taped product, please put the letter "B" between the "()".

Lead wire pitch *B=5 mm, 7.5 mm.

• Please refer to the page of "Taping dimensions".



This Series is no longer available for purchase in the country of Japan.



Radial Lead Type

HD-A series

Features

- Endurance : 105 °C 1000 h to 2000 h
- Minaturize, Higher Capacitance : 1 Size miniturized product of current A-NHG
- AEC-Q200 compliant
- RoHS compliant

Specifications

Category temp. range	-55 °C to +105 °C	
Rated voltage range	10 V to 50 V	
Capacitance range	2.2 μF to 22000 μF	
Capacitance tolerance	±20 % (120 Hz / +20°C)	
Leakage current	I ≤ 0.01 CV or 3 (μA) After 2 minutes (Whichever is greater)	
Dissipation factor (tan δ)	Please see the attached characteristics list	
Endurance	After following life test with DC voltage and +105 °C±2 °C ripple current value applied (The sum of DC and ripple peak voltage shall not exceed the rated working voltage)when the capacitors are restored to 20 °C, the capacitors shall meet the limits specified bellow. Duration ø5 to ø8 : 1000 h, ø10 to ø18 : 2000 h	
	Capacitance change	Within ±20 % of the initial value
	Dissipation factor (tan δ)	≤ 200 % of the initial limit
	DC leakage current	Within the initial limit
Shelf life	After storage for 1000 h at +105 °C±2 °C with no voltage applied and then being stabilized at +20 °C, capacitors shall meet the limits specified in endurance. (With voltage treatment)	

Frequency correction factor for ripple current

Cap. (μF) \ Freq. (Hz)	60	120	1 k	10 k	100 k
2.2 to 33	0.75	1.00	1.55	1.80	2.00
47 to 470	0.80	1.00	1.35	1.50	1.50
1000 to 22000	0.85	1.00	1.10	1.15	1.15

Dimensions

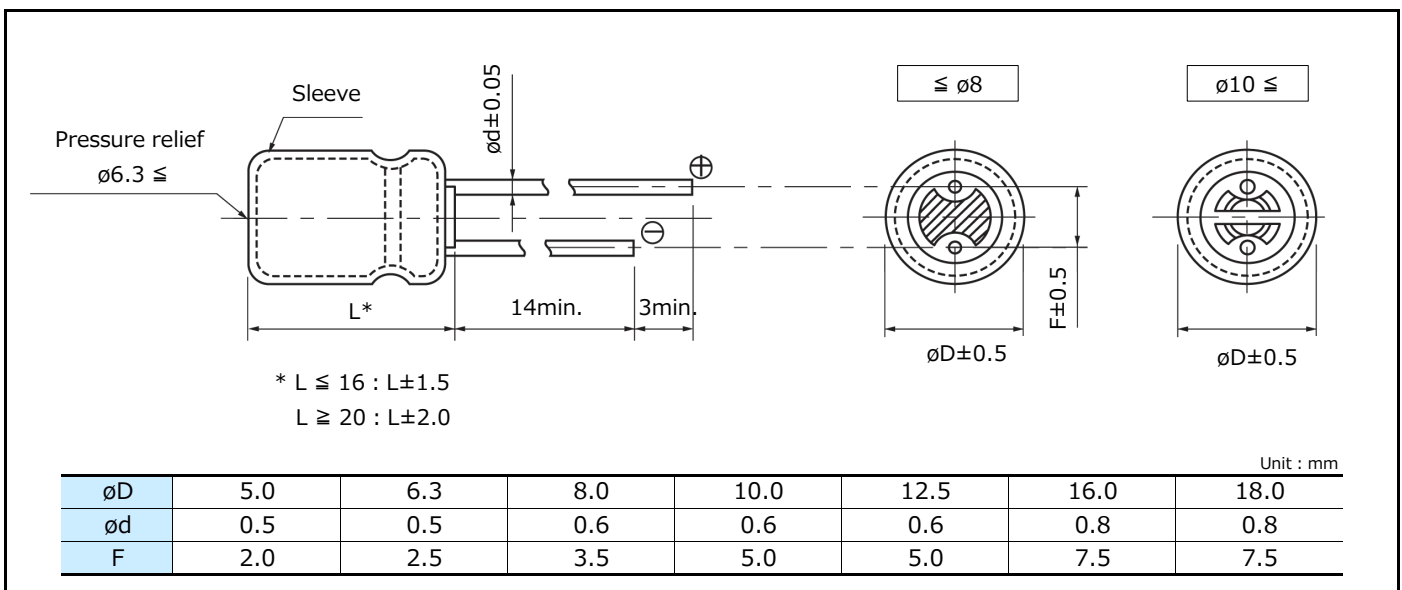

Characteristics list

Endurance : 105 °C 1000 h / $\phi 5$ to $\phi 8$, 105 °C 2000 h / $\phi 10$ to $\phi 18$

Rated voltage (V)	Capacitance ($\pm 20\%$) (μF)	Case size (mm)		Specification			Lead length (mm)				Part No.	Min. Packaging Q'ty (PCS)	
		ϕD	L	Ripple current ^{*1} (mA rms)	$\tan \delta$ ^{*2}	Endurance (h)	Lead dia. (ϕd)	Lead space				Straight leads	Taping
								Straight	Taping *B	Taping *H			
10	330	6.3	11.2	200	0.24	1000	0.5	2.5	5.0	2.5	EEUHD1A331()	200	2000
	470	8.0	11.5	250	0.24	1000	0.6	3.5	5.0	—	EEUHD1A471()	200	1000
	1000	10.0	12.5	460	0.24	2000	0.6	5.0	5.0	—	EEUHD1A102()	200	500
	2200	10.0	16.0	760	0.26	2000	0.6	5.0	5.0	—	EEUHD1A222()	200	500
	4700	12.5	20.0	1260	0.30	2000	0.6	5.0	5.0	—	EEUHD1A472()	200	500
	6800	12.5	25.0	1570	0.34	2000	0.6	5.0	5.0	—	EEUHD1A682()	200	500
	10000	16.0	25.0	1890	0.42	2000	0.8	7.5	7.5	—	EEUHD1A103()	100	250
	15000	16.0	31.5	2180	0.52	2000	0.8	7.5	—	—	EEUHD1A153	100	—
22000	18.0	35.5	2400	0.66	2000	0.8	7.5	—	—	EEUHD1A223	50	—	
16	100	5.0	11.0	110	0.20	1000	0.5	2.0	5.0	2.5	EEUHD1C101()	200	2000
	220	6.3	11.2	180	0.20	1000	0.5	2.5	5.0	2.5	EEUHD1C221()	200	2000
	330	8.0	11.5	260	0.20	1000	0.6	3.5	5.0	—	EEUHD1C331()	200	1000
	470	8.0	11.5	310	0.20	1000	0.6	3.5	5.0	—	EEUHD1C471()	200	1000
	3300	12.5	20.0	1170	0.24	2000	0.6	5.0	5.0	—	EEUHD1C332()	200	500
	4700	12.5	25.0	1480	0.26	2000	0.6	5.0	5.0	—	EEUHD1C472()	200	500
	6800	16.0	25.0	1780	0.30	2000	0.8	7.5	7.5	—	EEUHD1C682()	100	250
	8200	16.0	25.0	1780	0.34	2000	0.8	7.5	7.5	—	EEUHD1C822()	100	250
	10000	16.0	31.5	2060	0.38	2000	0.8	7.5	—	—	EEUHD1C103	100	—
	15000	18.0	35.5	2210	0.48	2000	0.8	7.5	—	—	EEUHD1C153	50	—
25	47	5.0	11.0	91	0.16	1000	0.5	2.0	5.0	2.5	EEUHD1E470()	200	2000
	68	5.0	11.0	91	0.16	1000	0.5	2.0	5.0	2.5	EEUHD1E680()	200	2000
	100	6.3	11.2	130	0.16	1000	0.5	2.5	5.0	2.5	EEUHD1E101()	200	2000
	220	8.0	11.5	230	0.16	1000	0.6	3.5	5.0	—	EEUHD1E221()	200	1000
	330	8.0	11.5	310	0.16	1000	0.6	3.5	5.0	—	EEUHD1E331()	200	1000
	470	10.0	12.5	380	0.16	2000	0.6	5.0	5.0	—	EEUHD1E471()	200	500
	1000	10.0	16.0	680	0.16	2000	0.6	5.0	5.0	—	EEUHD1E102()	200	500
	2200	12.5	20.0	1090	0.18	2000	0.6	5.0	5.0	—	EEUHD1E222()	200	500
	3300	12.5	25.0	1400	0.20	2000	0.6	5.0	5.0	—	EEUHD1E332()	200	500
	4700	16.0	25.0	1750	0.22	2000	0.8	7.5	7.5	—	EEUHD1E472()	100	250
	5600	16.0	25.0	1750	0.24	2000	0.8	7.5	7.5	—	EEUHD1E562()	100	250
	6800	16.0	31.5	2040	0.26	2000	0.8	7.5	—	—	EEUHD1E682	100	—
10000	18.0	35.5	2200	0.34	2000	0.8	7.5	—	—	EEUHD1E103	50	—	
35	47	5.0	11.0	90	0.14	1000	0.5	2.0	5.0	2.5	EEUHD1V470()	200	2000
	100	6.3	11.2	150	0.14	1000	0.5	2.5	5.0	2.5	EEUHD1V101()	200	2000
	220	8.0	11.5	270	0.14	1000	0.6	3.5	5.0	—	EEUHD1V221()	200	1000
	330	10.0	12.5	350	0.14	2000	0.6	5.0	5.0	—	EEUHD1V331()	200	500
	470	10.0	16.0	460	0.14	2000	0.6	5.0	5.0	—	EEUHD1V471()	200	500
	680	10.0	16.0	460	0.14	2000	0.6	5.0	5.0	—	EEUHD1V681()	200	500
	2200	12.5	25.0	1260	0.16	2000	0.6	5.0	5.0	—	EEUHD1V222()	200	500
	3300	16.0	25.0	1610	0.18	2000	0.8	7.5	7.5	—	EEUHD1V332()	100	250
	4700	16.0	31.5	1910	0.20	2000	0.8	7.5	—	—	EEUHD1V472	100	—
	6800	18.0	35.5	2050	0.24	2000	0.8	7.5	—	—	EEUHD1V682	50	—

*1: Ripple current (120 Hz / +105 °C)

*2: $\tan \delta$ (120 Hz / +20 °C)

• When requesting taped product, please put the letter "B" or "H" between the "()".

Lead wire pitch *B=5 mm, 7.5 mm, H=2.5 mm.

• Please refer to the page of "Taping dimensions".

Characteristics list

Endurance : 105 °C 1000 h / $\phi 5$ to $\phi 8$, 105 °C 2000 h / $\phi 10$ to $\phi 18$

Rated voltage (V)	Capacitance ($\pm 20\%$) (μF)	Case size (mm)		Specification			Lead length (mm)			Part No.	Min. Packaging Q'ty (PCS)		
		ϕD	L	Ripple current* ¹ (mA rms)	$\tan \delta$ * ²	Endurance (h)	Lead dia. (ϕd)	Lead space			Straight leads	Taping	
								Straight	Taping *B				Taping *H
50	2.2	5.0	11.0	18	0.12	1000	0.5	2.0	5.0	2.5	EEUHD1H2R2()	200	2000
	3.3	5.0	11.0	22	0.12	1000	0.5	2.0	5.0	2.5	EEUHD1H3R3()	200	2000
	4.7	5.0	11.0	26	0.12	1000	0.5	2.0	5.0	2.5	EEUHD1H4R7()	200	2000
	10	5.0	11.0	39	0.12	1000	0.5	2.0	5.0	2.5	EEUHD1H100()	200	2000
	22	5.0	11.0	65	0.12	1000	0.5	2.0	5.0	2.5	EEUHD1H220()	200	2000
	33	5.0	11.0	90	0.12	1000	0.5	2.0	5.0	2.5	EEUHD1H330()	200	2000
	47	6.3	11.2	110	0.12	1000	0.5	2.5	5.0	2.5	EEUHD1H470()	200	2000
	68	6.3	11.2	110	0.12	1000	0.5	2.5	5.0	2.5	EEUHD1H680()	200	2000
	100	8.0	11.5	180	0.12	1000	0.6	3.5	5.0	—	EEUHD1H101()	200	1000
	220	10.0	12.5	300	0.12	2000	0.6	5.0	5.0	—	EEUHD1H221()	200	500
	330	10.0	16.0	410	0.12	2000	0.6	5.0	5.0	—	EEUHD1H331()	200	500
	470	10.0	20.0	530	0.12	2000	0.6	5.0	5.0	—	EEUHD1H471()	200	500
	560	16.0	15.0	650	0.12	2000	0.8	7.5	7.5	—	EEUHD1H561S()	100	250
	680	16.0	15.0	650	0.12	2000	0.8	7.5	7.5	—	EEUHD1H681S()	100	250
	1000	12.5	25.0	950	0.12	2000	0.6	5.0	5.0	—	EEUHD1H102()	200	500
2200	16.0	31.5	1470	0.14	2000	0.8	7.5	—	—	EEUHD1H222	100	—	
3300	18.0	35.5	1770	0.16	2000	0.8	7.5	—	—	EEUHD1H332	50	—	

*1: Ripple current (120 Hz / +105 °C)

*2: $\tan \delta$ (120 Hz / +20 °C)

- When requesting taped product, please put the letter "B" or "H" between the "()".
Lead wire pitch *B=5 mm, 7.5 mm, H=2.5 mm.
- Please refer to the page of "Taping dimensions".



This Series is no longer available for purchase in the country of Japan.



Radial Lead Type NHG-A series

Features

- Endurance : 105 °C 1000 h to 2000 h
- AEC-Q200 compliant (6.3 V to 100 V)
- RoHS compliant

Specifications

Category temp. range	-55 °C to +105 °C	-25 °C to +105 °C
Rated voltage range	6.3 V to 100 V	160 V to 450 V
Capacitance range	2.2 μF to 22000 μF	2.2 μF to 330 μF
Capacitance tolerance	±20 % (120 Hz / +20°C)	
Leakage current	$I \leq 0.01 CV$ or 3 (μA) After 2 minutes (Which is greater)	$I \leq 0.06 CV + 10$ (μA) After 2 minutes
Dissipation factor (tan δ)	Please see the attached characteristics list	
Endurance	After following life test with DC voltage and +105 °C±2 °C ripple current value applied (The sum of DC and ripple peak voltage shall not exceed the rated working voltage) for 2000 h, when the capacitors are restored to 20 °C, the capacitors shall meet the limits specified bellow. Duration 6.3 V to 100 V (ø5 to ø8) : 1000 h, (ø10 to ø18) : 2000 h 160 V to 450 V : 2000 h	
	Capacitance change	Within ±20 % of the initial value
	Dissipation factor (tan δ)	≤ 200 % of the initial limit
	DC leakage current	Within the initial limit
Shelf life	After storage for 1000 h at +105 °C±2 °C with no voltage applied and then being stabilized at +20 °C, capacitors shall meet the limits specified in endurance. (With voltage treatment)	

Frequency correction factor for ripple current

Rated voltage (V)	Capacitance (μF)	Frequency (Hz)				
		60	120	1 k	10 k	100 k
6.3 to 100	2.2 to 33	0.75	1.00	1.55	1.80	2.00
	47 to 470	0.80	1.00	1.35	1.50	1.50
	1000 to 22000	0.85	1.00	1.10	1.15	1.15
160 to 450	2.2 to 330	0.80	1.00	1.35	1.50	1.50

Dimensions

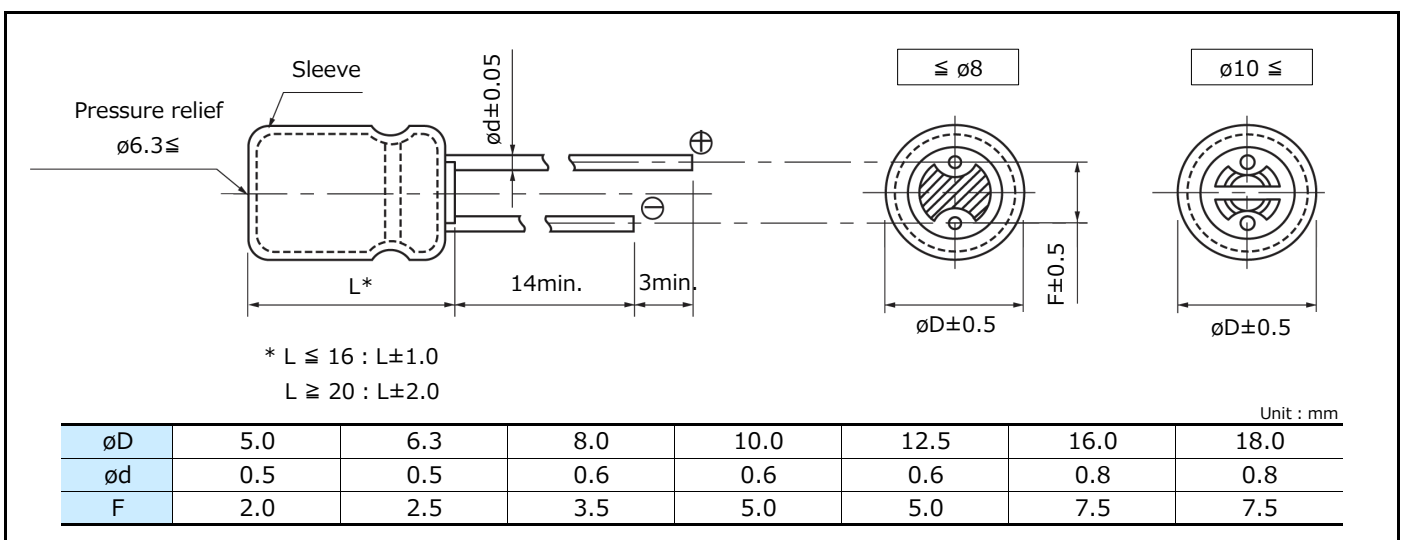

Characteristics list

Endurance : 105 °C 1000 h to 2000 h

Rated voltage (V)	Capacitance (±20 %) (μF)	Case size (mm)		Specification			Lead length (mm)				Part No.	Min. Packaging Q'ty (PCS)	
		øD	L	Ripple current*1 (mA rms)	tan δ*2	Endurance (h)	Lead dia. (ød)	Lead space				Straight leads	Taping
								Straight	Taping *B	Taping *i			
6.3	100	5.0	11.0	91	0.28	1000	0.5	2.0	5.0	2.5	ECA0JHG101()	200	2000
	220	5.0	11.0	140	0.28	1000	0.5	2.0	5.0	2.5	ECA0JHG221()	200	2000
	470	6.3	11.2	230	0.28	1000	0.5	2.5	5.0	2.5	ECA0JHG471()	200	2000
	1000	8.0	11.5	380	0.28	1000	0.6	3.5	5.0	—	ECA0JHG102()	200	1000
	2200	10.0	16.0	710	0.30	2000	0.6	5.0	5.0	—	ECA0JHG222()	200	500
	3300	10.0	20.0	840	0.32	2000	0.6	5.0	5.0	—	ECA0JHG332()	200	500
	4700	12.5	20.0	1090	0.34	2000	0.6	5.0	5.0	—	ECA0JHG472()	200	500
	6800	12.5	25.0	1350	0.38	2000	0.6	5.0	5.0	—	ECA0JHG682()	200	500
	10000	16.0	25.0	1650	0.46	2000	0.8	7.5	7.5	—	ECA0JHG103()	100	250
	15000	16.0	31.5	2010	0.56	2000	0.8	7.5	—	—	ECA0JHG153	100	—
10	22000	18.0	35.5	2350	0.70	2000	0.8	7.5	—	—	ECA0JHG223	50	—
	330	6.3	11.2	200	0.24	1000	0.5	2.5	5.0	2.5	ECA1AHG331()	200	2000
	470	8.0	11.5	250	0.24	1000	0.6	3.5	5.0	—	ECA1AHG471()	200	1000
	1000	10.0	12.5	460	0.24	2000	0.6	5.0	5.0	—	ECA1AHG102()	200	500
	2200	10.0	20.0	760	0.26	2000	0.6	5.0	5.0	—	ECA1AHG222()	200	500
	3300	12.5	20.0	1000	0.28	2000	0.6	5.0	5.0	—	ECA1AHG332()	200	500
	4700	12.5	25.0	1260	0.30	2000	0.6	5.0	5.0	—	ECA1AHG472()	200	500
	6800	16.0	25.0	1570	0.34	2000	0.8	7.5	7.5	—	ECA1AHG682()	100	250
	10000	16.0	31.5	1890	0.42	2000	0.8	7.5	—	—	ECA1AHG103	100	—
	15000	18.0	35.5	2180	0.52	2000	0.8	7.5	—	—	ECA1AHG153	50	—
16	100	5.0	11.0	110	0.20	1000	0.5	2.0	5.0	2.5	ECA1CHG101()	200	2000
	220	6.3	11.2	180	0.20	1000	0.5	2.5	5.0	2.5	ECA1CHG221()	200	2000
	330	8.0	11.5	260	0.20	1000	0.6	3.5	5.0	—	ECA1CHG331()	200	1000
	470	8.0	11.5	310	0.20	1000	0.6	3.5	5.0	—	ECA1CHG471()	200	1000
	1000	10.0	16.0	560	0.20	2000	0.6	5.0	5.0	—	ECA1CHG102()	200	500
	2200	12.5	20.0	920	0.22	2000	0.6	5.0	5.0	—	ECA1CHG222()	200	500
	3300	12.5	25.0	1170	0.24	2000	0.6	5.0	5.0	—	ECA1CHG332()	200	500
	4700	16.0	25.0	1480	0.26	2000	0.8	7.5	7.5	—	ECA1CHG472()	100	250
	6800	16.0	31.5	1780	0.30	2000	0.8	7.5	—	—	ECA1CHG682	100	—
	10000	18.0	35.5	2060	0.38	2000	0.8	7.5	—	—	ECA1CHG103	50	—
25	47	5.0	11.0	91	0.16	1000	0.5	2.0	5.0	2.5	ECA1EHG470()	200	2000
	100	6.3	11.2	130	0.16	1000	0.5	2.5	5.0	2.5	ECA1EHG101()	200	2000
	220	8.0	11.5	230	0.16	1000	0.6	3.5	5.0	—	ECA1EHG221()	200	1000
	330	8.0	11.5	310	0.16	1000	0.6	3.5	5.0	—	ECA1EHG331()	200	1000
	470	10.0	12.5	380	0.16	2000	0.6	5.0	5.0	—	ECA1EHG471()	200	500
	1000	10.0	20.0	680	0.16	2000	0.6	5.0	5.0	—	ECA1EHG102()	200	500
	2200	12.5	25.0	1090	0.18	2000	0.6	5.0	5.0	—	ECA1EHG222()	200	500
	3300	16.0	25.0	1400	0.20	2000	0.8	7.5	7.5	—	ECA1EHG332()	100	250
	4700	16.0	31.5	1750	0.22	2000	0.8	7.5	—	—	ECA1EHG472	100	—
	6800	18.0	35.5	2040	0.26	2000	0.8	7.5	—	—	ECA1EHG682	50	—
35	47	5.0	11.0	90	0.14	1000	0.5	2.0	5.0	2.5	ECA1VHG470()	200	2000
	100	6.3	11.2	150	0.14	1000	0.5	2.5	5.0	2.5	ECA1VHG101()	200	2000
	220	8.0	11.5	270	0.14	1000	0.6	3.5	5.0	—	ECA1VHG221()	200	1000
	330	10.0	12.5	350	0.14	2000	0.6	5.0	5.0	—	ECA1VHG331()	200	500
	470	10.0	16.0	460	0.14	2000	0.6	5.0	5.0	—	ECA1VHG471()	200	500
	1000	12.5	20.0	810	0.14	2000	0.6	5.0	5.0	—	ECA1VHG102()	200	500
	2200	16.0	25.0	1260	0.16	2000	0.8	7.5	7.5	—	ECA1VHG222()	100	250
	3300	16.0	31.5	1610	0.18	2000	0.8	7.5	—	—	ECA1VHG332	100	—
	4700	18.0	35.5	1910	0.20	2000	0.8	7.5	—	—	ECA1VHG472	50	—

*1: Ripple current (120 Hz / +105 °C)

*2: tan δ (120 Hz / +20 °C)

• When requesting taped product, please put the letter "B" or "i" between the "()".

Lead wire pitch *B=5 mm, 7.5 mm, i=2.5 mm.

• Please refer to the page of "Taping dimensions".

Characteristics list

Endurance : 105 °C 1000 h to 2000 h

Rated voltage (V)	Capacitance (±20 %) (μF)	Case size (mm)		Specification			Lead length (mm)			Part No.	Min. Packaging Q'ty (PCS)		
		øD	L	Ripple current* ¹ (mA rms)	tan δ* ²	Endurance (h)	Lead dia. (ød)	Lead space			Straight leads	Taping	
								Straight	Taping *B				Taping *i
50	2.2	5.0	11.0	18	0.12	1000	0.5	2.0	5.0	2.5	ECA1HHG2R2()	200	2000
	3.3	5.0	11.0	22	0.12	1000	0.5	2.0	5.0	2.5	ECA1HHG3R3()	200	2000
	4.7	5.0	11.0	26	0.12	1000	0.5	2.0	5.0	2.5	ECA1HHG4R7()	200	2000
	10	5.0	11.0	39	0.12	1000	0.5	2.0	5.0	2.5	ECA1HHG100()	200	2000
	22	5.0	11.0	65	0.12	1000	0.5	2.0	5.0	2.5	ECA1HHG220()	200	2000
	33	5.0	11.0	90	0.12	1000	0.5	2.0	5.0	2.5	ECA1HHG330()	200	2000
	47	6.3	11.2	110	0.12	1000	0.5	2.5	5.0	2.5	ECA1HHG470()	200	2000
	100	8.0	11.5	180	0.12	1000	0.6	3.5	5.0	—	ECA1HHG101()	200	1000
	220	10.0	12.5	300	0.12	2000	0.6	5.0	5.0	—	ECA1HHG221()	200	500
	330	10.0	16.0	410	0.12	2000	0.6	5.0	5.0	—	ECA1HHG331()	200	500
	470	10.0	20.0	530	0.12	2000	0.6	5.0	5.0	—	ECA1HHG471()	200	500
	1000	12.5	25.0	950	0.12	2000	0.6	5.0	5.0	—	ECA1HHG102()	200	500
	2200	16.0	31.5	1470	0.14	2000	0.8	7.5	—	—	ECA1HHG222	100	—
3300	18.0	35.5	1770	0.16	2000	0.8	7.5	—	—	ECA1HHG332	50	—	
63	10	5.0	11.0	46	0.10	1000	0.5	2.0	5.0	2.5	ECA1JHG100()	200	2000
	22	5.0	11.0	71	0.10	1000	0.5	2.0	5.0	2.5	ECA1JHG220()	200	2000
	33	6.3	11.2	100	0.10	1000	0.5	2.5	5.0	2.5	ECA1JHG330()	200	2000
	47	6.3	11.2	120	0.10	1000	0.5	2.5	5.0	2.5	ECA1JHG470()	200	2000
	100	10.0	12.5	215	0.10	2000	0.6	5.0	5.0	—	ECA1JHG101()	200	500
	220	10.0	16.0	335	0.10	2000	0.6	5.0	5.0	—	ECA1JHG221()	200	500
	330	10.0	20.0	510	0.10	2000	0.6	5.0	5.0	—	ECA1JHG331()	200	500
	470	12.5	20.0	640	0.10	2000	0.6	5.0	5.0	—	ECA1JHG471()	200	500
	1000	16.0	25.0	930	0.10	2000	0.8	7.5	7.5	—	ECA1JHG102()	100	250
	2200	18.0	35.5	1610	0.12	2000	0.8	7.5	—	—	ECA1JHG222	50	—
100	2.2	5.0	11.0	21	0.08	1000	0.5	2.0	5.0	2.5	ECA2AHG2R2()	200	2000
	3.3	5.0	11.0	31	0.08	1000	0.5	2.0	5.0	2.5	ECA2AHG3R3()	200	2000
	4.7	5.0	11.0	38	0.08	1000	0.5	2.0	5.0	2.5	ECA2AHG4R7()	200	2000
	10	6.3	11.2	54	0.08	1000	0.5	2.5	5.0	2.5	ECA2AHG100()	200	2000
	22	6.3	11.2	93	0.08	1000	0.5	2.5	5.0	2.5	ECA2AHG220()	200	2000
	33	8.0	11.5	130	0.08	1000	0.6	3.5	5.0	—	ECA2AHG330()	200	1000
	47	10.0	12.5	165	0.08	2000	0.6	5.0	5.0	—	ECA2AHG470()	200	500
	100	10.0	20.0	265	0.08	2000	0.6	5.0	5.0	—	ECA2AHG101()	200	500
	220	12.5	25.0	440	0.08	2000	0.6	5.0	5.0	—	ECA2AHG221()	200	500
	330	16.0	25.0	540	0.08	2000	0.8	7.5	7.5	—	ECA2AHG331()	100	250
	470	16.0	25.0	715	0.08	2000	0.8	7.5	7.5	—	ECA2AHG471()	100	250
	1000	18.0	35.5	985	0.08	2000	0.8	7.5	—	—	ECA2AHG102	50	—

*1: Ripple current (120 Hz / +105 °C)

*2: tan δ (120 Hz / +20 °C)

- When requesting taped product, please put the letter "B" or "i" between the "()".
Lead wire pitch *B=5 mm, 7.5 mm, i=2.5 mm.
- Please refer to the page of "Taping dimensions".

Characteristics list

Endurance : 105 °C 2000 h

Rated voltage (V)	Capacitance (±20 %) (μF)	Case size (mm)		Specification			Lead length (mm)			Part No.	Min. Packaging Q'ty (PCS)		
		øD	L	Ripple current*1 (mA rms)	tan δ*2	Endurance (h)	Lead dia. (ød)	Lead space			Straight leads	Taping	
								Straight	Taping *B				Taping *i
160	2.2	6.3	11.2	25	0.15	2000	0.5	2.5	5.0	2.5	ECA2CHG2R2()	200	2000
	3.3	6.3	11.2	36	0.15	2000	0.5	2.5	5.0	2.5	ECA2CHG3R3()	200	2000
	4.7	6.3	11.2	43	0.15	2000	0.5	2.5	5.0	2.5	ECA2CHG4R7()	200	2000
	10	10.0	12.5	70	0.15	2000	0.6	5.0	5.0	—	ECA2CHG100()	200	500
	22	10.0	20.0	130	0.15	2000	0.6	5.0	5.0	—	ECA2CHG220()	200	500
	33	10.0	20.0	180	0.15	2000	0.6	5.0	5.0	—	ECA2CHG330()	200	500
	47	12.5	20.0	220	0.15	2000	0.6	5.0	5.0	—	ECA2CHG470()	200	500
	100	16.0	25.0	335	0.15	2000	0.8	7.5	7.5	—	ECA2CHG101()	100	250
	220	16.0	31.5	540	0.15	2000	0.8	7.5	—	—	ECA2CHG221	100	—
	330	18.0	31.5	705	0.15	2000	0.8	7.5	—	—	ECA2CHG331	50	—
200	2.2	6.3	11.2	25	0.15	2000	0.5	2.5	5.0	2.5	ECA2DHG2R2()	200	2000
	3.3	6.3	11.2	36	0.15	2000	0.5	2.5	5.0	2.5	ECA2DHG3R3()	200	2000
	4.7	8.0	11.5	50	0.15	2000	0.6	3.5	5.0	—	ECA2DHG4R7()	200	1000
	10	10.0	16.0	80	0.15	2000	0.6	5.0	5.0	—	ECA2DHG100()	200	500
	22	10.0	20.0	140	0.15	2000	0.6	5.0	5.0	—	ECA2DHG220()	200	500
	33	12.5	20.0	190	0.15	2000	0.6	5.0	5.0	—	ECA2DHG330()	200	500
	47	12.5	20.0	220	0.15	2000	0.6	5.0	5.0	—	ECA2DHG470()	200	500
	100	16.0	25.0	335	0.15	2000	0.8	7.5	7.5	—	ECA2DHG101()	100	250
	220	18.0	31.5	575	0.15	2000	0.8	7.5	—	—	ECA2DHG221	50	—
250	2.2	6.3	11.2	29	0.15	2000	0.5	2.5	5.0	2.5	ECA2EHG2R2()	200	2000
	3.3	8.0	11.5	42	0.15	2000	0.6	3.5	5.0	—	ECA2EHG3R3	200	1000
	4.7	8.0	11.5	50	0.15	2000	0.6	3.5	5.0	—	ECA2EHG4R7()	200	1000
	10	10.0	16.0	88	0.15	2000	0.6	5.0	5.0	—	ECA2EHG100()	200	500
	22	12.5	20.0	155	0.15	2000	0.6	5.0	5.0	—	ECA2EHG220()	200	500
	33	12.5	20.0	190	0.15	2000	0.6	5.0	5.0	—	ECA2EHG330()	200	500
	47	12.5	25.0	230	0.15	2000	0.6	5.0	5.0	—	ECA2EHG470()	200	500
	100	16.0	31.5	365	0.15	2000	0.8	7.5	—	—	ECA2EHG101	100	—
350	2.2	8.0	11.5	31	0.20	2000	0.6	3.5	5.0	—	ECA2VHG2R2()	200	1000
	3.3	10.0	12.5	38	0.20	2000	0.6	5.0	5.0	—	ECA2VHG3R3()	200	500
	4.7	10.0	16.0	50	0.20	2000	0.6	5.0	5.0	—	ECA2VHG4R7()	200	500
	10	10.0	20.0	82	0.20	2000	0.6	5.0	5.0	—	ECA2VHG100()	200	500
	22	12.5	20.0	130	0.20	2000	0.6	5.0	5.0	—	ECA2VHG220()	200	500
	33	16.0	25.0	195	0.20	2000	0.8	7.5	7.5	—	ECA2VHG330()	100	250
	47	16.0	25.0	230	0.20	2000	0.8	7.5	7.5	—	ECA2VHG470()	100	250
	100	18.0	31.5	375	0.20	2000	0.8	7.5	—	—	ECA2VHG101	50	—

*1: Ripple current (120 Hz / +105 °C)

*2: tan δ (120 Hz / +20 °C)

• When requesting taped product, please put the letter "B" or "i" between the "()".

Lead wire pitch *B=5 mm, 7.5 mm, i=2.5 mm.

• Please refer to the page of "Taping dimensions".

Characteristics list

Endurance : 105 °C 2000 h

Rated voltage (V)	Capacitance (±20 %) (μF)	Case size (mm)		Specification			Lead length (mm)			Part No.	Min. Packaging Q'ty (PCS)		
		øD	L	Ripple current* ¹ (mA rms)	tan δ* ²	Endurance (h)	Lead dia. (ød)	Lead space			Straight leads	Taping	
								Straight	Taping *B				Taping *i
400	2.2	8.0	11.5	30	0.24	2000	0.6	3.5	5.0	—	ECA2GHG2R2()	200	1000
	3.3	10.0	12.5	40	0.24	2000	0.6	5.0	5.0	—	ECA2GHG3R3()	200	500
	4.7	10.0	16.0	50	0.24	2000	0.6	5.0	5.0	—	ECA2GHG4R7()	200	500
	10	10.0	20.0	80	0.24	2000	0.6	5.0	5.0	—	ECA2GHG100()	200	500
	22	12.5	25.0	145	0.24	2000	0.6	5.0	5.0	—	ECA2GHG220()	200	500
	33	16.0	25.0	195	0.24	2000	0.8	7.5	7.5	—	ECA2GHG330()	100	250
	47	16.0	31.5	250	0.24	2000	0.8	7.5	—	—	ECA2GHG470	100	—
450	2.2	10.0	12.5	29	0.24	2000	0.6	5.0	5.0	—	ECA2WHG2R2()	200	500
	3.3	10.0	16.0	41	0.24	2000	0.6	5.0	5.0	—	ECA2WHG3R3()	200	500
	4.7	10.0	20.0	49	0.24	2000	0.6	5.0	5.0	—	ECA2WHG4R7()	200	500
	10	12.5	20.0	75	0.24	2000	0.6	5.0	5.0	—	ECA2WHG100()	200	500
	22	16.0	25.0	115	0.24	2000	0.8	7.5	7.5	—	ECA2WHG220()	100	250
	33	16.0	31.5	155	0.24	2000	0.8	7.5	—	—	ECA2WHG330	100	—

*1: Ripple current (120 Hz / +105 °C)

*2: tan δ (120 Hz / +20 °C)

- When requesting taped product, please put the letter "B" or "i" between the "()".
Lead wire pitch *B=5 mm, 7.5 mm, i=2.5 mm.
- Please refer to the page of "Taping dimensions".



This Series is no longer available for purchase in the country of Japan.

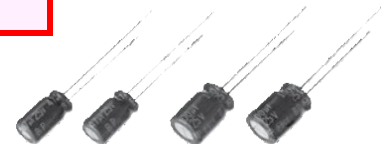

Radial Lead Type GA-A (Bi-polar) series

Features

- Endurance : 105 °C 1000 h to 2000 h
- RoHS compliant

Specifications

Category temp. range	-40 °C to +105 °C	
Rated voltage range	6.3 V to 50 V	
Capacitance range	2.2 μF to 330 μF	
Capacitance tolerance	±20 % (120 Hz / +20°C)	
Leakage current	I ≤ 0.03 CV + 3 (μA) After 2 minutes or I ≤ 0.03 CV or 3 (μA) After 5 minutes (Whichever is greater)	
Dissipation factor (tan δ)	Please see the attached characteristics list	
Endurance	After following life test of DC working voltage at +105 °C±2 °C when the capacitors are restored to 20 °C, the capacitors shall meet the following limits. Duration ø5 to ø8 : 1000 h (500 h for each polarity) ø10 : 2000 h (1000 h for each polarity)	
	Capacitance change	Within ±20 % of the initial value
	Dissipation factor (tan δ)	≤ 200 % of the initial limit
	DC leakage current	Within the initial limit
Shelf life	After storage for 1000 h at +105 °C±2 °C with no voltage applied and then being stabilized at +20 °C, capacitors shall meet the limits specified in endurance. (With voltage treatment)	

Frequency correction factor for ripple current

Freq.(Hz)	50, 60	120	1 k	10 k to
Capacitance (μF)				
2.2 to 330	0.70	1.00	1.30	1.70

Dimensions

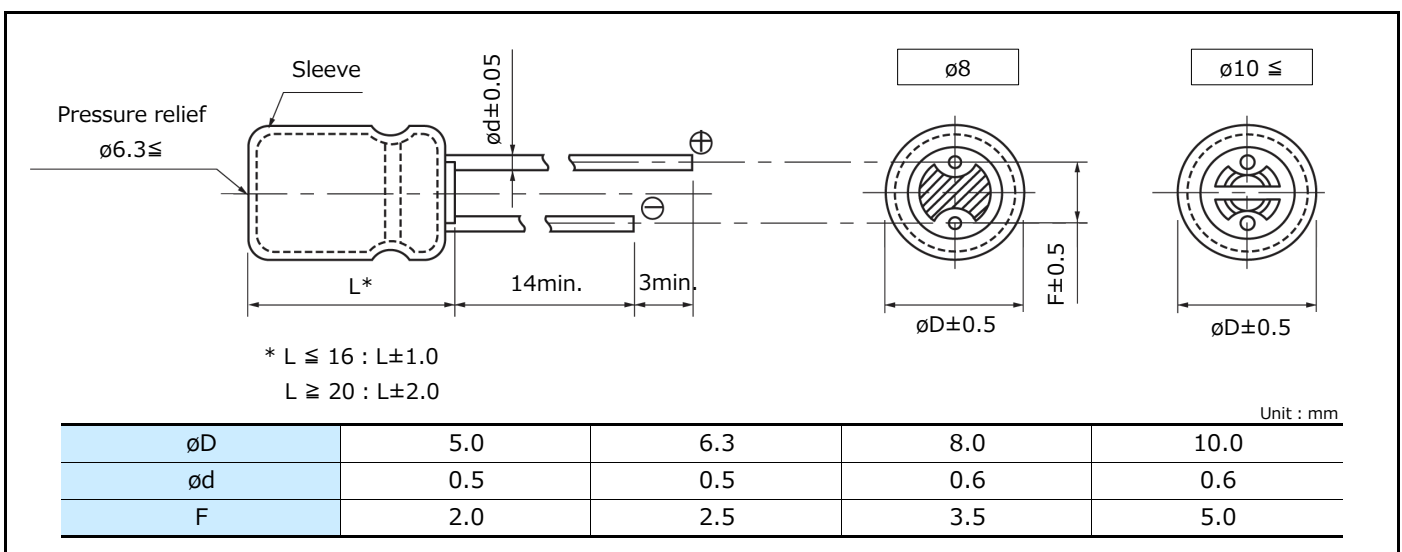

Characteristics list

Endurance : 105 °C 1000 h / $\phi 5$ to $\phi 8$ (500 h for each polarity), 105 °C 2000 h / $\phi 10$ (1000 h for each polarity)

Rated voltage (V)	Capacitance ($\pm 20\%$) (μF)	Case size (mm)		Specification		Lead length (mm)				Part No.	Min. Packaging Q'ty (PCS)	
		ϕD	L	Ripple current* ¹ (mA rms)	$\tan \delta$ * ²	Lead dia. (ϕd)	Lead space				Straight leads	Taping
							Straight	Taping *B	Taping *i			
6.3	100	6.3	11.2	130	0.30	0.5	2.5	5.0	2.5	ECA0JEN101()	200	2000
	330	8.0	11.5	250	0.30	0.6	3.5	5.0	—	ECA0JEN331()	200	1000
10	47	5.0	11.0	90	0.24	0.5	2.0	5.0	2.5	ECA1AEN470()	200	2000
16	10	5.0	11.0	40	0.20	0.5	2.0	5.0	2.5	ECA1CEN100()	200	2000
	22	5.0	11.0	60	0.20	0.5	2.0	5.0	2.5	ECA1CEN220()	200	2000
	33	5.0	11.0	80	0.20	0.5	2.0	5.0	2.5	ECA1CEN330()	200	2000
	47	6.3	11.2	100	0.20	0.5	2.5	5.0	2.5	ECA1CEN470()	200	2000
25	10	5.0	11.0	45	0.15	0.5	2.0	5.0	2.5	ECA1EEN100()	200	2000
	22	6.3	11.2	60	0.15	0.5	2.5	5.0	2.5	ECA1EEN220()	200	2000
	33	6.3	11.2	90	0.15	0.5	2.5	5.0	2.5	ECA1EEN330()	200	2000
	47	6.3	11.2	110	0.15	0.5	2.5	5.0	2.5	ECA1EEN470()	200	2000
35	100	8.0	11.5	180	0.15	0.6	3.5	5.0	—	ECA1EEN101()	200	1000
	33	8.0	11.5	100	0.15	0.6	3.5	5.0	—	ECA1VEN330()	200	1000
	100	10.0	16.0	230	0.15	0.6	5.0	5.0	—	ECA1VEN101()	200	500
50	2.2	5.0	11.0	18	0.15	0.5	2.0	5.0	2.5	ECA1HEN2R2()	200	2000
	3.3	5.0	11.0	25	0.15	0.5	2.0	5.0	2.5	ECA1HEN3R3()	200	2000
	4.7	5.0	11.0	30	0.15	0.5	2.0	5.0	2.5	ECA1HEN4R7()	200	2000
	10	6.3	11.2	50	0.15	0.5	2.5	5.0	2.5	ECA1HEN100()	200	2000
	22	8.0	11.5	90	0.15	0.6	3.5	5.0	—	ECA1HEN220()	200	1000
	33	8.0	11.5	110	0.15	0.6	3.5	5.0	—	ECA1HEN330()	200	1000
	47	10.0	12.5	140	0.15	0.6	5.0	5.0	—	ECA1HEN470()	200	500
100	10.0	20.0	250	0.15	0.6	5.0	5.0	—	ECA1HEN101()	200	500	

*1: Ripple current (120 Hz / +105 °C)

*2: $\tan \delta$ (120 Hz / +20 °C)

- When requesting taped product, please put the letter "B" or "i" between the "()".
Lead wire pitch *B=5 mm, i=2.5mm.
- Please refer to the page of "Taping dimensions".



This Series is no longer available for purchase in the country of Japan.



Radial Lead Type

M-A series

Features

- Endurance : 85 °C 2000 h
- Smaller than series SU
- RoHS compliant

Specifications

Category temp. range	-40 °C to +85 °C	-25 °C to +85 °C
Rated voltage range	6.3 V to 100 V	160 V to 450 V
Capacitance range	2.2 μF to 22000 μF	2.2 μF to 470 μF
Capacitance tolerance	±20 % (120 Hz / +20°C)	
Leakage current	$I \leq 0.01 CV$ or 3 (μA) After 2 minutes (Which is greater)	$I \leq 0.06 CV + 10$ (μA) After 2 minutes
Dissipation factor (tan δ)	Please see the attached characteristics list	
Endurance	After applying rated working voltage for 2000 hours at +85 °C±2 °C, when the capacitors are restored to 20°C, capacitors shall meet the following limits.	
	Capacitance change	Within ±20 % of the initial value
	Dissipation factor (tan δ)	≤ 150 % of the initial limit
	DC leakage current	Within the initial limit
Shelf life	After storage for 1000 h at +85 °C±2 °C with no voltage applied and then being stabilized at +20 °C, capacitors shall meet the limits specified in endurance. (With voltage treatment)	

Frequency correction factor for ripple current

Freq. (Hz)	50, 60	120	1 k	10 k to
Cap. (μF)				
2.2 to 22000	0.70	1.00	1.30	1.70

Dimensions

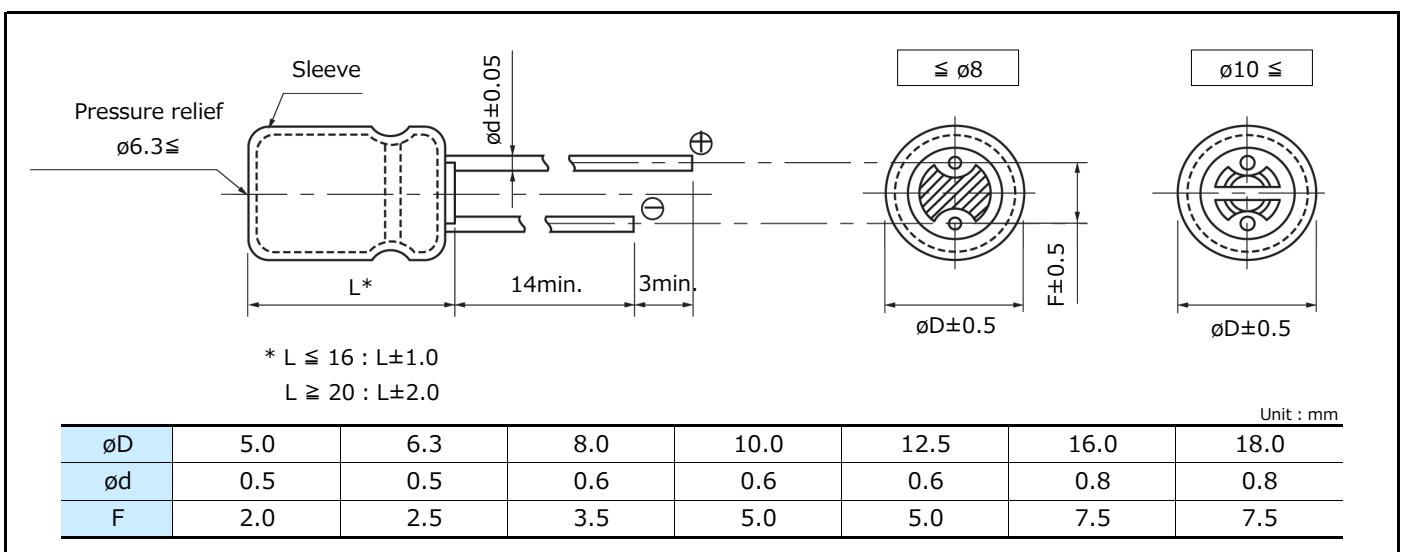

Characteristics list

Endurance : 85 °C 2000 h

Rated voltage (V)	Capacitance (±20 %) (μF)	Case size (mm)		Specification		Lead length (mm)				Part No.	Min. Packaging Q'ty (PCS)	
		øD	L	Ripple current*1 (mA rms)	tan δ*2	Lead dia. (ød)	Lead space				Straight leads	Taping
							Straight	Taping *B	Taping *i			
6.3	220	5.0	11.0	240	0.28	0.5	2.0	5.0	2.5	ECA0JM221()	200	2000
	470	6.3	11.2	380	0.28	0.5	2.5	5.0	2.5	ECA0JM471()	200	2000
	1000	8.0	11.5	580	0.28	0.6	3.5	5.0	—	ECA0JM102()	200	1000
	2200	10.0	16.0	890	0.30	0.6	5.0	5.0	—	ECA0JM222()	200	500
	3300	10.0	20.0	1020	0.32	0.6	5.0	5.0	—	ECA0JM332()	200	500
	4700	12.5	20.0	1170	0.34	0.6	5.0	5.0	—	ECA0JM472()	200	500
	6800	12.5	25.0	1270	0.38	0.6	5.0	5.0	—	ECA0JM682()	200	500
	10000	16.0	25.0	1450	0.46	0.8	7.5	7.5	—	ECA0JM103()	100	250
	15000	16.0	31.5	1700	0.56	0.8	7.5	—	—	ECA0JM153	100	—
22000	18.0	35.5	1900	0.70	0.8	7.5	—	—	ECA0JM223	50	—	
10	330	6.3	11.2	330	0.24	0.5	2.5	5.0	2.5	ECA1AM331()	200	2000
	1000	10.0	12.5	630	0.24	0.6	5.0	5.0	—	ECA1AM102()	200	500
	2200	10.0	20.0	920	0.26	0.6	5.0	5.0	—	ECA1AM222()	200	500
	3300	12.5	20.0	1090	0.28	0.6	5.0	5.0	—	ECA1AM332()	200	500
	4700	12.5	25.0	1200	0.30	0.6	5.0	5.0	—	ECA1AM472()	200	500
	6800	16.0	25.0	1400	0.34	0.8	7.5	7.5	—	ECA1AM682()	100	250
	10000	16.0	31.5	1600	0.42	0.8	7.5	—	—	ECA1AM103	100	—
	15000	18.0	35.5	1850	0.52	0.8	7.5	—	—	ECA1AM153	50	—
16	10	5.0	11.0	30	0.20	0.5	2.0	5.0	2.5	ECA1CM100()	200	2000
	22	5.0	11.0	75	0.20	0.5	2.0	5.0	2.5	ECA1CM220()	200	2000
	33	5.0	11.0	110	0.20	0.5	2.0	5.0	2.5	ECA1CM330()	200	2000
	47	5.0	11.0	130	0.20	0.5	2.0	5.0	2.5	ECA1CM470()	200	2000
	100	5.0	11.0	180	0.20	0.5	2.0	5.0	2.5	ECA1CM101()	200	2000
	220	6.3	11.2	280	0.20	0.5	2.5	5.0	2.5	ECA1CM221()	200	2000
	470	8.0	11.5	440	0.20	0.6	3.5	5.0	—	ECA1CM471()	200	1000
	1000	10.0	16.0	680	0.20	0.6	5.0	5.0	—	ECA1CM102()	200	500
	2200	12.5	20.0	1000	0.22	0.6	5.0	5.0	—	ECA1CM222()	200	500
	3300	12.5	25.0	1200	0.24	0.6	5.0	5.0	—	ECA1CM332()	200	500
	4700	16.0	25.0	1360	0.26	0.8	7.5	7.5	—	ECA1CM472()	100	250
	6800	16.0	31.5	1600	0.30	0.8	7.5	—	—	ECA1CM682	100	—
10000	18.0	35.5	1800	0.38	0.8	7.5	—	—	ECA1CM103	50	—	
25	100	6.3	11.2	180	0.16	0.5	2.5	5.0	2.5	ECA1EM101()	200	2000
	330	8.0	11.5	390	0.16	0.6	3.5	5.0	—	ECA1EM331()	200	1000
	470	10.0	12.5	480	0.16	0.6	5.0	5.0	—	ECA1EM471()	200	500
	1000	10.0	20.0	850	0.16	0.6	5.0	5.0	—	ECA1EM102()	200	500
	2200	12.5	25.0	1200	0.18	0.6	5.0	5.0	—	ECA1EM222()	200	500
	3300	16.0	25.0	1300	0.20	0.8	7.5	7.5	—	ECA1EM332()	100	250
	4700	16.0	31.5	1500	0.22	0.8	7.5	—	—	ECA1EM472	100	—
6800	18.0	35.5	1750	0.26	0.8	7.5	—	—	ECA1EM682	50	—	

*1: Ripple current (120 Hz / +85 °C)

*2: tan δ (120 Hz / +20 °C)

- When requesting taped product, please put the letter "B" or "i" between the "()".
Lead wire pitch *B=5 mm, 7.5 mm, i=2.5 mm
- Please refer to the page of "Taping dimensions".

Characteristics list

Endurance : 85 °C 2000 h

Rated voltage (V)	Capacitance (±20 %) (μF)	Case size (mm)		Specification		Lead length (mm)			Part No.	Min. Packaging Q'ty (PCS)		
		øD	L	Ripple current*1 (mA rms)	tan δ*2	Lead dia. (ød)	Lead space			Straight leads	Taping	
							Straight	Taping *B				Taping *i
35	10	5.0	11.0	60	0.12	0.5	2.0	5.0	2.5	ECA1VM100()	200	2000
	47	5.0	11.0	130	0.14	0.5	2.0	5.0	2.5	ECA1VM470()	200	2000
	100	6.3	11.2	210	0.14	0.5	2.5	5.0	2.5	ECA1VM101()	200	2000
	220	8.0	11.5	350	0.14	0.6	3.5	5.0	—	ECA1VM221()	200	1000
	330	10.0	12.5	440	0.14	0.6	5.0	5.0	—	ECA1VM331()	200	500
	470	10.0	16.0	550	0.14	0.6	5.0	5.0	—	ECA1VM471()	200	500
	1000	12.5	20.0	900	0.14	0.6	5.0	5.0	—	ECA1VM102()	200	500
	2200	16.0	25.0	1250	0.16	0.8	7.5	7.5	—	ECA1VM222()	100	250
	3300	16.0	31.5	1400	0.18	0.8	7.5	—	—	ECA1VM332	100	—
4700	18.0	35.5	1600	0.20	0.8	7.5	—	—	ECA1VM472	50	—	
50	2.2	5.0	11.0	20	0.12	0.5	2.0	5.0	2.5	ECA1HM2R2()	200	2000
	3.3	5.0	11.0	35	0.12	0.5	2.0	5.0	2.5	ECA1HM3R3()	200	2000
	4.7	5.0	11.0	45	0.12	0.5	2.0	5.0	2.5	ECA1HM4R7()	200	2000
	10	5.0	11.0	65	0.12	0.5	2.0	5.0	2.5	ECA1HM100()	200	2000
	22	5.0	11.0	100	0.12	0.5	2.0	5.0	2.5	ECA1HM220()	200	2000
	33	5.0	11.0	110	0.12	0.5	2.0	5.0	2.5	ECA1HM330()	200	2000
	47	6.3	11.2	130	0.12	0.5	2.5	5.0	2.5	ECA1HM470()	200	2000
	100	8.0	11.5	250	0.12	0.6	3.5	5.0	—	ECA1HM101()	200	1000
	220	10.0	12.5	400	0.12	0.6	5.0	5.0	—	ECA1HM221()	200	500
	330	10.0	16.0	500	0.12	0.6	5.0	5.0	—	ECA1HM331()	200	500
	470	10.0	20.0	650	0.12	0.6	5.0	5.0	—	ECA1HM471()	200	500
	1000	12.5	25.0	1050	0.12	0.6	5.0	5.0	—	ECA1HM102()	200	500
	2200	16.0	31.5	1300	0.14	0.8	7.5	—	—	ECA1HM222	100	—
3300	18.0	35.5	1500	0.16	0.8	7.5	—	—	ECA1HM332	50	—	
63	10	5.0	11.0	70	0.11	0.5	2.0	5.0	2.5	ECA1JM100()	200	2000
	22	5.0	11.0	105	0.11	0.5	2.0	5.0	2.5	ECA1JM220()	200	2000
	33	6.3	11.2	130	0.11	0.5	2.5	5.0	2.5	ECA1JM330()	200	2000
	47	6.3	11.2	160	0.11	0.5	2.5	5.0	2.5	ECA1JM470()	200	2000
	100	8.0	11.5	270	0.11	0.6	3.5	5.0	—	ECA1JM101()	200	1000
	220	10.0	16.0	450	0.11	0.6	5.0	5.0	—	ECA1JM221()	200	500
	330	10.0	20.0	550	0.11	0.6	5.0	5.0	—	ECA1JM331()	200	500
	470	12.5	20.0	750	0.11	0.6	5.0	5.0	—	ECA1JM471()	200	500
	1000	16.0	25.0	1100	0.11	0.8	7.5	7.5	—	ECA1JM102()	100	250
2200	18.0	35.5	1400	0.13	0.8	7.5	—	—	ECA1JM222	50	—	

*1: Ripple current (120 Hz / +85 °C)

*2: tan δ (120 Hz / +20 °C)

• When requesting taped product, please put the letter "B" or "i" between the "()".

Lead wire pitch *B=5 mm, 7.5 mm, i=2.5 mm

• Please refer to the page of "Taping dimensions".

Characteristics list

Endurance : 85 °C 2000 h

Rated voltage (V)	Capacitance (±20 %) (μF)	Case size (mm)		Specification		Lead length (mm)			Part No.	Min. Packaging Q'ty (PCS)		
		øD	L	Ripple current*1 (mA rms)	tan δ*2	Lead dia. (ød)	Lead space			Straight leads	Taping	
							Straight	Taping *B				Taping *i
100	2.2	5.0	11.0	30	0.10	0.5	2.0	5.0	2.5	ECA2AM2R2()	200	2000
	3.3	5.0	11.0	40	0.10	0.5	2.0	5.0	2.5	ECA2AM3R3()	200	2000
	4.7	5.0	11.0	50	0.10	0.5	2.0	5.0	2.5	ECA2AM4R7()	200	2000
	10	5.0	11.0	70	0.10	0.5	2.0	5.0	2.5	ECA2AM100()	200	2000
	22	6.3	11.2	115	0.10	0.5	2.5	5.0	2.5	ECA2AM220()	200	2000
	33	8.0	11.5	145	0.10	0.6	3.5	5.0	—	ECA2AM330()	200	1000
	47	8.0	11.5	180	0.10	0.6	3.5	5.0	—	ECA2AM470()	200	1000
	100	10.0	16.0	350	0.10	0.6	5.0	5.0	—	ECA2AM101()	200	500
	220	12.5	20.0	550	0.10	0.6	5.0	5.0	—	ECA2AM221()	200	500
	330	12.5	25.0	700	0.10	0.6	5.0	5.0	—	ECA2AM331()	200	500
	470	16.0	25.0	900	0.10	0.8	7.5	7.5	—	ECA2AM471()	100	250
1000	18.0	35.5	1300	0.10	0.8	7.5	—	—	ECA2AM102	50	—	
160	2.2	6.3	11.2	53	0.16	0.5	2.5	5.0	2.5	ECA2CM2R2()	200	2000
	3.3	6.3	11.2	66	0.16	0.5	2.5	5.0	2.5	ECA2CM3R3()	200	2000
	4.7	6.3	11.2	78	0.16	0.5	2.5	5.0	2.5	ECA2CM4R7()	200	2000
	10	10.0	12.5	105	0.16	0.6	5.0	5.0	—	ECA2CM100()	200	500
	22	10.0	16.0	175	0.16	0.6	5.0	5.0	—	ECA2CM220()	200	500
	33	10.0	20.0	235	0.16	0.6	5.0	5.0	—	ECA2CM330()	200	500
	47	12.5	20.0	320	0.16	0.6	5.0	5.0	—	ECA2CM470()	200	500
	100	12.5	25.0	515	0.16	0.6	5.0	5.0	—	ECA2CM101()	200	500
	220	16.0	31.5	830	0.16	0.8	7.5	—	—	ECA2CM221	100	—
	330	18.0	31.5	1090	0.16	0.8	7.5	—	—	ECA2CM331	50	—
470	18.0	40.0	1440	0.16	0.8	7.5	—	—	ECA2CM471	50	—	
200	2.2	6.3	11.2	50	0.18	0.5	2.5	5.0	2.5	ECA2DM2R2()	200	2000
	3.3	6.3	11.2	62	0.18	0.5	2.5	5.0	2.5	ECA2DM3R3()	200	2000
	4.7	8.0	11.5	86	0.18	0.6	3.5	5.0	—	ECA2DM4R7()	200	1000
	10	10.0	12.5	100	0.18	0.6	5.0	5.0	—	ECA2DM100()	200	500
	22	10.0	20.0	180	0.18	0.6	5.0	5.0	—	ECA2DM220()	200	500
	33	10.0	20.0	220	0.18	0.6	5.0	5.0	—	ECA2DM330()	200	500
	47	12.5	20.0	300	0.18	0.6	5.0	5.0	—	ECA2DM470()	200	500
	100	16.0	25.0	475	0.18	0.8	7.5	7.5	—	ECA2DM101()	100	250
	220	18.0	31.5	835	0.18	0.8	7.5	—	—	ECA2DM221	50	—
	330	18.0	40.0	1140	0.18	0.8	7.5	—	—	ECA2DM331	50	—

*1: Ripple current (120 Hz / +85 °C)

*2: tan δ (120 Hz / +20 °C)

- When requesting taped product, please put the letter "B" or "i" between the "()".
Lead wire pitch *B=5 mm, 7.5 mm, i=2.5 mm
- Please refer to the page of "Taping dimensions".

Characteristics list

Endurance : 85 °C 2000 h

Rated voltage (V)	Capacitance (±20 %) (μF)	Case size (mm)		Specification		Lead length (mm)				Part No.	Min. Packaging Q'ty (PCS)	
		øD	L	Ripple current*1 (mA rms)	tan δ*2	Lead dia. (ød)	Lead space				Straight leads	Taping
							Straight	Taping *B	Taping *i			
250	2.2	6.3	11.2	50	0.18	0.5	2.5	5.0	2.5	ECA2EM2R2()	200	2000
	3.3	8.0	11.5	72	0.18	0.6	3.5	5.0	—	ECA2EM3R3()	200	1000
	4.7	8.0	11.5	86	0.18	0.6	3.5	5.0	—	ECA2EM4R7()	200	1000
	10	10.0	16.0	110	0.18	0.6	5.0	5.0	—	ECA2EM100()	200	500
	22	10.0	20.0	180	0.18	0.6	5.0	5.0	—	ECA2EM220()	200	500
	33	12.5	20.0	250	0.18	0.6	5.0	5.0	—	ECA2EM330()	200	500
	47	12.5	25.0	330	0.18	0.6	5.0	5.0	—	ECA2EM470()	200	500
	100	16.0	31.5	530	0.18	0.8	7.5	—	—	ECA2EM101	100	—
220	18.0	40.0	930	0.18	0.8	7.5	—	—	ECA2EM221	50	—	
350	2.2	8.0	11.5	55	0.20	0.6	3.5	5.0	—	ECA2VM2R2()	200	1000
	3.3	8.0	11.5	60	0.20	0.6	3.5	5.0	—	ECA2VM3R3()	200	1000
	4.7	10.0	12.5	65	0.20	0.6	5.0	5.0	—	ECA2VM4R7()	200	500
	10	10.0	20.0	115	0.20	0.6	5.0	5.0	—	ECA2VM100()	200	500
	22	12.5	20.0	195	0.20	0.6	5.0	5.0	—	ECA2VM220()	200	500
	33	16.0	25.0	300	0.20	0.8	7.5	7.5	—	ECA2VM330()	100	250
	47	16.0	25.0	325	0.20	0.8	7.5	7.5	—	ECA2VM470()	100	250
	100	18.0	31.5	535	0.20	0.8	7.5	—	—	ECA2VM101	50	—
400	2.2	8.0	11.5	50	0.20	0.6	3.5	5.0	—	ECA2GM2R2()	200	1000
	3.3	10.0	12.5	54	0.20	0.6	5.0	5.0	—	ECA2GM3R3()	200	500
	4.7	10.0	16.0	72	0.20	0.6	5.0	5.0	—	ECA2GM4R7()	200	500
	10	10.0	20.0	115	0.20	0.6	5.0	5.0	—	ECA2GM100()	200	500
	22	12.5	25.0	215	0.20	0.6	5.0	5.0	—	ECA2GM220()	200	500
	33	16.0	25.0	275	0.20	0.8	7.5	7.5	—	ECA2GM330()	100	250
	47	16.0	31.5	350	0.20	0.8	7.5	—	—	ECA2GM470	100	—
	100	18.0	40.0	600	0.20	0.8	7.5	—	—	ECA2GM101	50	—
450	2.2	10.0	12.5	44	0.20	0.6	5.0	5.0	—	ECA2WM2R2()	200	500
	3.3	10.0	16.0	60	0.20	0.6	5.0	5.0	—	ECA2WM3R3()	200	500
	4.7	10.0	20.0	79	0.20	0.6	5.0	5.0	—	ECA2WM4R7()	200	500
	10	12.5	20.0	130	0.20	0.6	5.0	5.0	—	ECA2WM100()	200	500
	22	16.0	25.0	210	0.20	0.8	7.5	7.5	—	ECA2WM220()	100	250
	33	16.0	31.5	285	0.20	0.8	7.5	—	—	ECA2WM330	100	—

*1: Ripple current (120 Hz / +85 °C)

*2: tan δ (120 Hz / +20 °C)

• When requesting taped product, please put the letter "B" or "i" between the "()".

Lead wire pitch *B=5 mm, 7.5 mm, i=2.5 mm

• Please refer to the page of "Taping dimensions".



This Series is no longer available for purchase in the country of Japan.

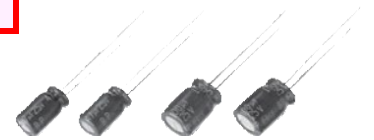

Radial Lead Type SU-A (Bi-polar) series

Features

- Endurance : 85 °C 2000 h
- RoHS compliant

Specifications

Category temp. range	-40 °C to +85 °C	
Rated voltage range	6.3 V to 50 V	
Capacitance range	2.2 μF to 6800 μF	
Capacitance tolerance	±20 % (120 Hz / +20°C)	
Leakage current	I ≤ 0.03 CV + 3 (μA) After 5 minutes	
Dissipation factor (tan δ)	Please see the attached characteristics list	
Endurance	After 2000 h application of DC working voltage (1000 h for each polarity) at +85 °C ± 2 °C, when the capacitors are restored to 20 °C, the capacitors shall meet the following limits.	
	Capacitance change	Within ±20 % of the initial value
	Dissipation factor (tan δ)	≤ 150 % of the initial limit
Shelf life	DC leakage current	Within the initial limit
	After storage for 1000 h at +85 °C ± 2 °C with no voltage applied and then being stabilized at +20 °C, capacitors shall meet the limits specified in endurance. (With voltage treatment)	

Frequency correction factor for ripple current

Freq.(Hz)	50, 60	120	1 k	10 k to
Capacitance (μF)				
2.2 to 6800	0.70	1.00	1.30	1.70

Dimensions

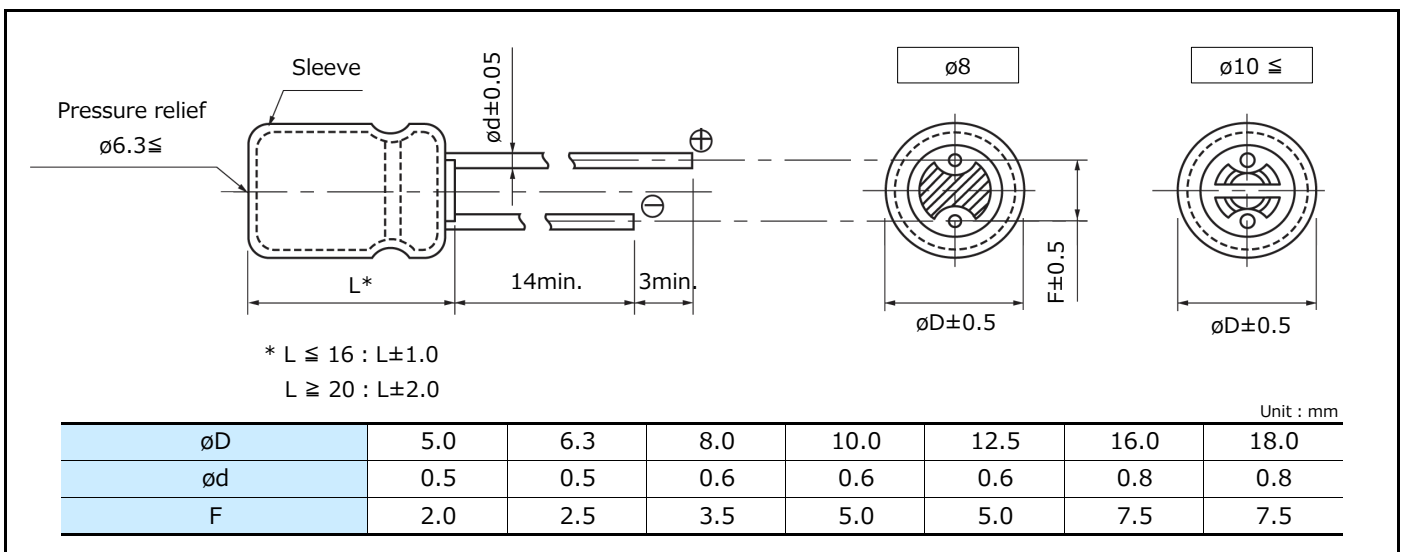

Characteristics list

Endurance : 85 °C 2000 h (1000 h for each polarity)

Rated voltage (V)	Capacitance (±20 %) (μF)	Case size (mm)		Specification		Lead length (mm)				Part No.	Min. Packaging Q'ty (PCS)	
		øD	L	Ripple current* ¹ (mA rms)	tan δ* ²	Lead dia. (ød)	Lead space				Straight leads	Taping
							Straight	Taping *B	Taping *i			
6.3	330	8.0	11.5	250	0.30	0.6	3.5	5.0	—	ECEA0JN331U()	200	1000
	470	10.0	12.5	310	0.30	0.6	5.0	5.0	—	ECEA0JN471X()	200	500
	1000	10.0	20.0	430	0.30	0.6	5.0	5.0	—	ECEA0JN102U()	200	500
	2200	12.5	25.0	660	0.32	0.6	5.0	5.0	—	ECEA0JN222U()	200	500
	3300	16.0	25.0	760	0.34	0.8	7.5	7.5	—	ECEA0JN332U()	100	250
	4700	16.0	31.5	1170	0.36	0.8	7.5	—	—	ECEA0JN472U	100	—
	6800	18.0	35.5	1450	0.40	0.8	7.5	—	—	ECEA0JN682U	50	—
10	47	5.0	11.0	90	0.25	0.5	2.0	5.0	2.5	ECEA1AN470U()	200	2000
	100	6.3	11.2	130	0.25	0.5	2.5	5.0	2.5	ECEA1AN101X()	200	2000
	220	8.0	11.5	200	0.25	0.6	3.5	5.0	—	ECEA1AN221U()	200	1000
	330	10.0	16.0	280	0.25	0.6	5.0	5.0	—	ECEA1AN331U()	200	500
	470	10.0	16.0	340	0.25	0.6	5.0	5.0	—	ECEA1AN471U()	200	500
	1000	12.5	20.0	470	0.25	0.6	5.0	5.0	—	ECEA1AN102X()	200	500
	2200	16.0	25.0	690	0.27	0.8	7.5	7.5	—	ECEA1AN222U()	100	250
	3300	16.0	31.5	1090	0.29	0.8	7.5	—	—	ECEA1AN332U	100	—
4700	18.0	35.5	1200	0.31	0.8	7.5	—	—	ECEA1AN472U	50	—	
16	10	5.0	11.0	40	0.20	0.5	2.0	5.0	2.5	ECEA1CN100U()	200	2000
	22	5.0	11.0	60	0.20	0.5	2.0	5.0	2.5	ECEA1CN220U()	200	2000
	33	5.0	11.0	80	0.20	0.5	2.0	5.0	2.5	ECEA1CN330U()	200	2000
	47	6.3	11.2	100	0.20	0.5	2.5	5.0	2.5	ECEA1CN470U()	200	2000
	220	10.0	12.5	260	0.20	0.6	5.0	5.0	—	ECEA1CN221X()	200	500
	330	10.0	16.0	330	0.20	0.6	5.0	5.0	—	ECEA1CN331U()	200	500
	470	10.0	20.0	380	0.20	0.6	5.0	5.0	—	ECEA1CN471U()	200	500
	1000	12.5	25.0	560	0.20	0.6	5.0	5.0	—	ECEA1CN102U()	200	500
	2200	16.0	31.5	750	0.22	0.8	7.5	—	—	ECEA1CN222U	100	—
3300	18.0	35.5	900	0.24	0.8	7.5	—	—	ECEA1CN332U	50	—	
25	10	5.0	11.0	45	0.15	0.5	2.0	5.0	2.5	ECEA1EN100U()	200	2000
	22	5.0	11.0	60	0.15	0.5	2.0	5.0	2.5	ECEA1EN220X()	200	2000
	33	6.3	11.2	90	0.15	0.5	2.5	5.0	2.5	ECEA1EN330U()	200	2000
	47	6.3	11.2	110	0.15	0.5	2.5	5.0	2.5	ECEA1EN470U()	200	2000
	100	8.0	11.5	180	0.15	0.6	3.5	5.0	—	ECEA1EN101U()	200	1000
	220	10.0	16.0	320	0.15	0.6	5.0	5.0	—	ECEA1EN221U()	200	500
	330	12.5	20.0	350	0.15	0.6	5.0	5.0	—	ECEA1EN331U()	200	500
	470	12.5	20.0	430	0.15	0.6	5.0	5.0	—	ECEA1EN471U()	200	500
	1000	16.0	25.0	680	0.15	0.8	7.5	7.5	—	ECEA1EN102U()	100	250
	2200	18.0	35.5	900	0.17	0.8	7.5	—	—	ECEA1EN222U	50	—
35	10	5.0	11.0	43	0.15	0.5	2.0	5.0	2.5	ECEA1VN100U()	200	2000
	22	6.3	11.2	80	0.15	0.5	2.5	5.0	2.5	ECEA1VN220U()	200	2000
	33	8.0	11.5	100	0.15	0.6	3.5	5.0	—	ECEA1VN330U()	200	1000
	47	8.0	11.5	120	0.15	0.6	3.5	5.0	—	ECEA1VN470U()	200	1000
	100	10.0	16.0	230	0.15	0.6	5.0	5.0	—	ECEA1VN101U()	200	500
	220	12.5	20.0	360	0.15	0.6	5.0	5.0	—	ECEA1VN221U()	200	500
	330	12.5	20.0	450	0.15	0.6	5.0	5.0	—	ECEA1VN331U()	200	500
	470	12.5	25.0	590	0.15	0.6	5.0	5.0	—	ECEA1VN471U()	200	500

*1: Ripple current (120 Hz / +85 °C)

*2: tan δ (120 Hz / +20 °C)

- When requesting taped product, please put the letter "B" or "i" between the "()".
Lead wire pitch *B=5 mm, 7.5 mm, i=2.5 mm.
- Please refer to the page of "Taping dimensions".

Characteristics list

Endurance : 85 °C 2000 h (1000 h for each polarity)

Rated voltage (V)	Capacitance (±20 %) (μF)	Case size (mm)		Specification		Lead length (mm)			Part No.	Min. Packaging Q'ty (PCS)		
		øD	L	Ripple current* ¹ (mA rms)	tan δ* ²	Lead dia. (ød)	Lead space			Strai-ght leads	Taping	
							Straight	Taping *B				Taping *i
50	2.2	5.0	11.0	18	0.15	0.5	2.0	5.0	2.5	ECEA1HN2R2U()	200	2000
	3.3	5.0	11.0	25	0.15	0.5	2.0	5.0	2.5	ECEA1HN3R3U()	200	2000
	4.7	5.0	11.0	30	0.15	0.5	2.0	5.0	2.5	ECEA1HN4R7U()	200	2000
	10	6.3	11.2	50	0.15	0.5	2.5	5.0	2.5	ECEA1HN100U()	200	2000
	22	8.0	11.5	90	0.15	0.6	3.5	5.0	—	ECEA1HN220U()	200	1000
	33	8.0	11.5	110	0.15	0.6	3.5	5.0	—	ECEA1HN330U()	200	1000
	47	10.0	12.5	140	0.15	0.6	5.0	5.0	—	ECEA1HN470U()	200	500
	100	10.0	20.0	250	0.15	0.6	5.0	5.0	—	ECEA1HN101U()	200	500
	220	12.5	25.0	360	0.15	0.6	5.0	5.0	—	ECEA1HN221U()	200	500
	330	16.0	25.0	450	0.15	0.8	7.5	7.5	—	ECEA1HN331U()	100	250
470	16.0	31.5	590	0.15	0.8	7.5	—	—	ECEA1HN471U	100	—	

*1: Ripple current (120 Hz / +85 °C)

*2: tan δ (120 Hz / +20 °C)

- When requesting taped product, please put the letter "B" or "i" between the "()".
Lead wire pitch *B=5 mm, 7.5 mm, i=2.5 mm.
- Please refer to the page of "Taping dimensions".

CAUTION AND WARNING

1. The electronic components contained in this catalog are designed and produced for use in home electric appliances, office equipment, information equipment, communications equipment, and other general purpose electronic devices. Before use of any of these components for equipment that requires a high degree of safety, such as medical instruments, aerospace equipment, disaster-prevention equipment, security equipment, vehicles (automobile, train, vessel), please be sure to contact our sales representative corporation.
2. When applying one of these components for equipment requiring a high degree of safety, no matter what sort of application it might be, be sure to install a protective circuit or redundancy arrangement to enhance the safety of your equipment. In addition, please carry out the safety test on your own responsibility.
3. When using our products, no matter what sort of equipment they might be used for, be sure to make a written agreement on the specifications with us in advance.
4. Technical information contained in this catalog is intended to convey examples of typical performances and or applications and is not intended to make any warranty with respect to the intellectual property rights or any other related rights of our company or any third parties nor grant any license under such rights.
5. In order to export products in this catalog, the exporter may be subject to the export license requirement under the Foreign Exchange and Foreign Trade Law of Japan.
6. No ozone-depleting substances (ODSs) under the Montreal Protocol are used in the manufacturing processes of Automotive & Industrial Systems Company, Panasonic Corporation.

● Please contact

● Factory

Device Solutions Business Division
Industrial Solutions Company

Panasonic[®]

1006 Kadoma, Kadoma City, Osaka 571-8506,
JAPAN

The information in this catalog is valid as of March 2020.